

ergotron®

CareFit Pro Monitor Cart with Drawers, Powered



Includes
Constant Force™
Technology

CareFit powered carts provide electrical AC power for mobile point of care computing equipment in a healthcare environment. The carts are not intended to power medical products or devices. Outlets are provided to power information technology equipment only such as computer equipment and computer peripherals.

English



For the latest User Installation Guide please visit: www.ergotron.com

English, Español, Français, Deutsch, Nederlands, Italiano, Svenska, 日本語, 汉语

www.ergotron.com | USA: 1-800-888-8458 | Europe: +31 (0)33-45 45 600 | China: 400-120-3051 | Japan: japansupport@ergotron.com

Table of Contents

Getting to Know Your CareFit.....	3
Set-up.....	4-10
Adjustment.....	9-10
Touch Screen Control Panel / Battery Status.....	12
eKinnex™	13
Ergonomics.....	14
Optional Attachments and Features	15-19
Change Batteries.....	20
Cart Storage	21
Specifications	21-23
Safety	24-27
Cleaning and Maintenance.....	27

Getting to Know Your CareFit

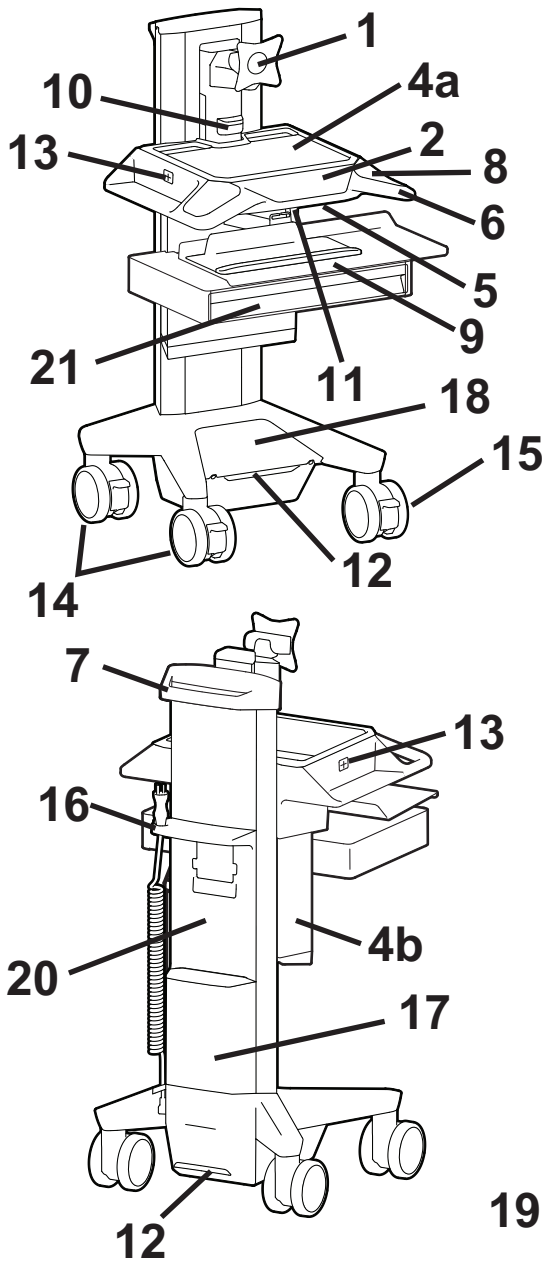

1. LCD Mount for LCDs or Tablet PC's with 75x75 or 100x100mm Mounting Interface and Provides Extension, Tilt, Pan, and P/L Rotation
2. Touch Screen Control Panel Controls all Lights, Power System on/off, Displays Battery Charge Levels, and provides Low Battery Charge warning
3. Badge Scanning location for customer supplied RFID
4. a. Secure Storage for CPU, Cable Management, Excess Cables, Provided Hex Wrench holder, Seven Port USB Hub, and Removable Top/Worksurface
b. Side Access Door to Four Power Cord Receptacles
5. Worksurface Lock and Release
6. Two Front Handles
7. Rear Handle
8. Height Adjustment Brake Buttons
9. Keyboard Tray and Wrist Rest, Slides Out, Tilts, Pans and Allows for Right or Left Mousing
10. Worksurface Light
11. Three Keyboard Lights
12. Front and Rear Floor Lights
13. Two Side Cable Access Holes
14. Four Locking Casters
15. A Three Function Caster - Locks Swivel or Rotation and Swivel.
16. Power Cord and Hook
17. AC Power System and battery charger for external battery (sold separately) integrated in the base
18. Internal Battery
19. Optional Attachments: Scanner Shelf, Worksurface Document Cover, Rear Mounted Document Cover
20. External Battery Docking location or Accessory Bin Location (ordered separately)
21. Auto-Lock Drawer

15 3 Function Caster

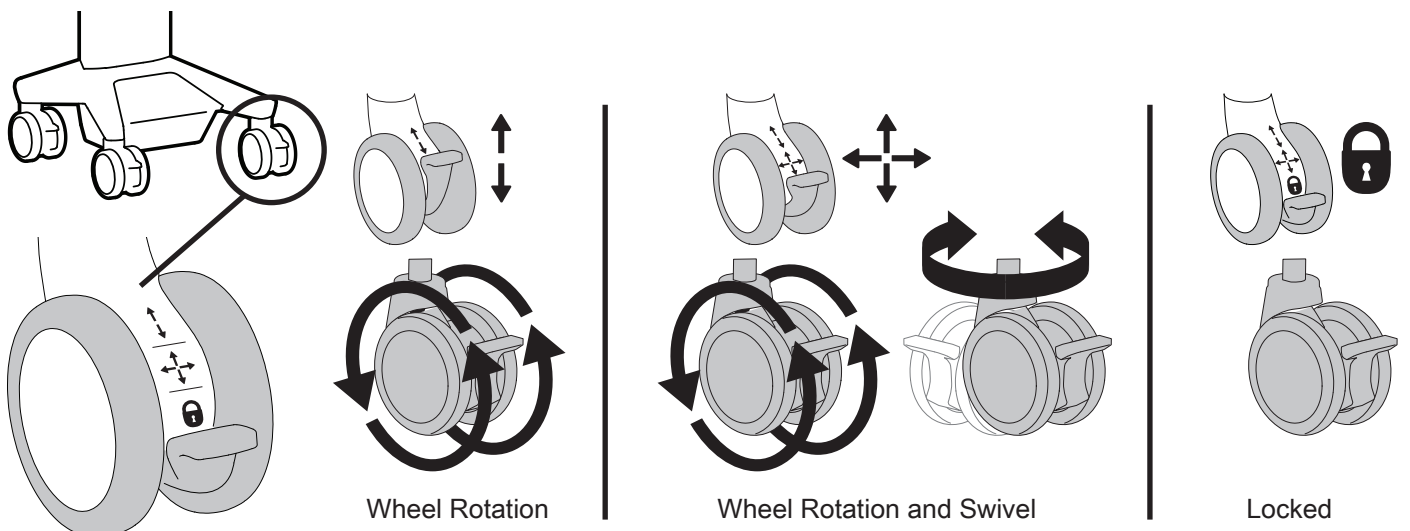

Set-up



Components

	A	B	C	D
1	1x	3x	1x	1x
2	6x 4x	1x	1x	1x
3			5x	6x
4			1x	4x
5	1x	1x	2x 2x	2x 6x



Tools Needed



Plug cart into power outlet to charge to 100% before use. Cart does not charge when turned off.

Do Not stretch coiled cord further than 6 feet (1.8 meters), damage to the cord may occur.

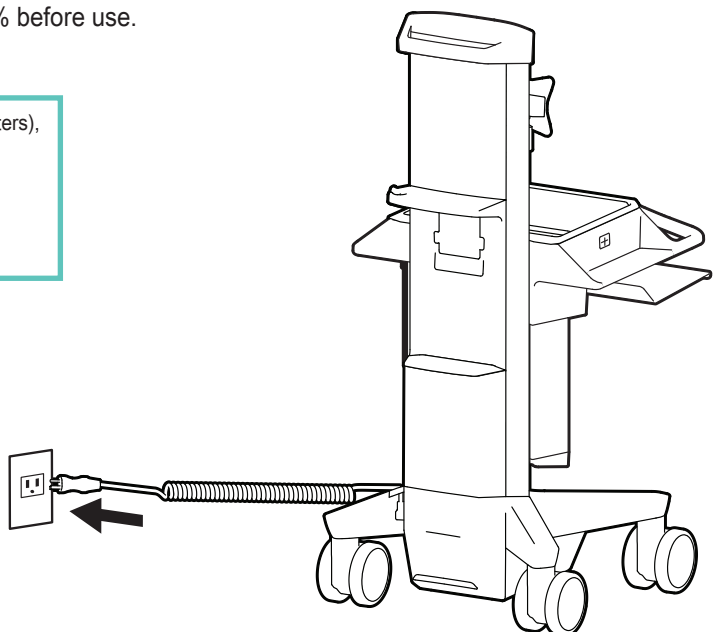
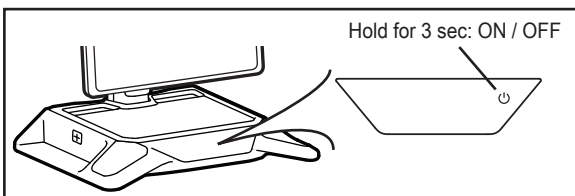
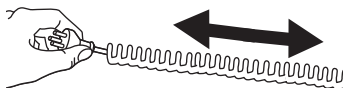

Set-up

2

1

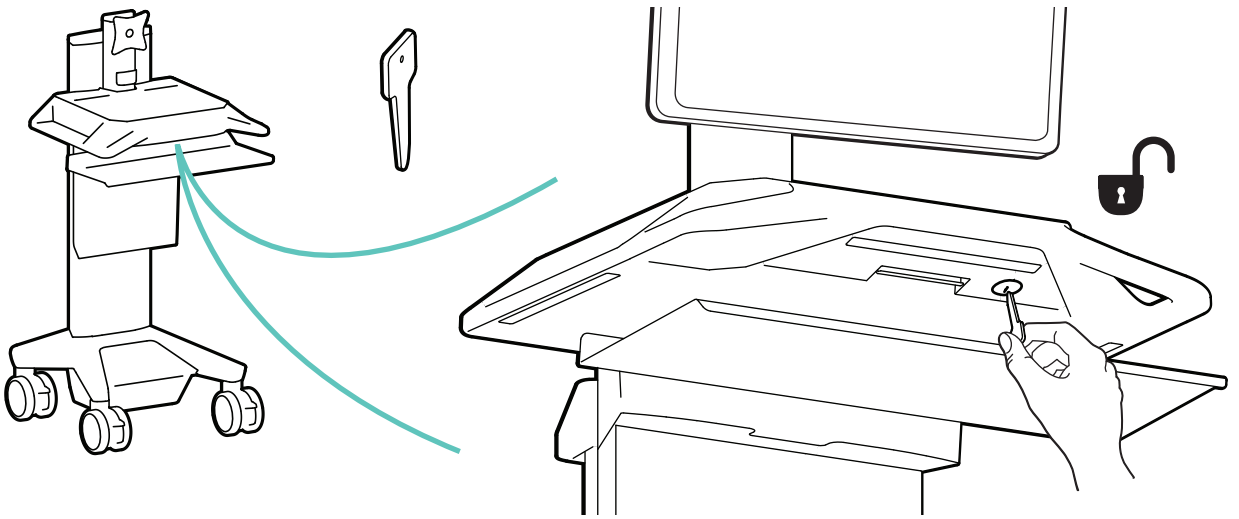

2

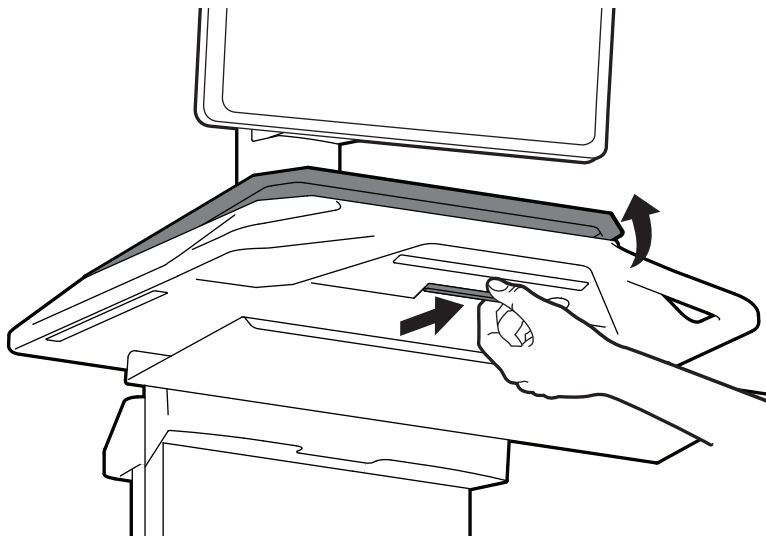

3

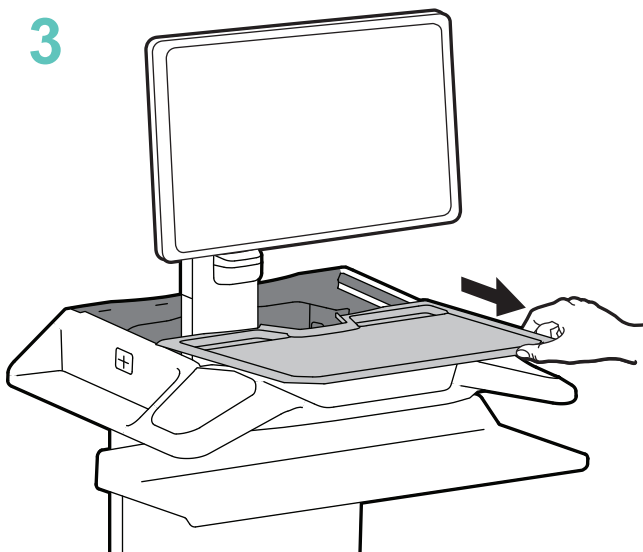

DO NOT lift up on worksurface.



Set-up

3

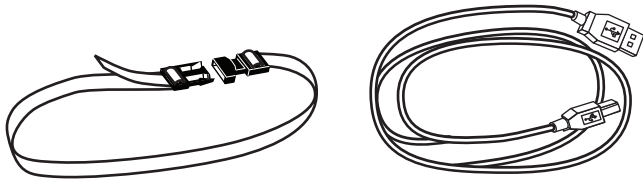

DO NOT OBSTRUCT AIR VENTS!
Obstructing air vents may cause overheating and result in equipment damage.

1

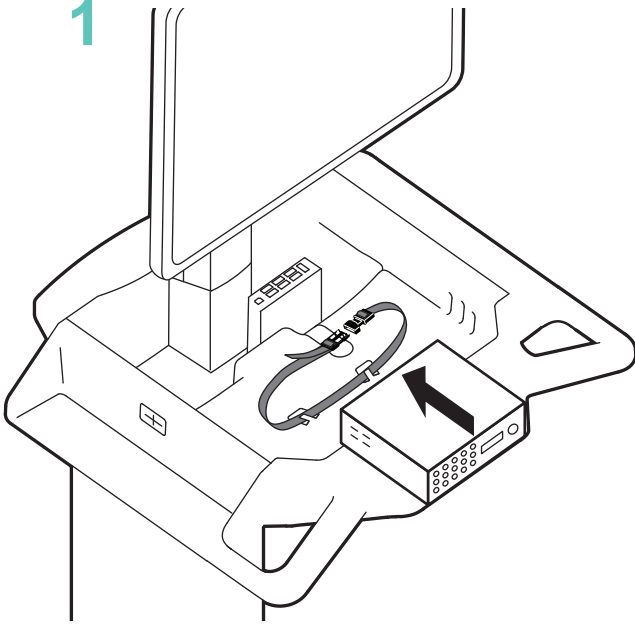

2

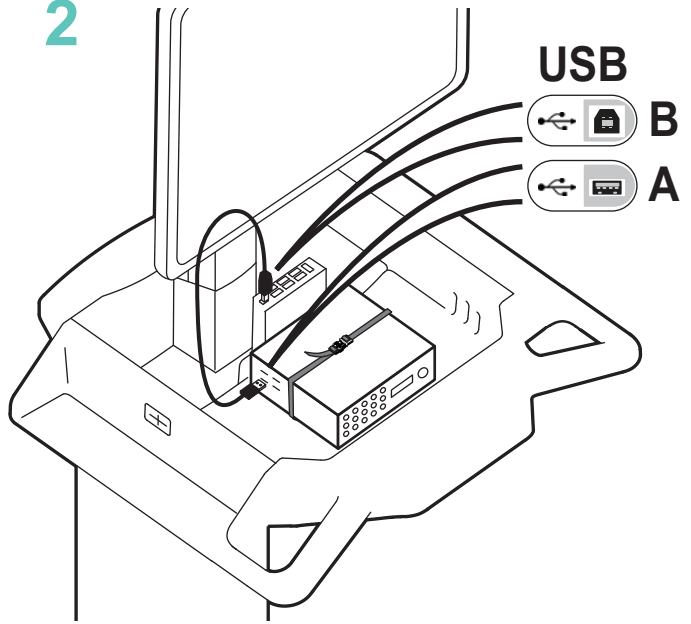

4

75x75mm / 100x100mm

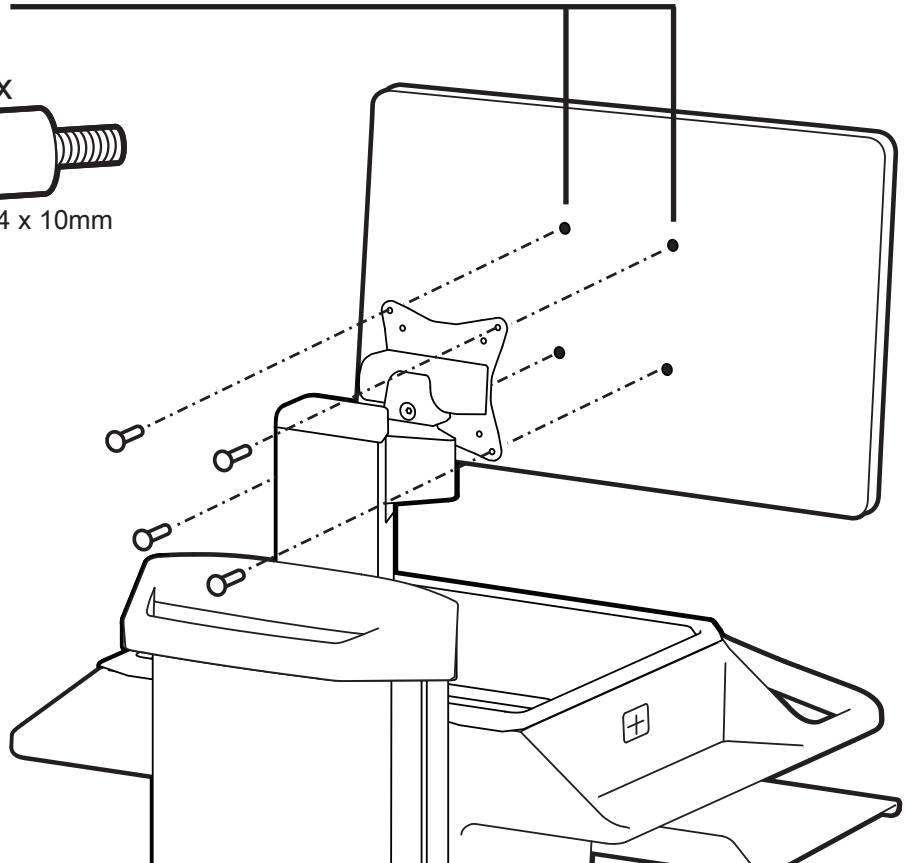
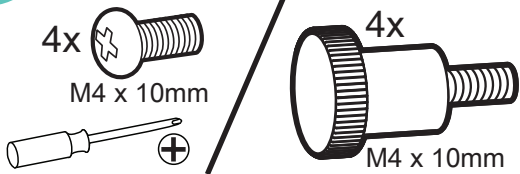

Set-up

5

1

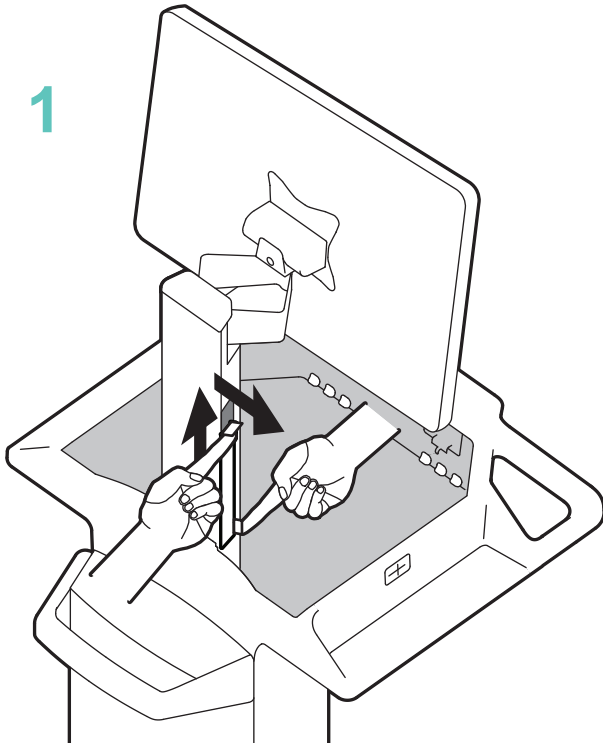

2

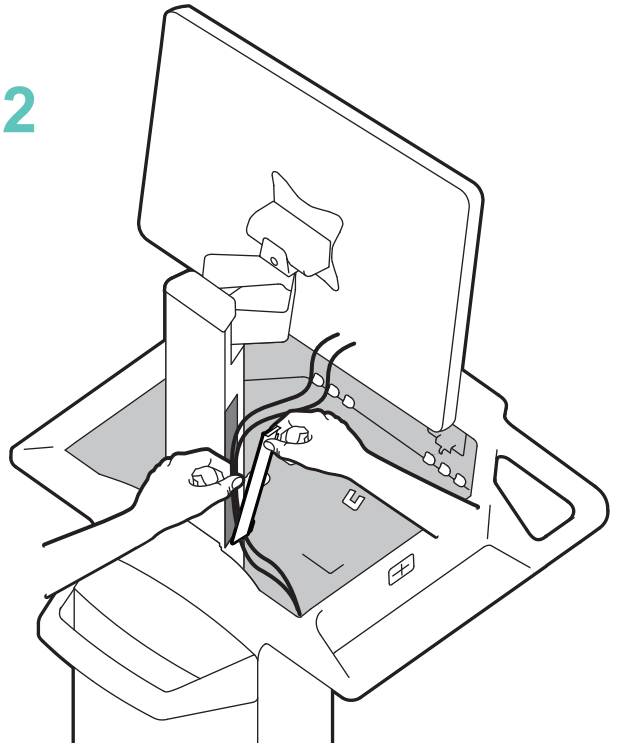

3

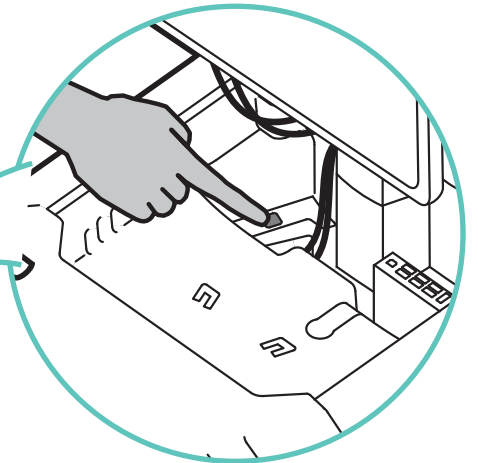
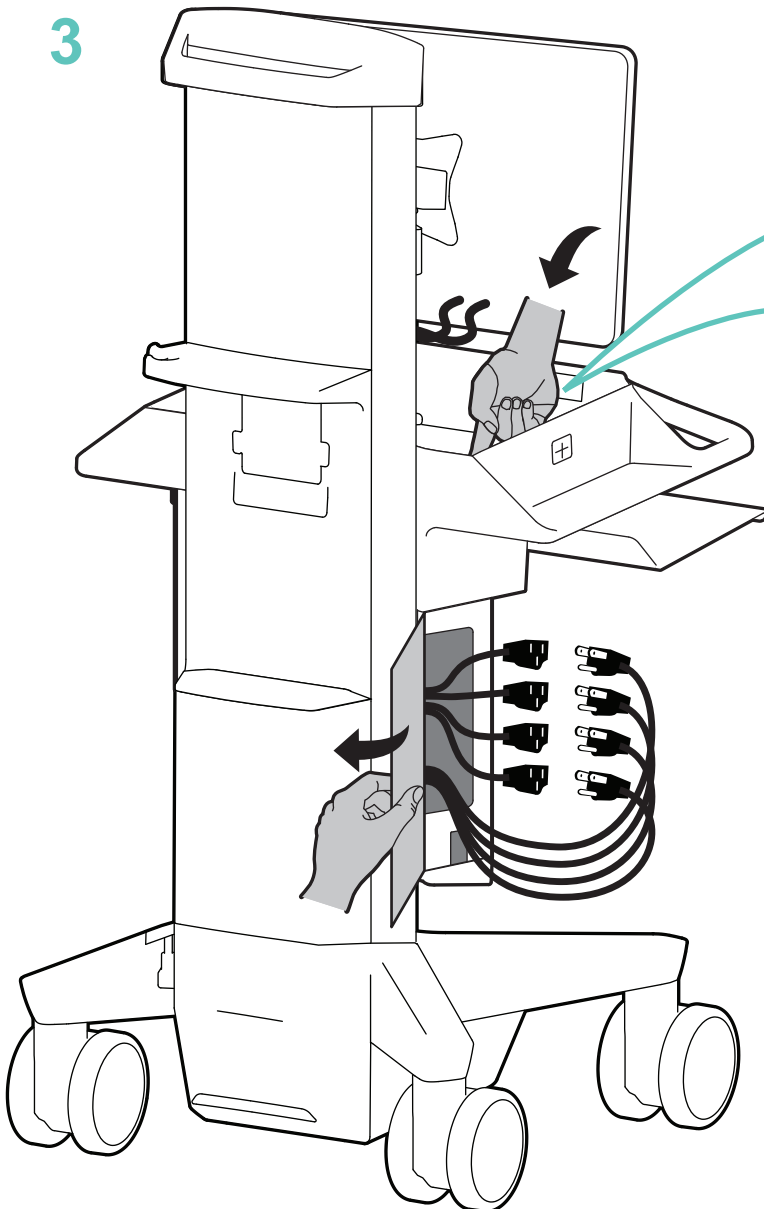

Push button to open cable compartment door.

Not all bricks and cables may fit in the IT box. Some may need to be stored in the headunit. Do not overstuff and block airflow.

Set-up

6

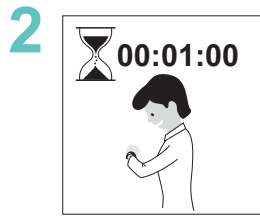
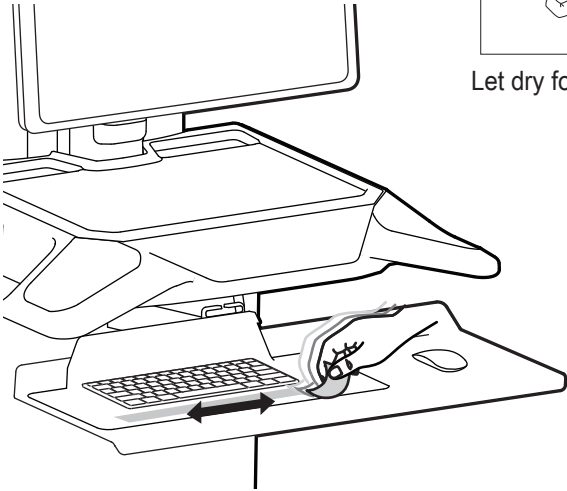

Let dry for 60 seconds.

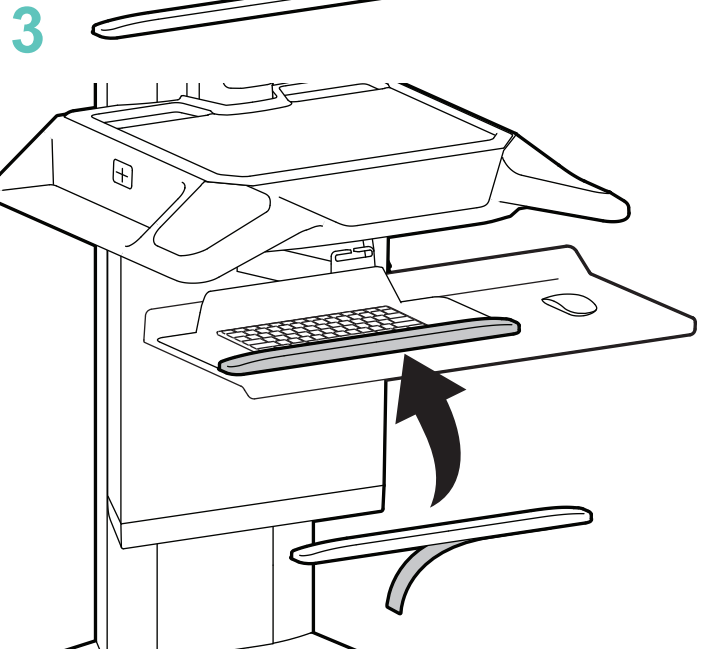

7

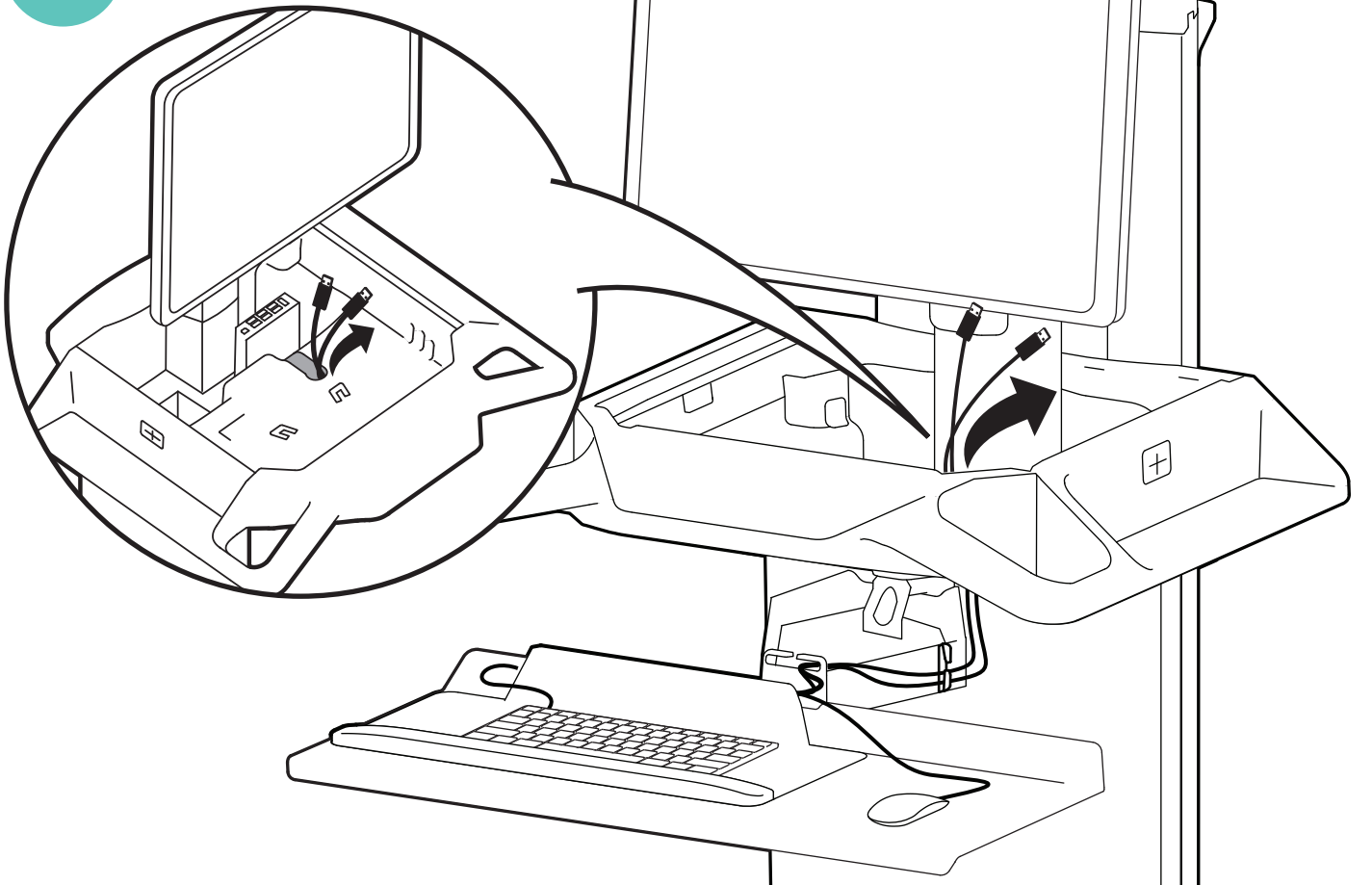

Set-up

8

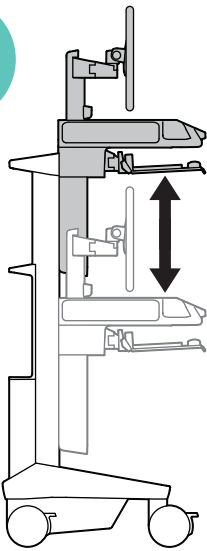

1. Turn cart on.

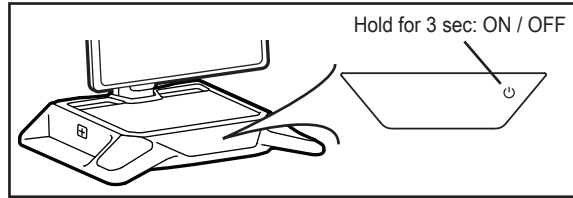

2. Push and hold one of the brake release buttons and lift cart up or down.

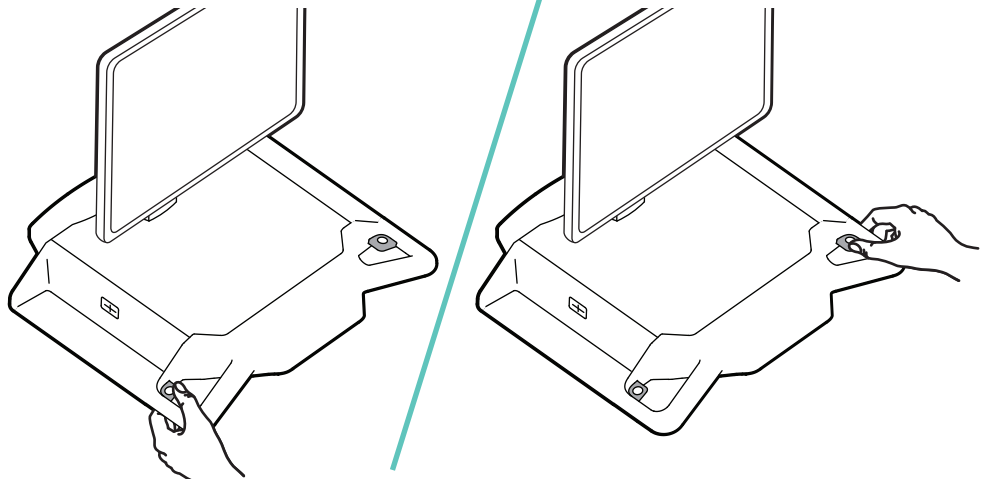

9



Adjustment Step

Important! You will need to adjust this product after installation is complete. Make sure all your equipment is properly installed on the product before attempting adjustments. This product should move smoothly and easily through the full range of motion and stay where you set it. If movements are too easy or difficult or if product does not stay in desired positions, follow the adjustment instructions to create smooth and easy movements. Depending on your product and the adjustment, it may take many turns to notice a difference. Any time equipment is added or removed from this product, resulting in a change in the weight of the mounted load, you should repeat these adjustment steps to ensure safe and optimum operation.

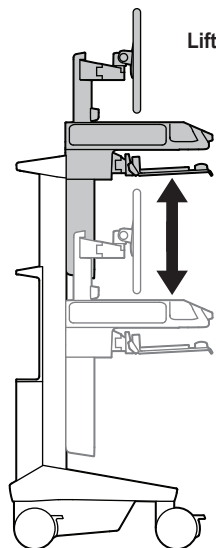

Lift – Up and down

1

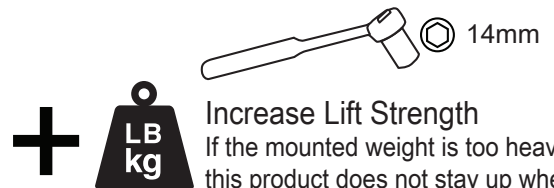
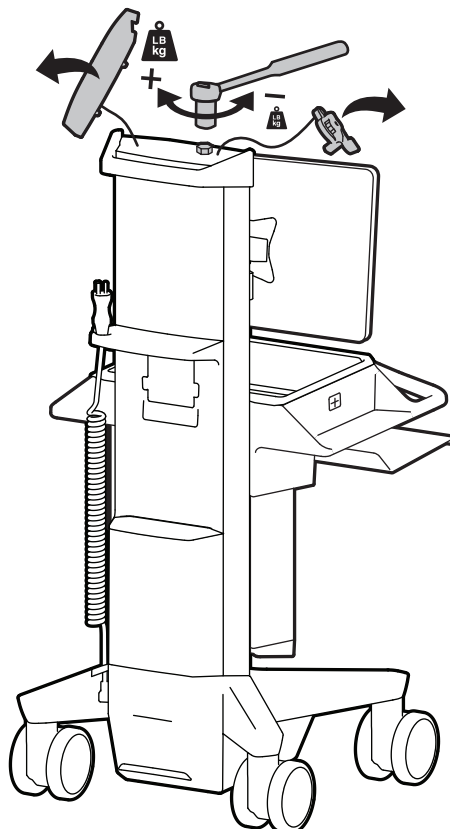

Increase Lift Strength

If the mounted weight is too heavy or this product does not stay up when raised, then you'll need to increase Lift Strength:



Decrease Lift Strength

If the mounted weight is too light or this product does not stay down when lowered, then you'll need to decrease Lift Strength:

2

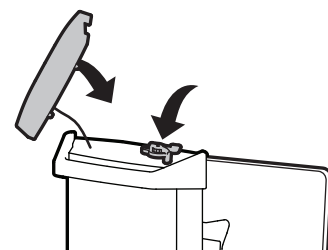

Set-up

10



Adjustment Step

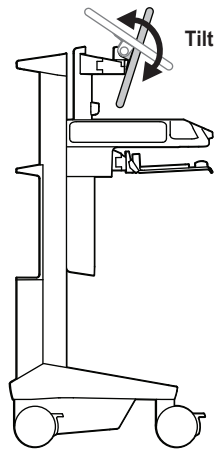

Tilt – Forward and Backward

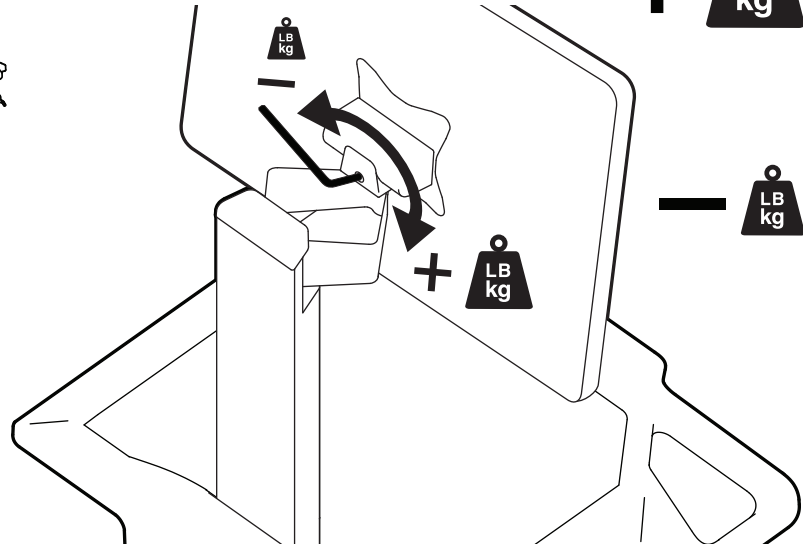

+ LB kg

Increase Lift Strength

If the mounted weight is too heavy or this product does not stay up when raised, then you'll need to increase Lift Strength:

- LB kg

Decrease Lift Strength

If the mounted weight is too light or this product does not stay down when lowered, then you'll need to decrease Lift Strength:

11



Adjustment Step



Heavy Monitor Setting
9-14 lbs (4.1-6.4 kg)



Light Weight Monitor Setting
5-9 lbs (2.2-4.1 kg)

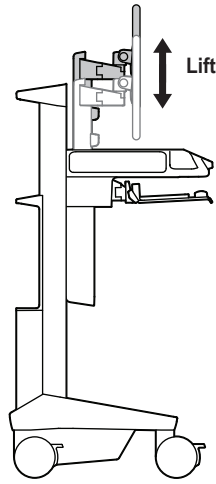

Lift – Up and down



1



2

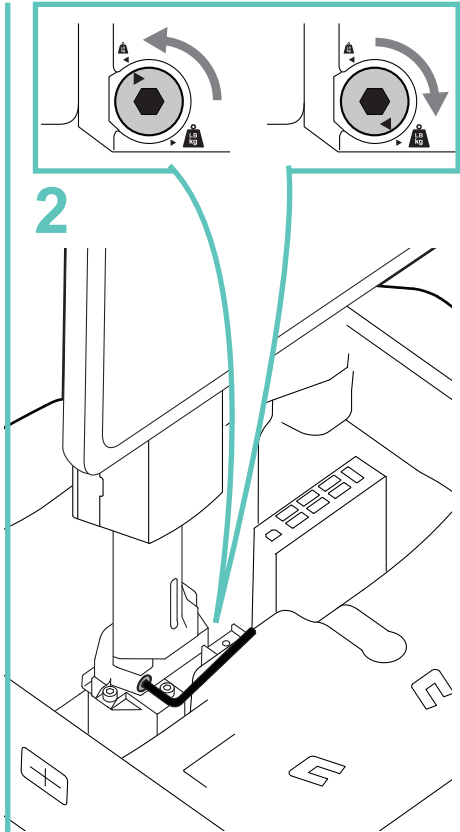

3

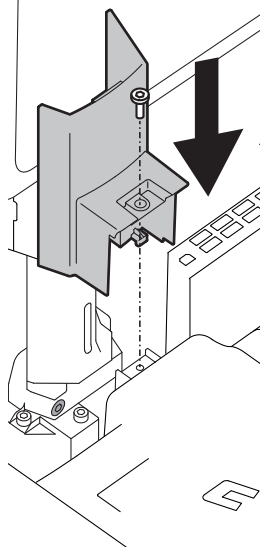

For monitors weighing 14-20 lbs (6.35-9.1 kg) see Monitor Lift Lock procedure on page 18.

Set-up

12

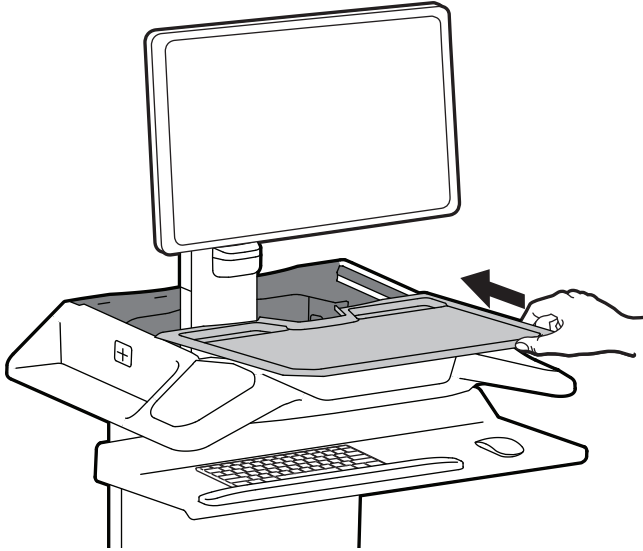
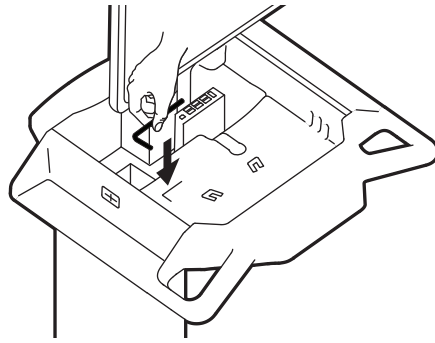

Set up is complete.

Now your Cart is ready for however you work best.



Important Information.



Touch Screen Control Panel

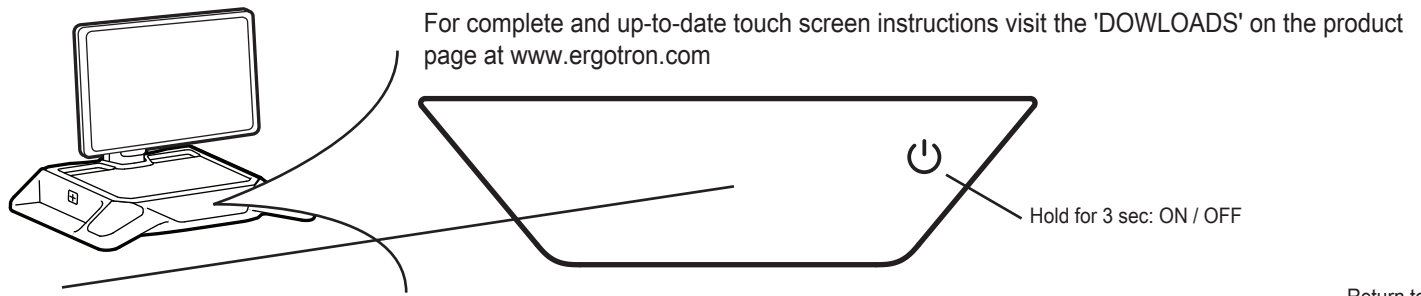

HOME SCREEN

Wi-Fi status

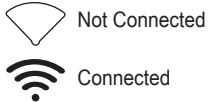

Battery Charge Level

Clock

Time remaining on battery.

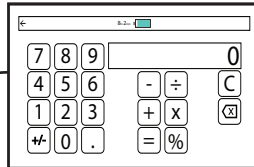

Settings

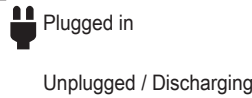
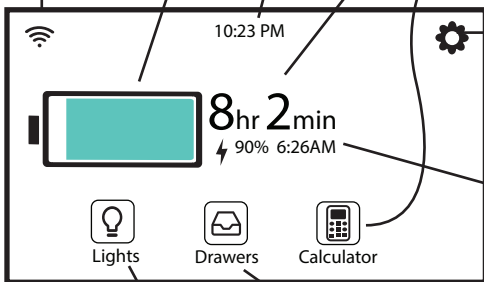
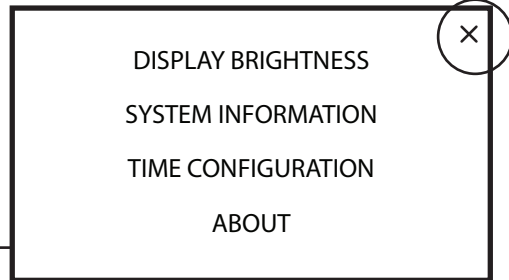

Percent of battery charge and the time the battery will be fully discharged.
Note: Carts do not charge when turned off. To Charge cart, plug in and cart will turn itself on and charge.

Return to Home Screen

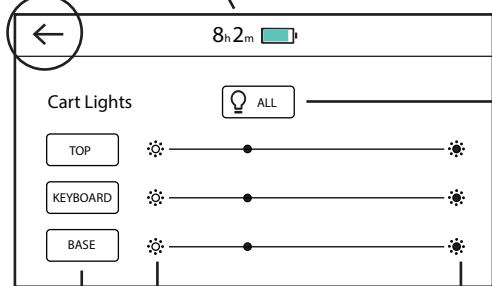

Turns lights on/off

Turns all lights on/off

Return to Home Screen

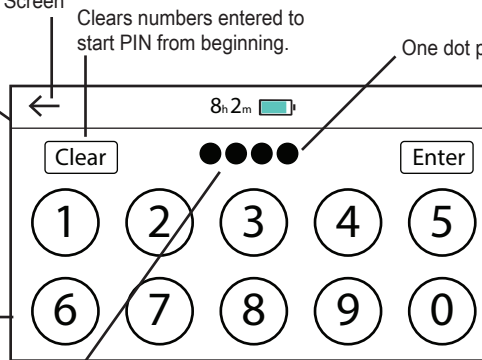

Clears numbers entered to start PIN from beginning.

One dot per PIN number entered.

Touch Enter after all PIN numbers have been entered.

Numbers for Entering PIN to open drawers. 10 seconds allowed to enter pin.



If this icon shown, drawers can be accessed using Imprivata single sign on. Cart needs to be connected to a computer running Ergotron CareFit Pro Imprivata Agent. This connection is via USB cable between the computer and the cart's USB ports.

Return to PIN entry screen, all drawers will lock.

Time to unlock drawers. All drawers will lock at 00:00.

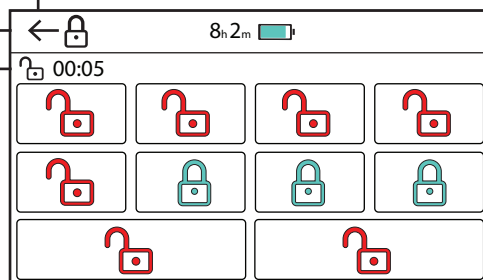

Drawer status.

DEFAULT PIN to open drawers is 1-2-3-4-5-6
DEFAULT Admin PIN is 7-6-5-4-3-2-1
Default PINs will be overwritten when connected to eKinnex. Visit the eKinnex website at www.ekinex.com to program preferences for:
- Drawer authentication timer
- Drawer open alarm – timer and audible alarm capability
- Drawer lock and unlock modes



Drawer is UNLOCKED or Open. Press to lock. When flashing, drawer has been open longer than allowed time and a buzzer will sound (if enabled in eKinnex). Press to mute buzzer.



Drawer is LOCKED or Closed. Press to unlock.

Our Wi-Fi-enabled carts use eKinnex technology allowing you to proactively monitor the status of your fleet from an online portal. Alerts ranging from low battery to battery replacement and more, help you minimize downtime while reducing IT workload. Optional service programs allow Ergotron to monitor your fleet for you and provide enhanced service response.

To connect to eKinnex, please contact Ergotron directly at:

ekinnextsupport@ergotron.com

Phone: 844-243-6244

1181 Trapp Road, Eagan, MN 55121 USA

Note:

- Each facility requires a unique email address for each unique login
- Logins cannot be shared across facilities
- Enterprise views, where one can monitor multiple facilities with one login are currently not supported

To register a device with eKinnex for CareFit:

1. Please go to www.ergotron.com/ekinnext for more information, installation downloads and contact Ergotron for initial setup.
2. If you have not received your login or your facility has not been setup in the system, please contact Ergotron by email at: ekinnextsupport@ergotron.com or by phone at 844-243-6244
3. Once your hospital has been setup in eKinnex, Ergotron will send your initial login and password
4. Please login to: CareFit.eKinnex.com and change your password
5. On the main dashboard, validate that your facility is set up correctly under Groups. If it is not, please contact Ergotron to get this corrected
6. Download the Ergotron CareFit Pro Commissioning Tool from www.ergotron.com/ekinnext and install it on a Windows computer
7. Power On the CareFit Pro cart, connect the Windows computer to the cart's USB hub in the secure storage area of the cart
8. Open the Ergotron CareFit Pro Commissioning tool, select the desired network in the GUI
9. Enter the credentials and set them via the application
10. Wait until the Wi-Fi indicator becomes present in the upper left corner of the cart's touchscreen display to validate that the cart is communicating over Wi-Fi
 - a. Allow approximately 10 minutes for the cart to check for updates. If one is available, it will download in the background
 - b. Tap the Settings icon in the upper right-hand corner of the cart's touchscreen display
 - c. Tap System Information
 - d. If an update is available, an Update button will be visible on the screen. Tap it if present
 - e. The cart will reboot with the latest version
11. Copy the association code from the Wi-Fi commissioning tool
12. In CareFit/eKinnex.com navigate to the Carts tab/Add device and paste the association code into the matching box
13. Fill in the assigned location/WAP, Service and In-Operation Alerts boxes and save
14. When cart has been commissioned with new Wi-Fi credentials, power cycle the cart by turning OFF then ON. This is only needed the first time the cart is commissioned.

CAUTION: Connection to IT Networks including other equipment could result in previously unidentified risks to patients, operators, or third parties. The responsible organization should identify, analyze, evaluate, and control these risks.

CAUTION: Change to the IT Network could introduce new risks that require additional analysis. These changes include changes in the network configuration, connection or additional items, disconnection of items, update of equipment, or upgrade of equipment.

Ergonomics

Learn more about ergonomic computer use at: www.ergotron.com/ergonomics

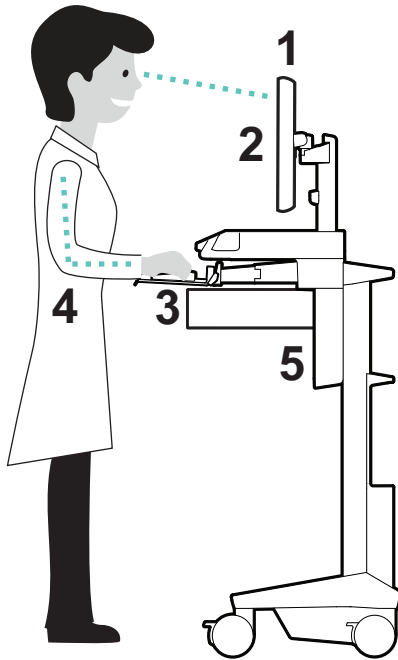
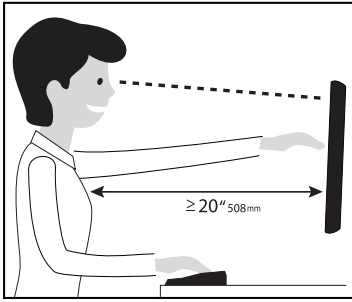

Working
customize - to your size

- 1 Set top of monitor screen about one inch below eye level - Release brake and lift or lower riser as needed.
- 2 Tilt screen for comfortable viewing and to reduce eye and neck strain.
- 3 Pull keyboard tray forward and position mouse tray on right or left, as needed.
- 4 Work with elbows bent at about 90° to minimize muscle strain.
- 5 If the riser moves up and down with difficulty, or if it drifts out of set position, consult the product manual for adjustment information.

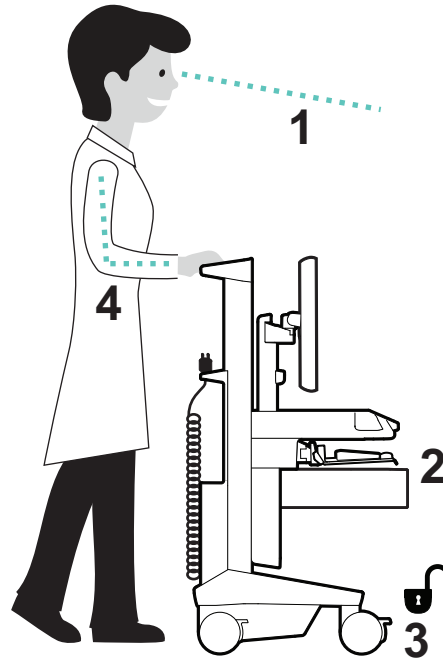





Moving
stow - before you go

- 1 During normal movement, release brake and lower worksurface to lowest position for optimal stability and unobstructed view.
- 2 Tuck away open trays and return mouse, scanner and other accessories to their places.
- 3 Unlock both front casters.
- 4 Push cart from rear with elbows bent at about 90° to maximize control and minimize muscle strain.

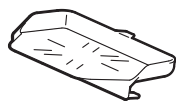
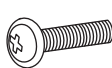
Optional Attachments and Features

Scanner Shelf

- 1x 
- 2x  M3 x 12mm
- 2x 
- 2x 
- 4x  M4 x 7mm

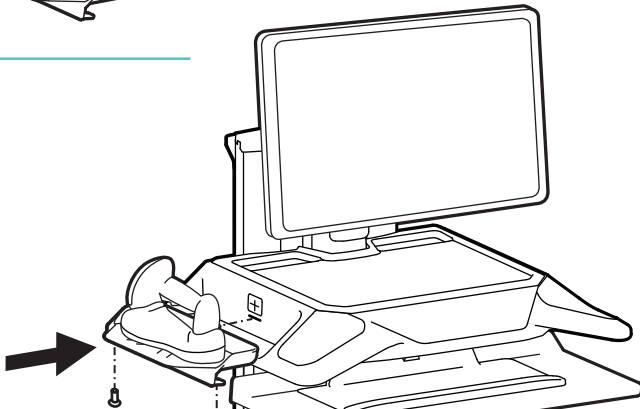
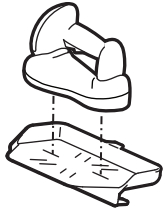

- 2x  M4 x 7mm

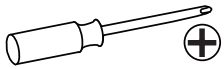

Cable Entrance/Exit

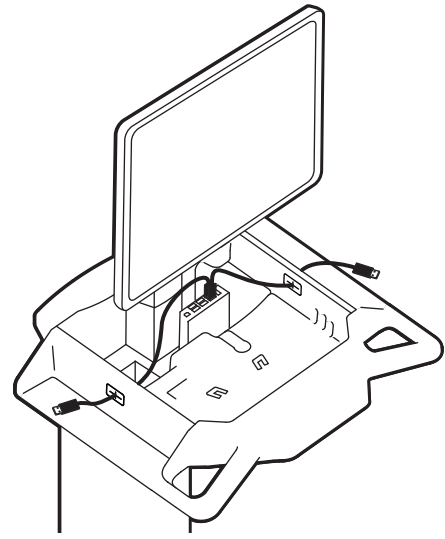

Document Holder/ Prep Surface

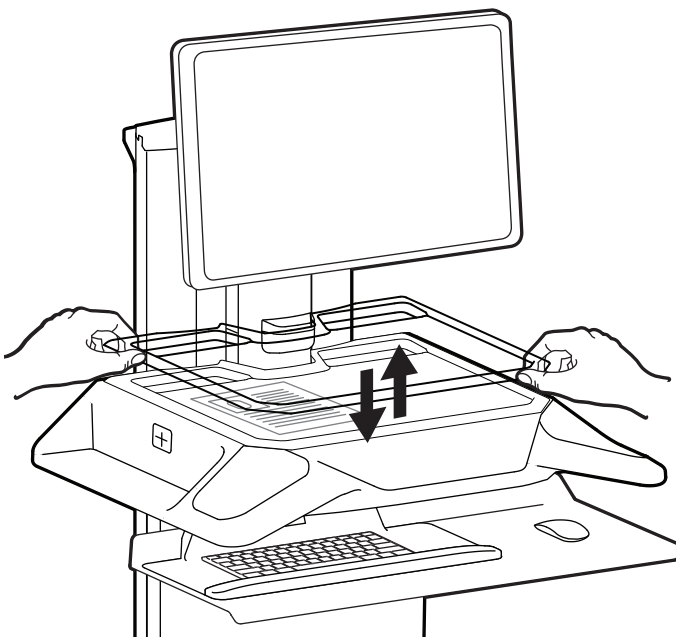

Document Holder, Rear Column

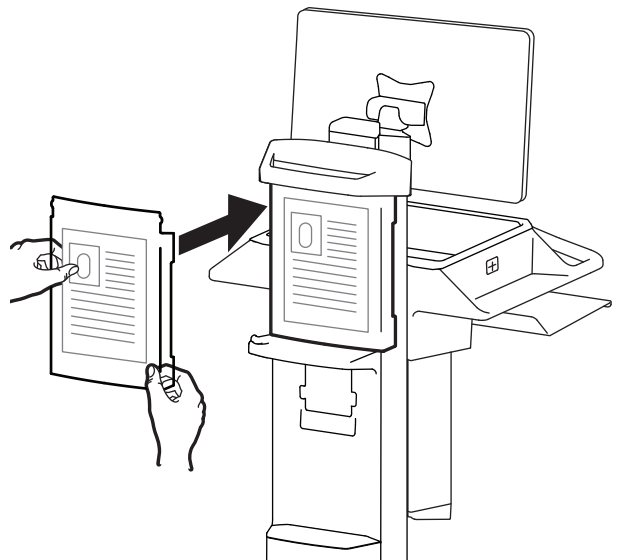

Optional Attachments and Features

Location for customer supplied RFID badge scanning access.

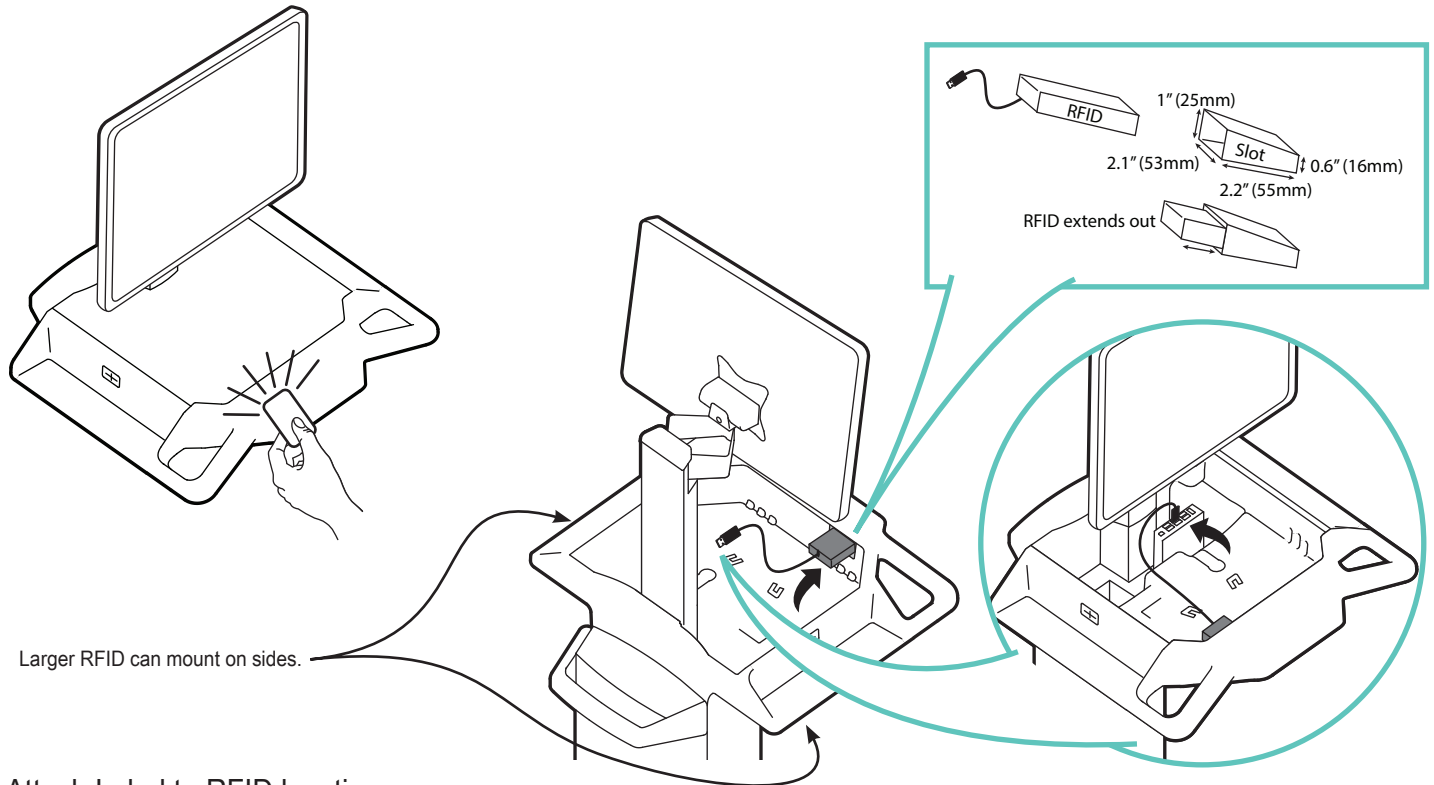

Attach Label to RFID location

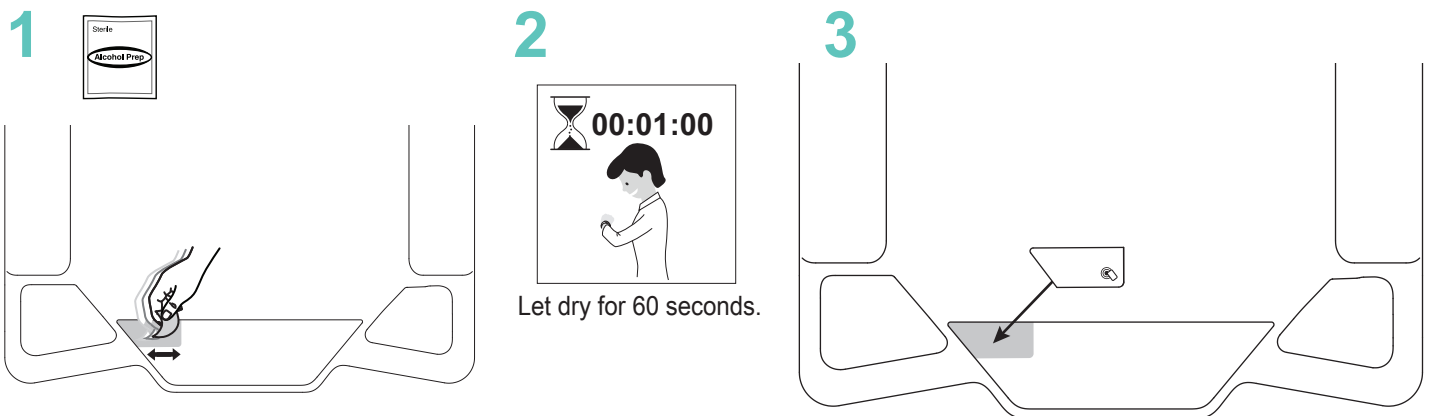

Remove cover before attaching external LiFeKinnex™ battery (sold separately).

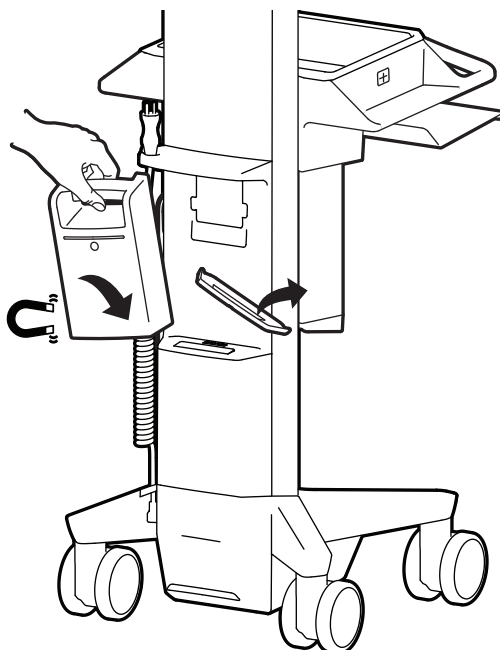

Save cover for reuse when battery is not being used.



WARNING: Battery contains magnets. Magnets may be harmful to persons with implanted medical devices. Keep battery at least 6" (152 mm) away from any implanted medical devices.

Optional Attachments and Features

5x

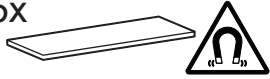

Magnetic Tape

1

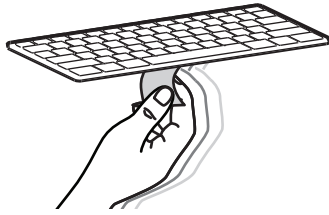

2



Let dry for 60 seconds.

3

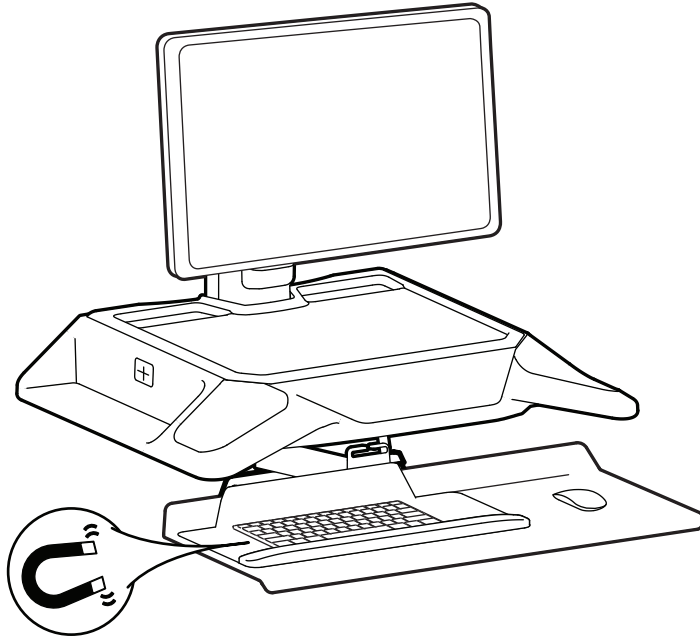
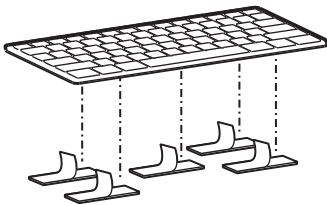

Adhesive Pads

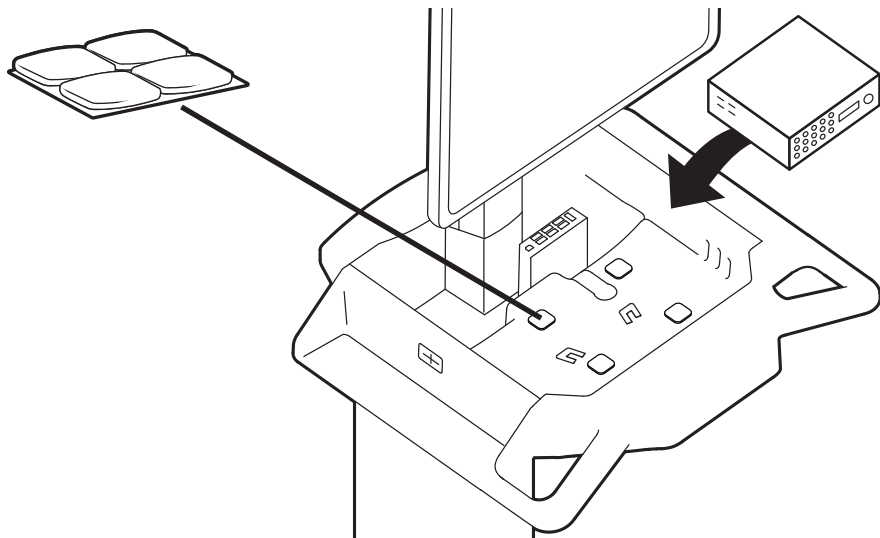

Cable Management



6x

4x

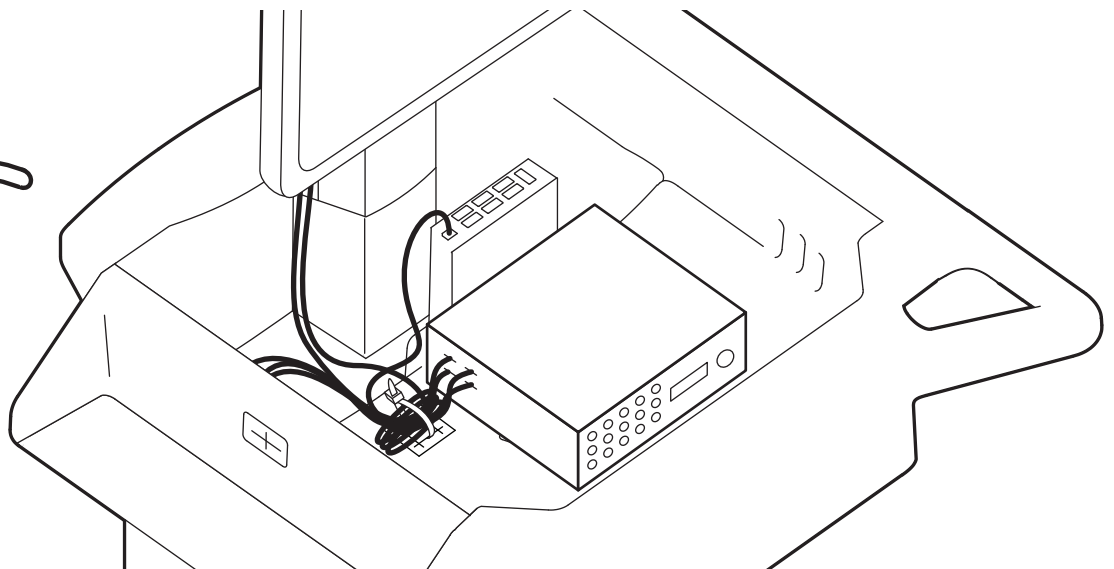

Optional Attachments and Features

Rotation Lock

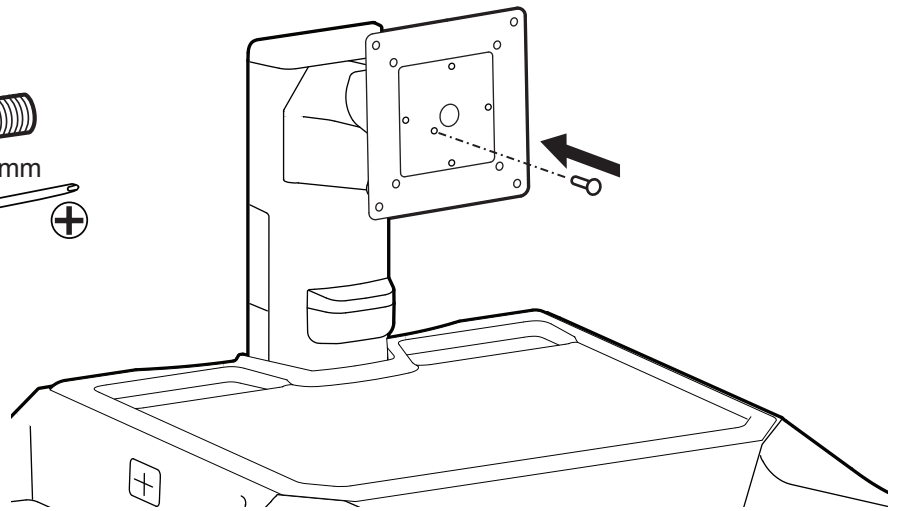
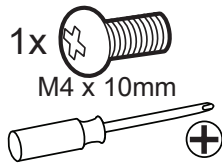
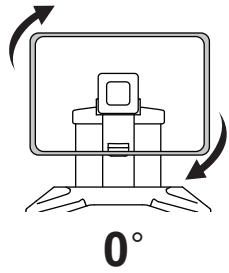

Monitor Lift Lock for monitors weighing 14 - 20 lbs (6.35-9.1 kg)
Insert screw at one of the two holes for desired LCD height.

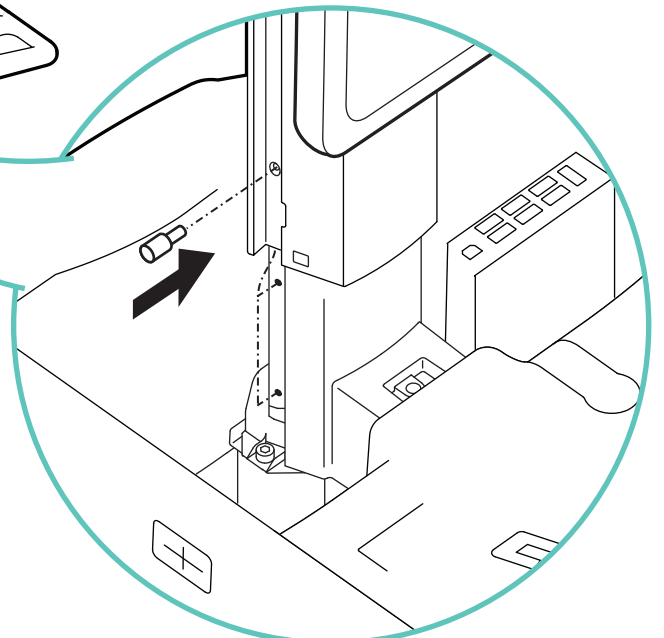
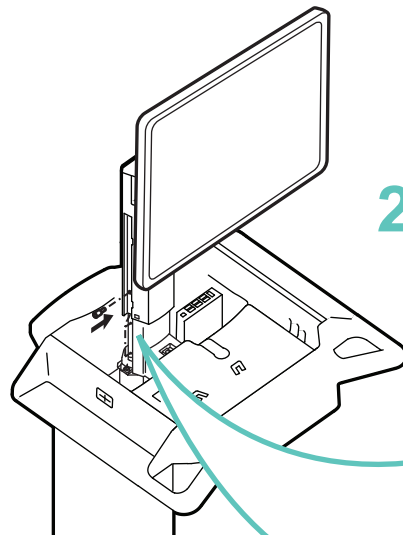
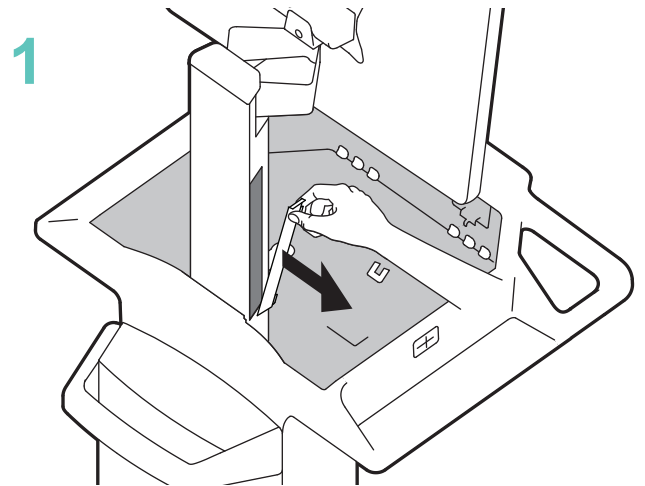
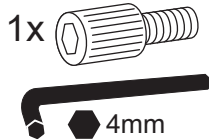
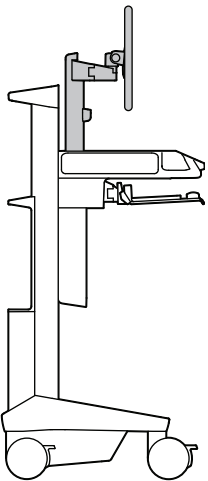

WARNING
AVERTISSEMENT

IMPACT HAZARD!
MOVING PARTS CAN CRUSH AND CUT.
Failure to heed this warning may result in serious personal injury or property damage!

Raise monitor to top of vertical adjustment BEFORE removing. DO NOT remove Stop Screw without monitor attached. Doing so will cause monitor pivot to shoot up rapidly and may cause personal injury.

DANGER D'IMPACT !
LES PARTIES EN MOUVEMENT PEUVENT ÉCRASER ET COUPER.
Il existe un risque de blessure corporelle ou d'endommagement matériel en cas de non respect de cet avertissement.

Élevez l'écran au plus haut de l'ajustement vertical AVANT de le retirer. NE retirez PAS la vis d'arrêt avant que l'écran soit fixé. Dans un tel cas, le pivot d'écran se relèverait rapidement et cela pourrait engendrer des blessures.

www.ergotron.com
829-503

Optional Attachments and Features

Follow these instructions to manually unlock drawers when cart has no power.

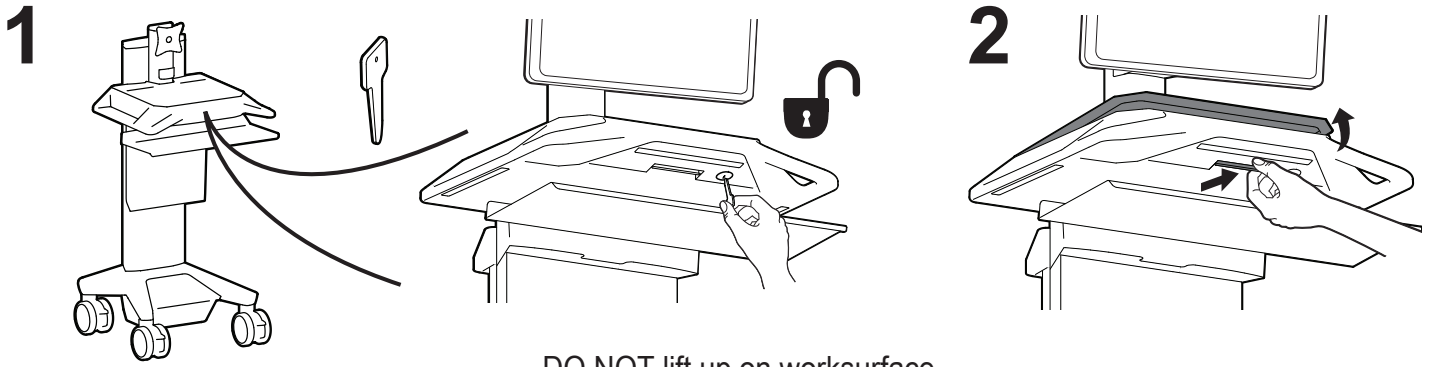

DO NOT lift up on worksurface.

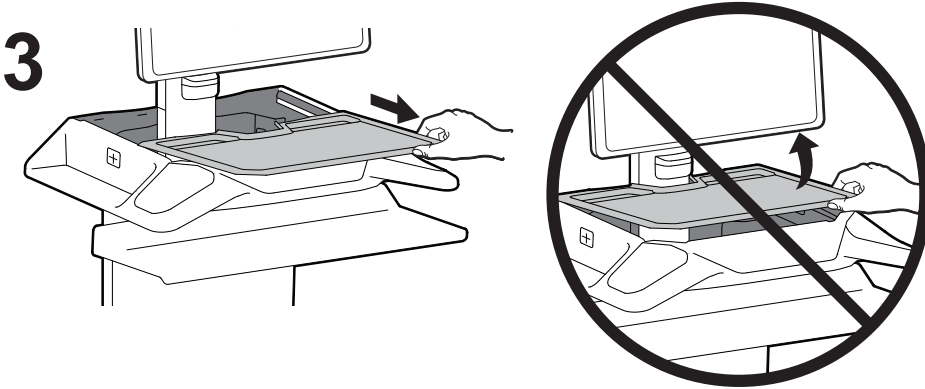

4 Remove cover then tighten screw while continuously testing drawers until they open and close freely.

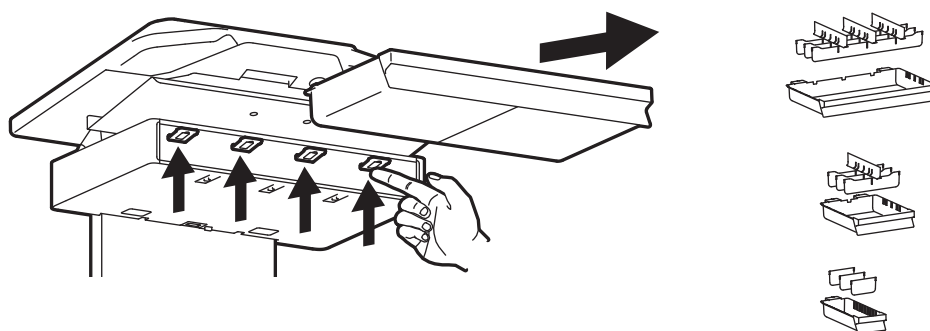
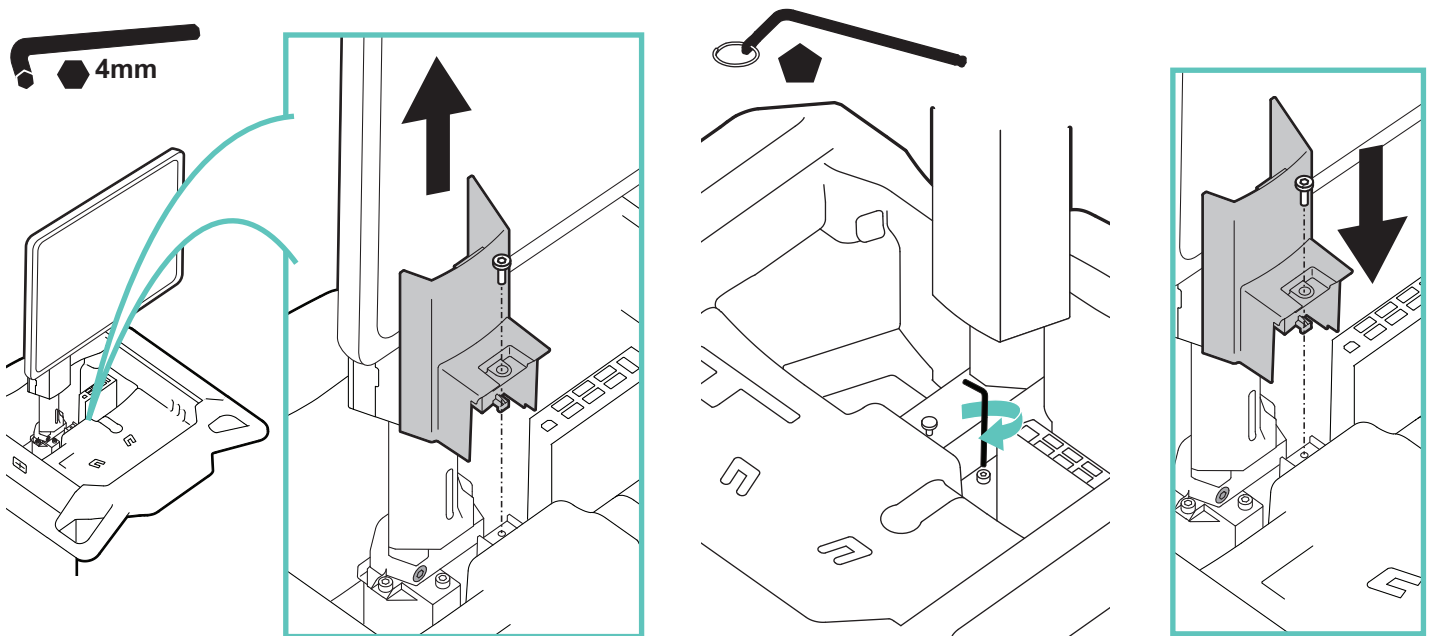

Replacing Batteries

Battery in Base of Cart

WARNING: The replacement of Lithium batteries by inadequately trained personnel could result in a hazard.

- 1 Turn off all mounted equipment.
Disconnect cart power cord from wall power.
Turn cart off.

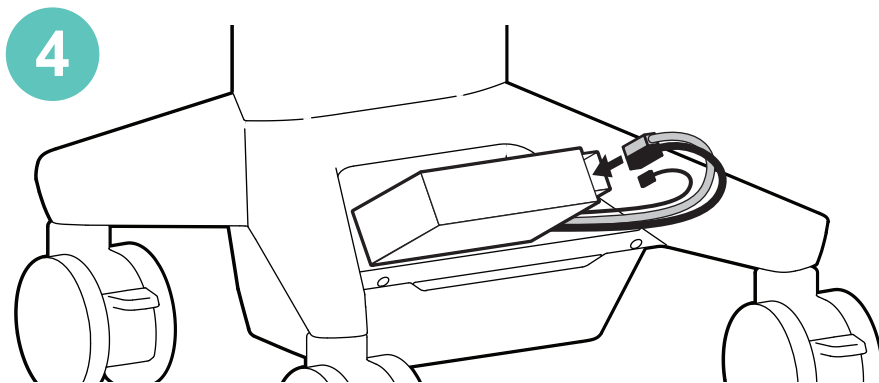
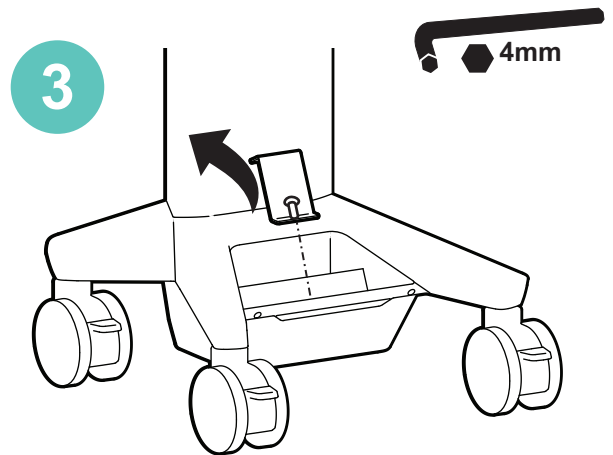
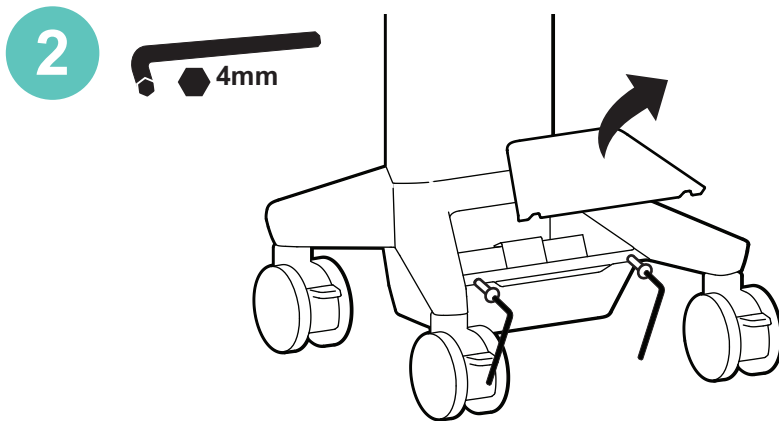
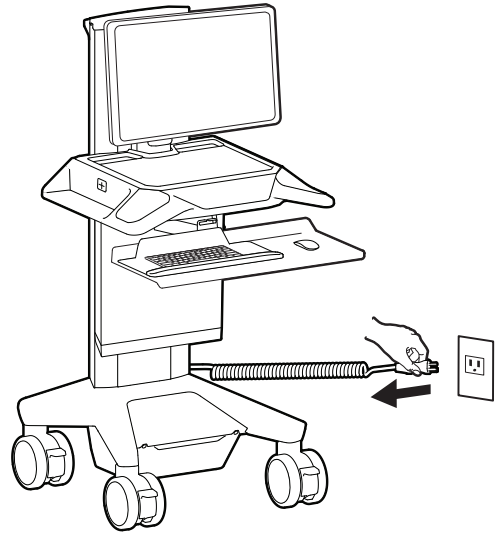

! CAUTION: Do NOT pinch battery cables. Pinching will cause damage to cables.

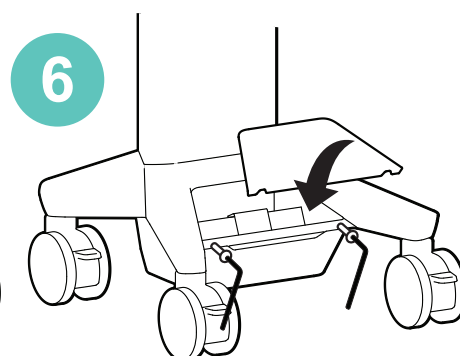
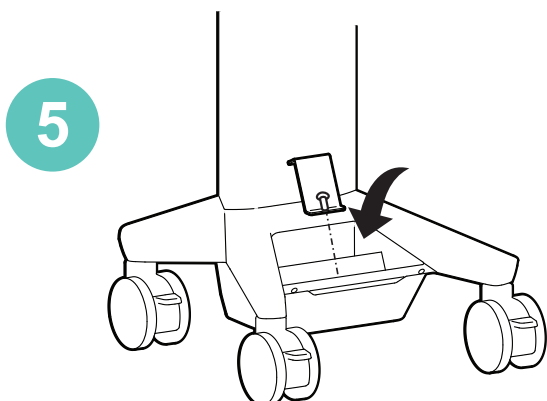

⚠ WARNING/AVERTISSEMENT

BATTERY REPLACEMENT

Only the following lithium batteries are compatible with this system:

GCT PN FPB-1173 Ergotron Part Number 916-438

Installing batteries other than the battery listed above will void the product warranty and result in power system malfunction. Failure to heed this warning may result in severe damage to batteries, power module and possible fire hazard.

REPLACEMENT DE LA BATTERIE

Seule la batterie suivante est compatible avec ce système : Batterie au lithium.

GCT PN FPB-1173 Numéro de pièce Ergotron : 916-438

L'installation de toute batterie autre que la batterie indiquée ci-dessus rendra nulle la garantie du produit et entraînera le dysfonctionnement du système d'alimentation. Si vous ne vous conformez pas à cette précaution d'utilisation, les batteries et le module d'alimentation risquent d'être sérieusement endommagés, ce qui pourrait provoquer un incendie.

829-520



Recycle the battery according to local regulations.

Battery will not charge when cart is turned off.

Cart Storage Instructions

Storage - The battery needs to be fully charged before storing and the battery must be recharged a minimum of every 90 days. The recommended cart storage temperature is 25°C (77°F). At this temperature, the battery's age-related capacity loss is minimized. The minimum storage temperature is -20°C (-4°F) and the maximum storage temperature is 50°C (122°F). The recommended humidity range for storage is 5-95% RH.

1. Turn off all mounted equipment.
2. Plug power cord into appropriate wall outlet to fully charge battery to 100%. Power system must be fully charged before storing!
3. Once battery has been charged to 100%, unplug cart and turn power system off. Turn cart off by holding down the Power button for 1 - 3 seconds. Screen will turn off.
4. Recharge battery a minimum of every 90 days.

NOTICE:

Warranty on fully charged batteries left in an unused state for more than three (3) consecutive months is automatically void.

Warranty on fully discharged batteries left in an unused state for more than three (3) consecutive days is automatically void.

If the battery is stored too long without recharging, the electronics in the battery may cause the battery voltage to drop to an unusable level. If this happens, the power system will enter a low charge recovery mode when plugged into power source. Once the process has finished the power system will resume charging as normal. If the low charge recovery process takes longer than 45 minutes please contact Ergotron Customer Care.

Specifications

This Class A digital apparatus complies with Canadian ICES-003.

Cet appareil numérique de la classe A est conforme à la norme NMB-003 du Canada.

FCC Compliance Statement

The cart has been tested and found to comply with the limits for a Class A digital device, pursuant to part 15 of the FCC Rules. These limits are designed to provide reasonable protection against harmful interference when the equipment is operated in a commercial environment. This equipment generates, uses, and can radiate radio frequency energy and, if not installed and used in accordance with the instruction manual, may cause harmful interference to radio communications. Operation of this equipment in a residential area is likely to cause harmful interference in which case the user will be required to correct the interference at his own expense.

Changes or modifications not expressly approved by Ergotron, Inc. could void the user's authority to operate the equipment.

Please contact Ergotron for complete EMC compatibility information.

Contains FCC ID: 2AVU2-C52XXXX1

ISED ID: 25915-C52XXXX1

ISED HVIN C52XXXX1

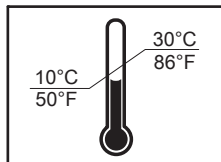

Operational Temperature Range

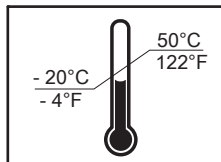

Storage Temperature Range



Relative Humidity Range



Part Number	Power System
C52-1211-1	Input: 120V~, 60Hz, 4.8A Max Output: 120V~, 60HZ, 150W, 150VA • The cart and power system are certified to ANSI/AAMI 60601 and CAN/CSA-C22.2 60601-1
C52-1211-2	Input: 100-240V~, 50/60Hz, 4.8-2.1A Max Output: 230V~, 50Hz, 150W, 150VA • The cart and power system are compliant with IEC 60601-1
C52-1211-3	
C52-1211-4	
C52-1211-C	

Specifications

Range of Motion

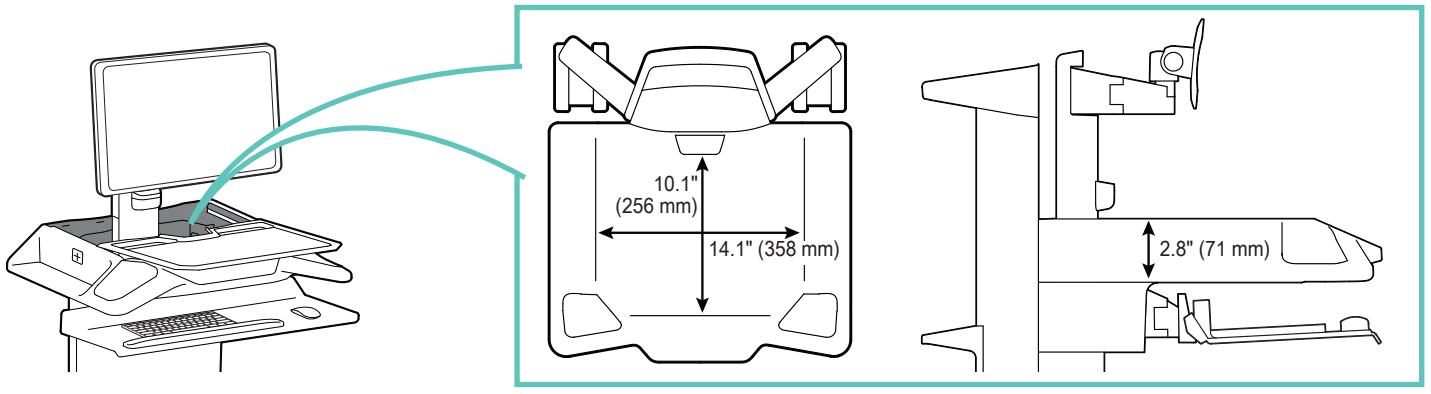
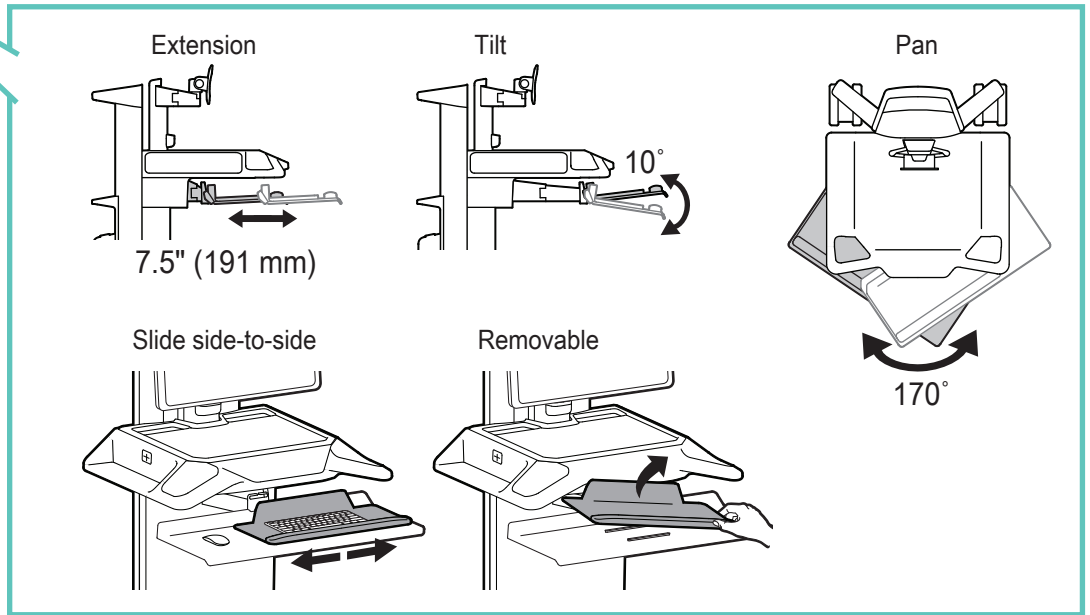
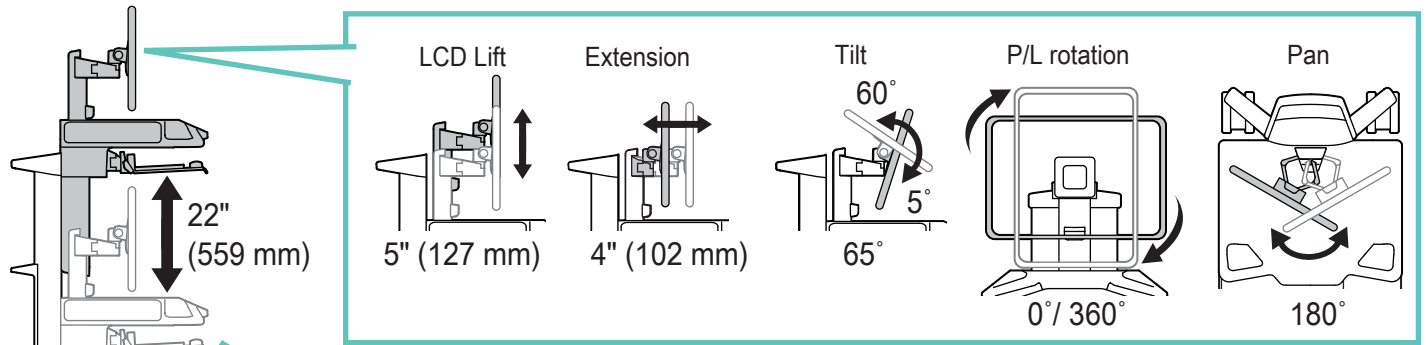

Weight Capacity

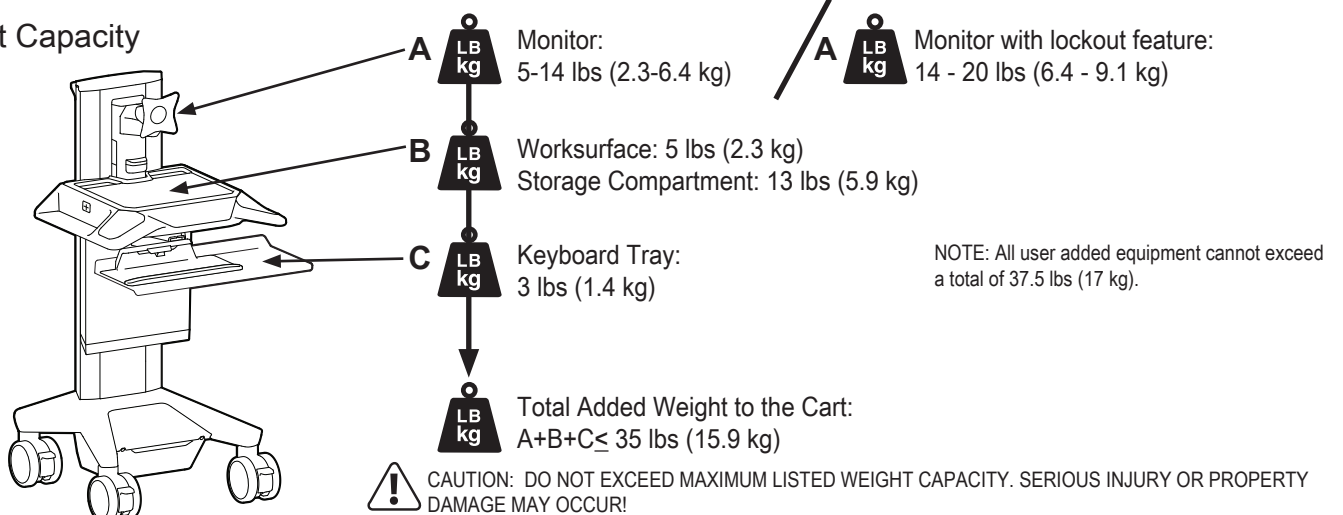

Specifications

Auto-Lock Drawer

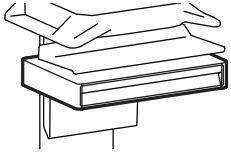

Max number of drawer rows per cart:
 1 single height row
 or 1 double height row

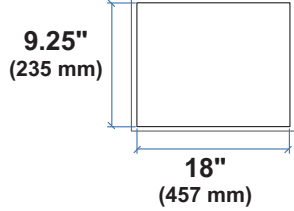
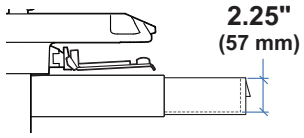

LB
kg Total weight capacity per drawer.
 ≤ 2 lbs (1 kg)

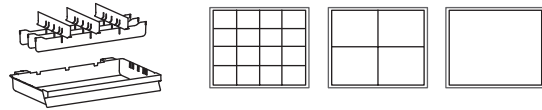

Drawer Lights

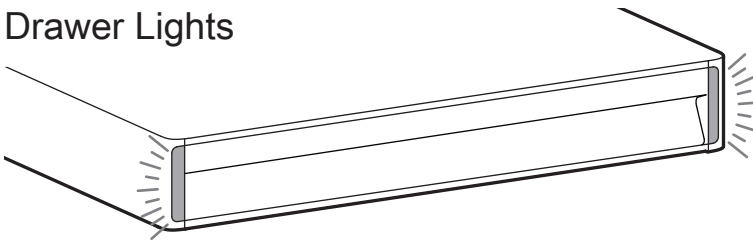







COLOR	MEANING
Green	When starting, the green light flashes to show drawers are communicating.
Blue - solid	A drawer in the row is open.
Blue - flashing	A drawer in the row has been open beyond the set time (Set time parameters in eKinnex).
Red - solid	The override is engaged. Electronic drawer function is disabled.
Red - flash once	The red LED will flash once if a drawer could not be unlocked. Do not pull on the drawer while it is unlocking and try again.
Red - flash 5 times	Invalid drawer configuration. Drawers were not installed correctly during startup. Make sure all drawers are closed, then restart cart.

Safety

Hazard Symbols Review

These symbols alert users of a safety condition that demands attention. All users should be able to recognize and understand the significance of the following Safety Hazards if encountered on the product or within the documentation. Children who are not able to recognize and respond appropriately to Safety Alerts should not use this product without adult supervision!

Symbol	Signal Word	Level of Hazard
	INSTRUCTIONS	Refer to instruction manual/booklet. Follow instructions for use.
	CAUTION	A CAUTION indicates either potential damage to hardware or loss of data and tells you how to avoid the problem.
	WARNING	A WARNING indicates either potential for property damage, personal injury, or death.
	DANGER	A DANGER indicates a hazardous situation that, if not avoided, will result in death or serious injury.
	Magnet	Magnets may be harmful to persons with implanted medical devices.
	DO NOT PUSH	Do Not push any part of cart other than the handle, cart may tip. Follow 'Moving' instructions in 'Ergonomics' section.

Safety Alerts Associated with this Product

The following Warnings/Cautions appear in this reference guide or on the cart:

NOTE: Failure to adhere to these guidelines may result in equipment damage or personal injury.

 CAUTION: The lift brake helps stabilize the worksurface and keyboard tray during normal use but it DOES NOT increase load capacity. DO NOT load riser with equipment totaling more than the maximum weight capacity specified by Ergotron. Ensure optimum lift function by testing and if necessary, re-adjusting tension whenever the weight mounted to the riser changes (i.e., equipment is removed or added). See "Set Riser Lift Tension" adjustment instructions.

 CAUTION: DO NOT overtighten fasteners. Overtightening may cause damage to your equipment.

 CAUTION: DO NOT loosen, tighten or remove any other nuts or bolts on the riser or top of tower. Tampering with nuts or bolts may result in an unstable Cart, leading to equipment damage and/or personal injury.

 CAUTION: Release Lift Brake before moving work surface! Moving work surface while Lift Brake is engaged may cause serious damage to Lift Engine.

 CAUTION: The power disconnect for this equipment is the AC power cable. Therefore the socket outlet should be easily accessible and should be installed near the equipment.

 CAUTION: All PCBA service needs to be completed by Ergotron technicians and requires ESD protection during service.

 WARNING: Do not operate Cart with missing or damaged components! Do not remove, modify or substitute Cart components without consulting Ergotron. If you encounter problems with Cart installation or operation, contact Ergotron Customer Care.

 WARNING: Stored Energy Hazard: The worksurface lift mechanism is under tension and will move up rapidly, on its own, as soon as attached equipment is removed. For this reason, DO NOT remove equipment unless the worksurface has been moved to the highest position on the tower! Failure to follow this instruction may result in serious personal injury and/or equipment damage! When Shipping the cart, set the worksurface lift mechanism to the lowest tension setting.

 WARNING: In the event that repair of the Cart is needed, contact Ergotron Customer Care immediately. Cart repair or modification can only be performed by Ergotron, Inc. or by an Ergotron authorized agent. All PCBA service needs to be completed by Ergotron technicians and requires ESD protection during service.

 WARNING: This cart is not intended for use in a flammable, anesthetic mixture or oxygen rich environment.

 WARNING! Connecting electrical equipment to the outlet effectively leads to creating a medical system and the result can be a reduced level of safety per IEC 60601-1.

 WARNING! Additional multiple socket-outlet or extension cord shall not be connected to the medical system.

 WARNING! When used in a Medical Electrical system, connect only equipment that complies with IEC, ISO, UL/ANSI, or CSA standards that are relevant to that equipment.

 WARNING! Risk of shock or personal injury when connecting non-medical equipment supplied as part of a system directly to the wall outlet when non-medical equipment is intended to be supplied by the multiple socket outlet.

 WARNING! Risk of shock or personal injury when connecting any equipment that has not been supplied as part of the medical system to the multiple socket outlet.

Safety



DANGER! Electrical cables can be hazardous. Misuse can result in fire or death by electrical shock.

WARNING
AVERTISSEMENT

IMPACT HAZARD!
MOVING PARTS CAN CRUSH AND CUT.
Failure to heed this warning may result in serious personal injury or property damage!
 Raise monitor to top of vertical adjustment BEFORE removing.
 Minimize Lift Tension BEFORE Shipping Cart or Storing Cart.

DANGER D'IMPACT !
LES PARTIES EN MOUVEMENT PEUVENT ÉCRASER ET COUPER.
Il existe un risque de blessure corporelle ou d'endommagement matériel en cas de non respect de cet avertissement.
 Élevez l'écran au plus haut de l'ajustement vertical AVANT de le retirer.
 Minimisez la tension d'élévation AVANT :
 d'expédier le chariot, de stocker le chariot

www.ergotron.com
829-464

Recommended Periodic Inspection and Maintenance			
Component	Action	How often	By whom
UI, Ethernet, USB cables	Inspect for wear, pinching, bad connectors	Monthly	Any user
Casters	Inspect for wear and debris	Monthly	Any user
Maximum Load	Inspect to ensure that maximum recommended loads are not exceeded	Daily	Any user
Power System batteries	Replace lithium battery ^{1,2}	When battery runtime is 60% of original runtime	IT Personnel
Power Module	Inspect for dust at intake, vacuum as required using a vacuum cleaner that DOES NOT generate ESD (Electrostatic Discharge)	Monthly	IT Personnel
Battery harness	Inspect for wear, cracking, pinching, or other damage	Monthly	IT Personnel
Coiled Cord	Inspect for wear, damage, or stretching	Weekly	Any user

1. Please dispose of all batteries in accordance with local law.
 2. Always replace battery with approved battery.

Earth Bond Test: To ensure safety grounding between the power cord ground connection and any accessible metal parts on the cart, although not mandatory, the following test is recommended to be performed every two years using a calibrated medical device safety analyzer. The procedure is as follows:

1. Disconnect the cart from mains power (unplug cart from the wall).
2. Remove power from internal power system outlets by pressing the power button on the cart's screen.
3. Set up Earth Bond Test per the medical device safety analyzer instructions.
4. Connect the Cart power cord to the medical device safety analyzer.
5. Remove cover to access Lift Tension Adjustment point.
6. Attach second medical safety device analyzer probe to Lift Tension Adjustment point on Cart.
7. Perform Test (25 amps).
8. Ensure Earth Bond is less than or equal to 0.1-ohms.
9. Remove medical device safety analyzer connections to Cart, replace cover over Lift Tension Adjustment point, return the Cart to service.

Safety

Ergotron Electromagnetic Guidance and Manufacturer's Declaration

Guidance and Manufacturer's Declaration – Electromagnetic Emissions		
The Powered Computer Cart is intended for use in the electromagnetic environment specified below. The customer or the user of the Powered Computer Cart should assure that it is used in such an environment.		
Emissions Test	Compliance	Electromagnetic environment – guidance
RF Emissions CISPR 11	Group 1	The Powered Computer Cart uses RF energy only for its internal function. Therefore, its RF emissions are very low and unlikely to cause any interference in nearby electronic equipment.
RF Emissions CISPR 11	Class A	
Harmonic Emissions IEC 61000-3-2	Class A	
Voltage fluctuations/ flicker emissions IEC 61000-3-3	Complies	

Guidance and Manufacturer's Declaration – Electromagnetic Immunity			
The Powered Computer Cart is intended for use in the electromagnetic environment specified below. The customer or the user of the Powered Computer Cart should assure that it is used in such an environment.			
Immunity Test	IEC 60601 Test Level	Compliance Level	Electromagnetic environment - guidance
Electrostatic Discharge (ESD) IEC 61000-4-2	±8 kV contact ±15 kV air	Complies	Floors should be wood, concrete, or ceramic tile. If floors are covered with synthetic material, the relative humidity should be at least 30%
Electrical Fast Transient/ Burst IEC 61000-4-3	±2 kV for power supply lines ±1 kV for input/output lines	Complies	Mains power quality should be that of a typical commercial or hospital environment.
Surge IEC 61000-4-5	±1 kV differential mode ±2 kV common mode	Complies	Mains power quality should be that of a typical commercial or hospital environment
Voltage Dips, short interruptions, and voltage variations on power supply input lines IEC 61000-4-11	<5% UT (>95% dip in UT) for 0.5 cycle 40% UT (60% dip in UT) for 5 cycles 70% UT (30% dip in UT) for 25 cycles <5% UT (>95% dip in UT) for 5 seconds	Complies	Mains power quality should be that of a typical commercial or hospital environment.
Power Frequency (50/60 Hz) Magnetic Field IEC 61000-4-8	30 A/m	Complies	Power frequency magnetic fields should be at levels characteristic of a typical location in a typical commercial or hospital environment.
Note: UT is the AC mains voltage prior to application of the test level			

Safety

Cleaning and Maintenance

The following procedures are not guaranteed to control infection. The hospital infection control administrator or epidemiologist should be consulted regarding cleaning procedures and processes.

- ⚠ To avoid risk of electric shock, do not expose electrical components to water, cleaning solutions or other potentially corrosive liquids or substances.
- ⚠ Do not immerse Cart or Cart components in liquid or allow liquids to flow into the Cart. Wipe all cleaners off surface immediately using a damp cloth. Thoroughly dry surface after cleaning.

- ⚠ Do not use flammable cleaners on Cart surfaces due to close proximity of electrical power and equipment.

All paints and plastic Cart components will withstand cleaning by most commonly used, diluted, non-abrasive solutions such as quaternary ammonia compounds, ammonia enzyme cleaners, bleach or alcohol solutions.

- Pen and permanent and dry erase markers can be removed from plastic components with 91% isopropyl alcohol and a soft cloth.
- Iodine stains can be removed with commonly used cleaners and a soft cloth.
- Never use steel wool or other abrasive materials that will damage the surface finish.
- Do not use strong solvents such as trichloroethylene and acetone. These solvents will damage the surface finish.

It is recommended that any cleaning solution be tested on a small, inconspicuous area to ensure surface is not harmed.

- ⚠ Adjustment, Service, Replacement - DO NOT attempt to adjust, service or replace any part of the Cart unless directed to do so through Ergotron-approved documentation (i.e. installation instructions). Only Ergotron, Inc. or an Ergotron-certified entity may adjust, service or replace Cart components. If any component on the Cart is missing or damaged, the Cart must not be used, contact Ergotron Customer Care immediately to request a replacement part.

- ⚠ Cables - Keep cables neatly organized on the Cart (a variety of solutions are provided with your cart for this purpose). Excess cables should be routed away from moving components with cable clips. Review Cable Routing section of this guide, or contact Ergotron Customer Care for more information.

- ⚠ Casters - Check casters periodically to make sure they are clean and free of debris that would prevent smooth travel. Avoid moving Cart across uneven, dirty or damaged surfaces.

- ⚠ Customer Equipment- Make sure equipment is balanced and mounted securely to Cart. Do not reposition Cart components on riser or tower unless instructed to do so in the installation instructions. Moving Cart components too high or too low on the Riser may create an unstable condition, leading to equipment damage or even personal injury. Contact Ergotron Customer Care for information about moving Cart components.

- ⚠ WARNING: In rare cases, if the power system and battery protection features fail, the battery may become overcharged and in some instances it may become extremely hot, possibly melting the plastics and releasing smoke. If a battery begins to smoke or melt:

- Unplug the cart, or if possible disconnect the battery from the power system immediately.
- Move the cart to a well ventilated area.
- Use a Carbon Dioxide, Dry Chemical or appropriate foam fire extinguisher to spray the hot battery.

If a fire extinguisher is not available, use copious amounts of water, or cover the battery with sand.

If exposed to battery contents seek immediate medical attention and follow the below guidelines.

Exposure to vapor released from the battery is irritating to the eyes, skin, mucous membranes and respiratory tract. This may cause nausea, dizziness and headache.

In case of direct contact to the battery's electrolyte:

- Immediately flush eyes with water for at least 15 minutes.
- Thoroughly rinse hands and other affected areas with water.
- Promptly remove and wash any contaminated clothing.

In All Cases, Seek Immediate Medical Attention!



Equipment & Accessories Disposal

1. Please dispose of all batteries in accordance with local law
2. All Electronics should be recycled through an electronics recycler.
3. Remaining plastics and metals can be recycled through a commercial recycler.

For the latest User Installation Guide please visit: www.ergotron.com

For Warranty visit: www.ergotron.com/warranty

For Service visit: www.ergotron.com

For local customer care phone numbers visit: <http://contact.ergotron.com>

NOTE: When contacting customer service, reference the serial number.

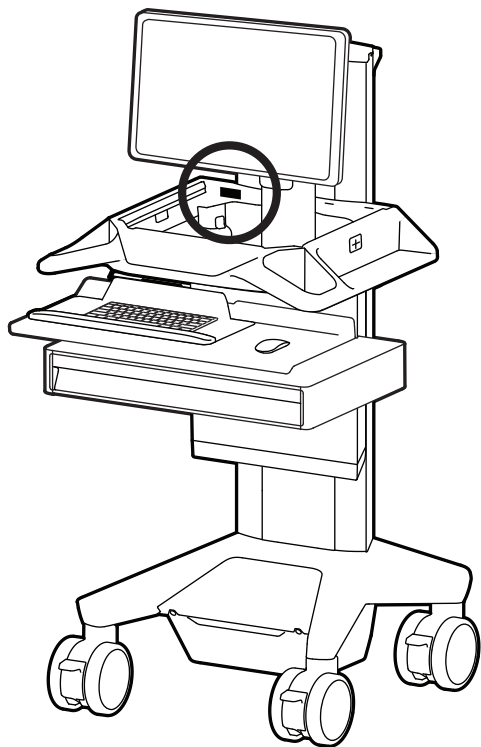

ergotron®

www.ergotron.com | USA: 1-800-888-8458 | Europe: +31 (0)33-45 45 600 | China: 400-120-3051 | Japan: japansupport@ergotron.com

© 2020 Ergotron, Inc. All rights reserved. CareFit™ and Constant Force™ are registered trademarks of Ergotron, Inc.

While Ergotron, Inc. makes every effort to provide accurate and complete information on the installation and use of its products, it will not be held liable for any editorial errors or omissions (including those made in the process of translation from English to another language), or for incidental, special or consequential damages of any nature resulting from furnishing this instruction and performance of equipment in connection with this instruction. Ergotron, Inc. reserves the right to make changes in the product design and/or product documentation without notification to its users. For the most current product information, or to know if this document is available in languages other than those herein, please contact Ergotron. No part of this publication may be reproduced, stored in a retrieval system, or transmitted in any form or by any means, electronic, mechanical, photocopying, recording or otherwise without the prior written consent of Ergotron, Inc., 1181 Trapp Road, Eagan, Minnesota, 55121, USA Patents Pending and Patented U.S. & Foreign. Ergotron is a registered trademark of Ergotron, Inc.