

Product Description

These premier built-in undercounter freezers are designed in accordance with the NSF/ANSI 456 Standard for Vaccine Storage. Units protect pharmaceuticals at optimal temperatures, preventing waste and allowing for peak delivery.

The freezers utilize microprocessor controllers and feature temperature alarms, remote alarm contacts, and probe access ports with included probes. American Biotech Supply Vaccine Storage Freezers utilize HFC-free refrigerant for environmental health and energy efficiency.

General Description and Application

Description	Single Solid Door Pharmacy/Vaccine Undercounter Manual Defrost Freezer Built-In
Operational environment	Indoor use only, +18°C to +26°C (+65°F to +78°F), <70% RH
Storage capacity	4.2 cu. ft. gross volume
Door	One swing solid door, self-closing, right hinged, non-reversible, magnetic sealed gasket, keyed lock
Shelves	Two shelves, fixed
Mounting	Low profile roller wheels and leveling legs
Interior lighting	N/A
External probe access	Rear wall port (3/4" dia.)
Insulation	Cabinet is foamed-in-place with EPA compliant high density urethane foam
Exterior materials	Stainless Steel
Access control	Pyxis®, Omnicell® and AcuDose RX® compatible
General warranty	Two (2) years parts and labor warranty, excluding display probe calibration
Compressor warranty	Five (5) years compressor warranty
Product Weight	100 lbs.
Shipping Weight	132 lbs.
Rated Amperage	1.5 Amps
Power Plug/Power Cord	NEMA 5-15 plug, 8 to 10 ft typical, conforms to UL471 requirements, Vaccine storage power cord warning label
Facility Electrical Requirement	110-120V AC: 15 A (minimum)
Agency Listing and Certification	Compliant with the thermal performance requirements as defined in the NSF/ANSI 456 Standard for Vaccine Storage for all testing protocols. UL, C-UL, ETL, C-ETL listed (either single or dual agency listings) and certified to UL471 standard, hydrocarbon refrigerant safety. Energy Star Certified.
Included Accessories	Pharmacy refrigerator/freezer toolkit and temperature logs

Refrigeration System

Compressor	Hermetic, high performance
Refrigerant	EPA SNAP compliant, R600a, Isobutane
Condenser	Hybrid fin and tube with low noise fan
Evaporator	Integrated shelf evaporator design
Defrost	Manual

Performance

Uniformity ¹ (Cabinet air)	+/- 2.6°C
Stability ² (Cabinet air)	+/- 2.1°C
Maximum temperature variation (Cabinet air)	+/- 2.9°C
Temperature rise after 5 sec door openings	Temperature did not exceed -17.5°C at any probe for all required NSF/ANSI 456 testing protocols ³
Recovery after 60 sec door opening	All probes recover to under -15°C within 8.2 min.
Energy consumption	0.97 KWh/day ⁴
Average heat rejection	1.97 KWh/day (224 BTU/h) ⁴
Noise pressure level (dBA)	49 or less installed
Pull down time to nominal operating temp	51 min

Controller, Configuration, Alarms and Monitoring

Controller technology	Parametric, microprocessor, LED display with 0.1°C resolution
Temperature setpoint range	-15°C to -28°C (Controller settings must remain unaltered to ensure thermal performance compliant with NSF/ANSI 456 requirements)
Calibration	Calibrated using a NIST traceable device, certificate included
External alarm connection	State switching remote alarm contacts Visual and audible indicators
Alarms	High / Low temperature, compliant with alarm requirements defined in the NSF/ANSI 456 Standard for Vaccine Storage
Simulator ballast	Glass bead thermal media

Performance data acquired at 22°C ambient, using NSF/ANSI 456 compliant validation ballast probes, empty chamber, during stabilized steady state operation and a DAQ sampling rate of one measurement every 10 seconds

- 1 - Uniformity is defined as the maximum variance in temperature across all probes at any point in time over the testing period
- 2 - Stability is defined as the maximum variance in temperature experienced by any single probe over the testing period
- 3 - Temperature performance for all loaded and unloaded door opening protocols, all alarm, controller and probe requirements as defined in the NSF/ANSI 456 standard for vaccine storage
- 4 - Data per Energy Star test results or equivalent testing and calculation. Heat rejection based on daily averages, not continuous operation. Performance exceeds Energy Star requirements.

Certifications



Intertek

*-one or more of these certifications may apply to this unit.

Temperature Probes

Probe	Ave	Min	Max
1	-22.6	-23.2	-22.0
2	-22.3	-22.8	-21.8
3	-25.4	-26.0	-24.6
4	-23.1	-23.7	-22.6
5	-25.1	-25.7	-24.4
6	-23.3	-23.8	-22.8
7	-24.9	-25.5	-24.2
8	-26.2	-27.0	-25.4
9	-24.2	-24.7	-23.8
10	-26.6	-27.6	-25.5
11	-23.2	-23.8	-22.6
12	-22.9	-23.6	-22.3
13	-22.6	-23.5	-22.0
14	-23.5	-24.2	-22.8
15	-26.4	-27.4	-25.4

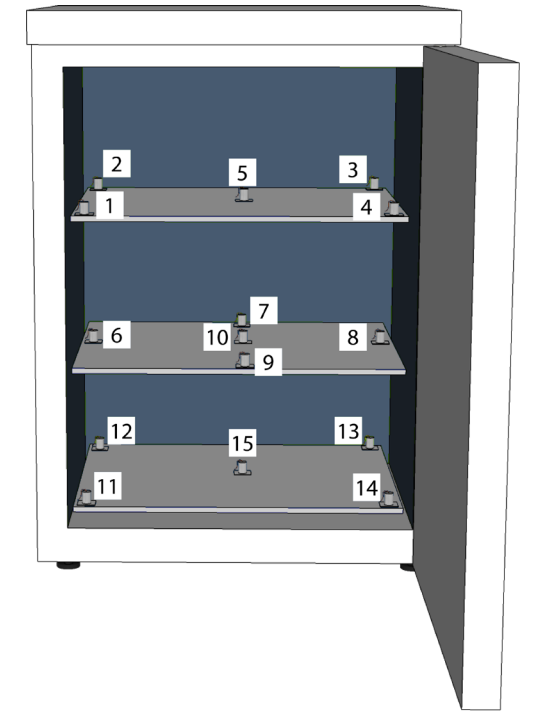

Temperature Charts

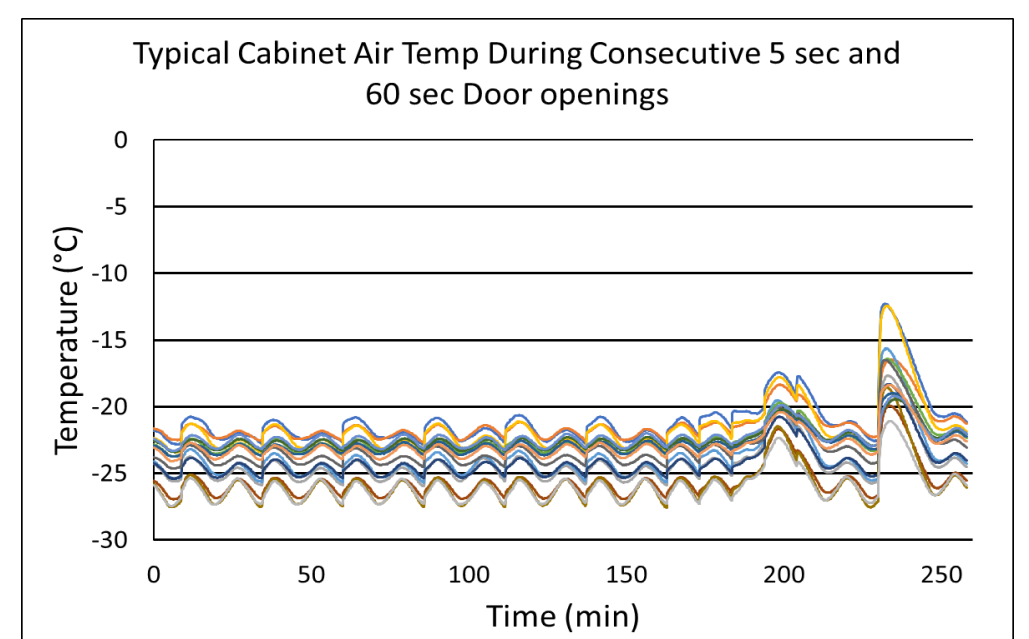
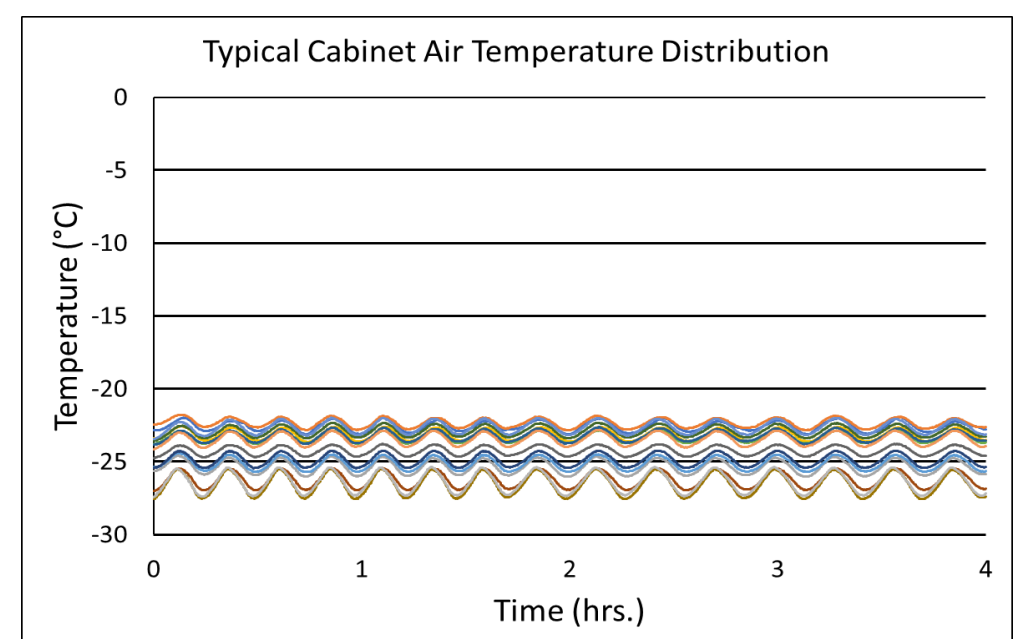
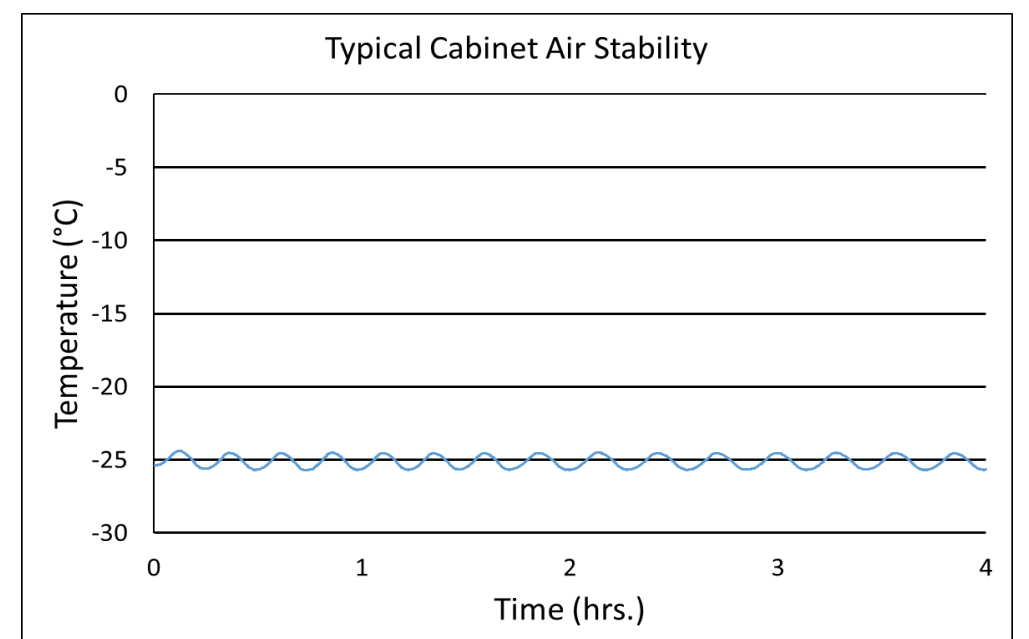

Images



Dimensions

	Width	Depth	Height	Door Swing	Total open Depth
Exterior	23 3/4"	24 1/2"	33 3/8"	21 3/4"	46"
Interior	19"	17 1/4"	21"		

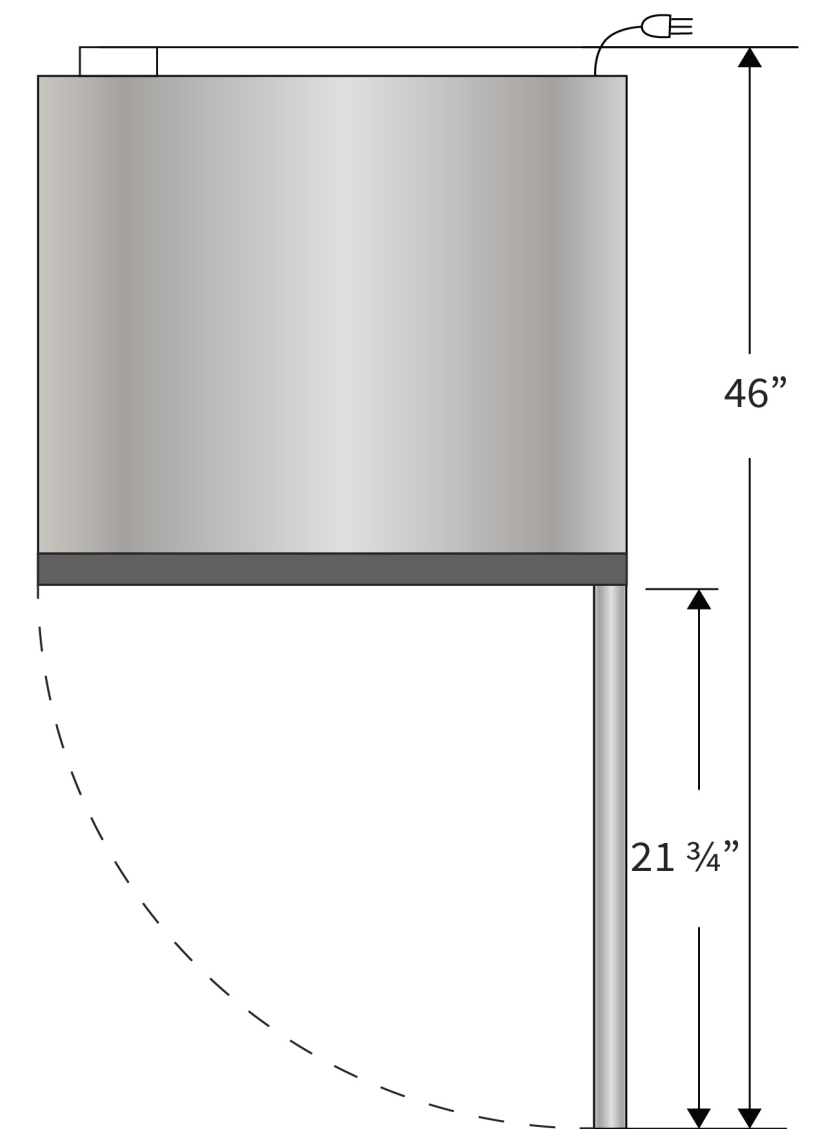
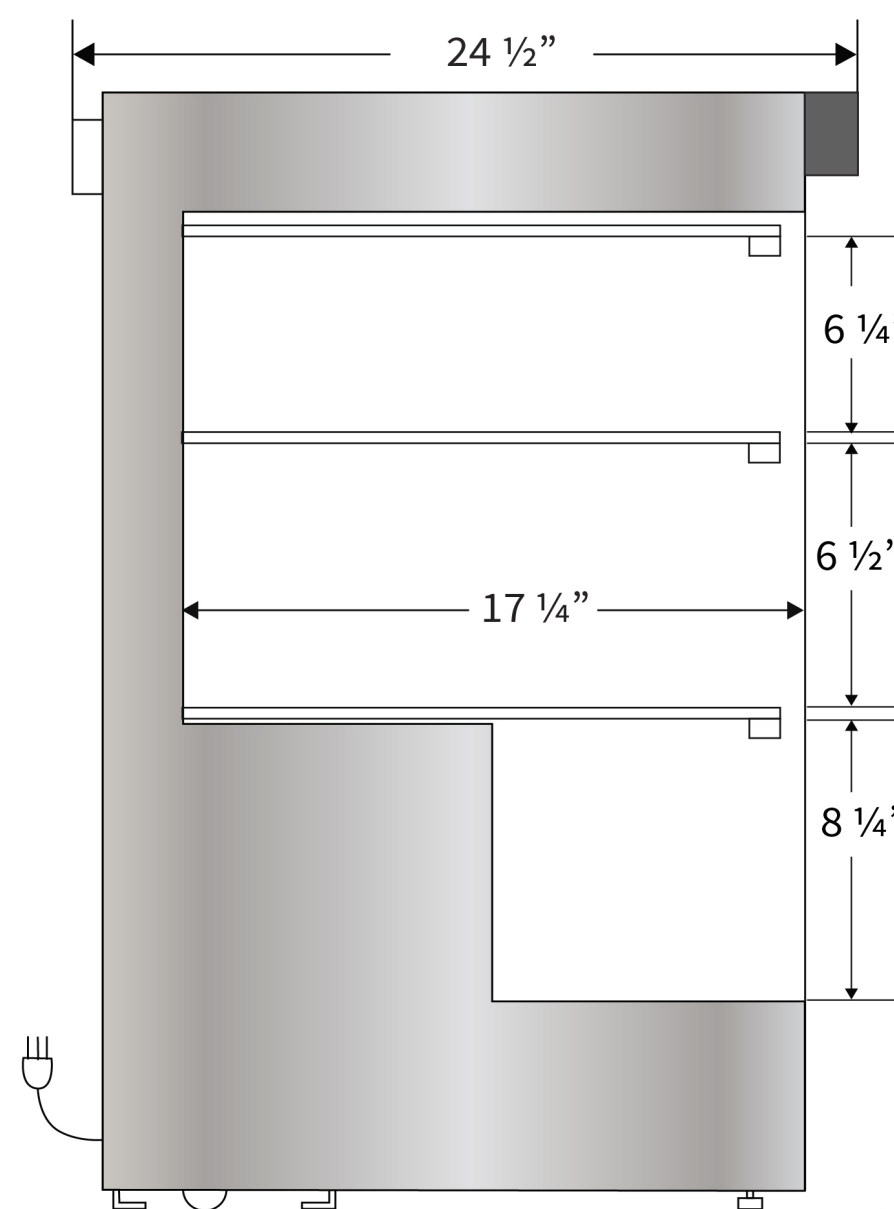
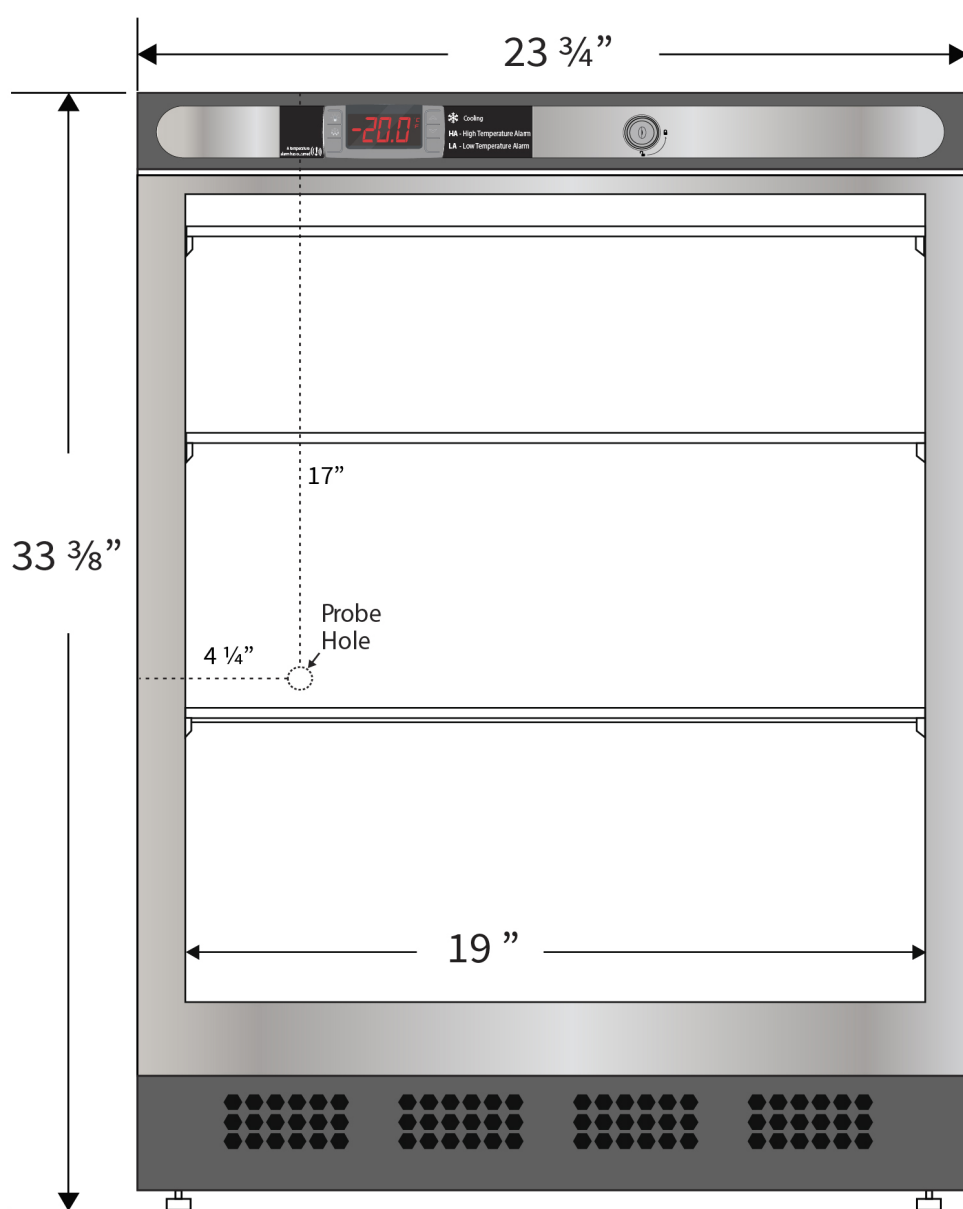

Contact