



CARTS/  
SHELVING/  
WORKCENTERS/  
MOBILE COMPUTING/  
AUTOMATED DISPENSING/



2014

HEALTHCARE  
PRODUCT CATALOG



# Advantage



“Let us help manage your space. Take advantage of our layout and design services.”



Examples of 3D Product and Application Visualization

## Looking for high-touch services?

Metro can make everything from application visualization to custom packaging easy.

### Professional Services Available:

- “Space Audits” to Maximize Your Storage Potential
- Product Planning and Room Layout
- Project Quoting and Management
- 3D Product and Application Visualization
- Custom Product Design and Engineering
- Product Prototyping and Samples
- Custom Packaging



# Metro.

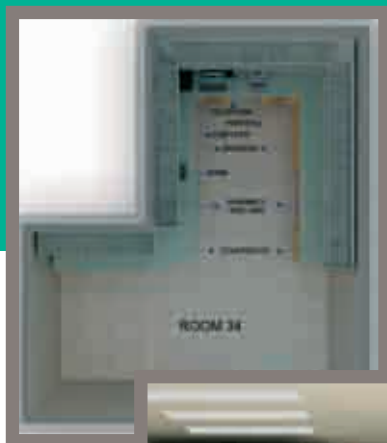

## Self-Service Tools

- Web-Based Room Layout and Product Planning
- Web-Based Product Configuration
- Web-Based Learning Modules

*Visit [metroconfigurator.com](http://metroconfigurator.com) and test drive the Configurator...our web based software developed to give you the power to manage your space.*



# CONTENTS

Value Added Services.....Inside Front Cover-3  
 Table of Contents..... 4-5  
 Metro Shelving Systems..... 6-7

## Polymer Shelving Solutions..... 8-28

iQ System Overview ..... 10-11  
 How MetroMax i® & MetroMax Q® Integrate ..... 12-13  
 Build-a-shelf with the iQ Shelving System ..... 14-15  
 Casters, Pull & Push Handles ..... 16-17  
 Mobile Shelving Units & Utility Carts ..... 18-19  
 Starter & Add-On Units ..... 20-21  
 System Accessories ..... 22-28

## Wire and Solid Shelving Solutions ..... 30-71

Wire/Polymer Hybrid Shelving ..... 32-35  
 Easy-Adjust Shelving & Carts ..... 36-39  
 Wire Shelving, Carts & Trucks..... 40-49  
 Casters & Accessories for Wire Shelving..... 50-64  
 Solid Shelving & Accessories..... 66-68  
 Light-Duty Wire Shelving & Accessories ..... 69  
 Heavy-Duty Solid Shelving & Accessories ..... 70-71

## Wall Shelving & Carts..... 72-89

Wall Shelving & Storage Systems ..... 74-82  
 Premium Polymer Utility Carts ..... 83  
 Polymer Utility Carts ..... 84-86  
 Utility Carts..... 87-88  
 Heavy-Duty Utility Carts..... 89

## High-Density Storage, Dunnage & Security .....90-109

High-Density Movable Aisle Shelving ..... 92-99  
 Vertical High-Density Shelving ..... 100  
 Dunnage Racks & Shelves ..... 101-102  
 Security Storage..... 103-107  
 Seismic Shelving..... 108-109

# CONTENTS

## Point-of-Care Computing Medication Management..... 112-137

- Point-of-Care Mobile Workstations..... 114-121
- Automated Dispensing Systems ..... 122-125
- Medication Carts & Wall Cabinets..... 126-129
- Pharmacy Fixtures..... 130-135
- MetroESP Enhanced Service Program ..... 136-137

## Enclosed Storage, Transport & WorkStations ..... 138-173

- Overview..... 140
- Cart Overview ..... 141
- Procedure Carts — Modular ..... 142-150
- Supply Units/Carts/Cabinets & Accessories ..... 151-159
- Mobile WorkCenters ..... 160-161
- Stationary WorkCenters & Accessories ..... 162-166
- Overhead Units & Accessories..... 167-169
- Specialty Units/Storage & Accessories ..... 170-172

## Carts..... 174-229

- Emergency Carts..... 176-181
- Procedure Carts — Polymer ..... 182-193
- Procedure Carts — Metal ..... 194-211
- Case Carts ..... 212-213
- Procedural Support ..... 214
- Specialty Carts & Storage ..... 215-218
- Storage & Transport/Exchange Carts..... 219-225
- Totes, Slides & Accessories..... 226-227
- Linen Carts and Trucks..... 228-229

## Work Stations..... 230-237

- Process Tables & Accessories ..... 232-235
- Worktables & Accessories..... 236-237

Terms and Conditions ..... 238-240

Index ..... Inside Back Cover

Locations ..... Back Cover



Superior materials and design for every application.

# Engineered for use and abuse.

Robust Steel Corners • Reinforced Support Trusses  
Durable Finishes • Advanced Polymer Materials • Type 304 Stainless Steel  
Easy-to-Adjust in Increments of 1" (25mm)



	MetroMax i <sup>®</sup> Polymer	MetroMax Q <sup>®</sup> Polymer & Epoxy Coated Steel	Stainless Steel Solid/S A Wire	Super Erecta <sup>®</sup> Pro Epoxy Coated Steel with Polymer Mat	Super Adjustable <sup>™</sup> Wire Shelving Epoxy Coated/Plated	Super Erecta <sup>®</sup> Wire Shelving Epoxy Coated/Plated
Clean Design	●	●	●/○	●	○/●	○/●
Antimicrobial Protection	●	●	N/A	●	●/N/A	●/N/A
Smooth Surfaces/Tear Protection	●	●	●/○	●	○	○
Quick to Adjust	●	●	○/●	○	●	○
Storage Capacity	●	●	●/●	●	●	●
Organization	●	●	○/●	●	●	●
Accessories	●	●	○	●	●	●
Weight Capacity	●	●	●	●	●	●
Corrosion Protection	●	●	●	●	○/●	○/●
Abrasion Resistant	●	●	●	●	○/●	○/●
Chemical Resistance	●	●	●	●	○	○
High-Temperature Cart Wash	○	●	●	●	●	●
Autoclave Sterilization	●	●	●	●	●	●

†Refers to MetroMax Q protective epoxy coating

\*Refers to Metroseal 3 protective epoxy coating

- Excellent
- Above Average
- Average
- Below Average
- Not Recommended
- N/A Not Applicable



\*MICROBAN<sup>®</sup> antimicrobial product protection helps keep shelves “cleaner between cleanings” by inhibiting the growth of mold, mildew, fungus, and bacteria that cause odors and stains on the shelf surface. MICROBAN<sup>®</sup> and the MICROBAN<sup>®</sup> symbol are registered trademarks of the Microban Products Company, Huntersville, NC.



Metro incorporates several elements in its product design to support a facility’s cleaning protocols:

- Microban<sup>®</sup> antimicrobial protection helps prevent the growth of stain and odor causing bacteria on the product.
- Advanced polymer and other proprietary finishes provide corrosion resistance
- Smooth rounded corners to allow for easier cleaning

Look for the “red check” symbol for this added protection.



Metro’s shelving systems are listed with NSF International (National Sanitation Foundation). Visit [www.metro.com/NSF](http://www.metro.com/NSF) for more information.

## MetroMax i®

“The ultimate storage and handling system with a lifetime guarantee against rust”



## MetroMax Q®

“Quick to Clean  
Quick to Adjust  
Quick to Assemble”

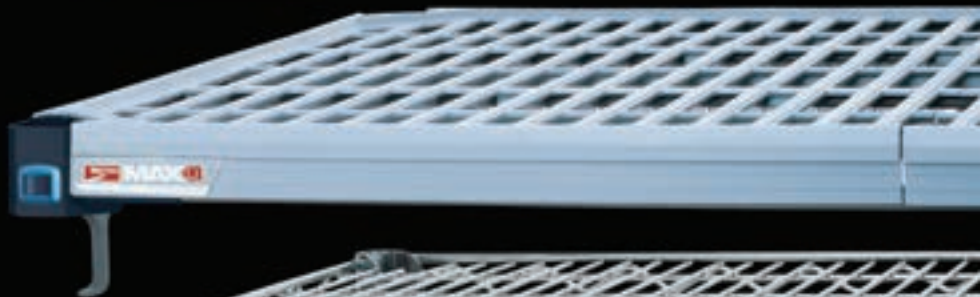

## Super Adjustable Super Erecta®

“The easiest to adjust wire shelving system ever”

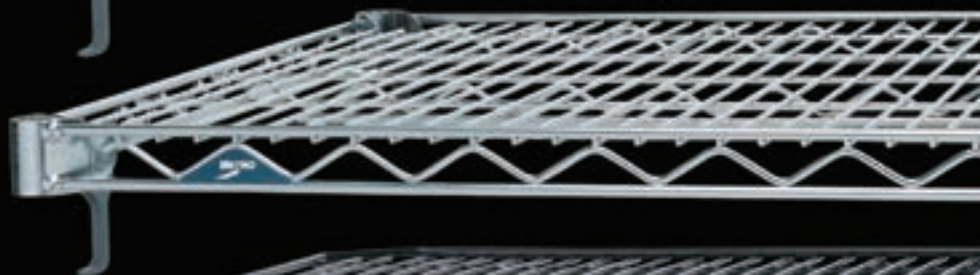

## qwikSLOT™

“Add-A-Shelf,  
Remove-A-Shelf . . .  
Instantly”



## Super Erecta Pro™

“Durable and Cleanable.  
The original — reinnovated.”



## Super Erecta®

“The Original Wire Storage and Handling System”

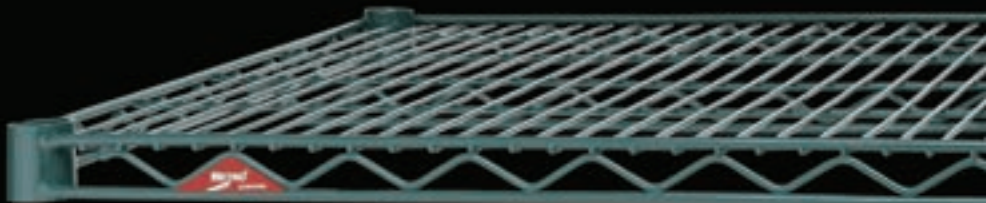

## Drop Mat™

“Provides density and containment economically”

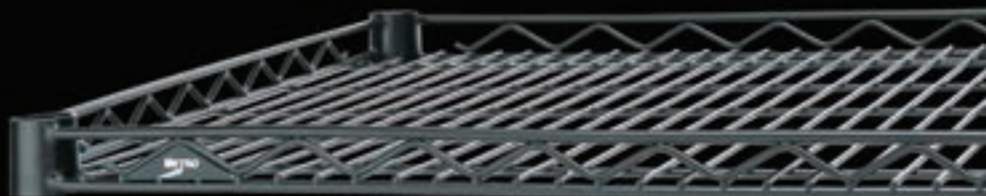

## Super Erecta® Solid

“A solid performer in the proven Super Erecta style”





# POLYMER SHELVING SOLUTIONS

## MetroMax iQ® Storage System

iQ System Overview .....	10-11
How MetroMax i® & MetroMax Q® Integrate .....	12-13
Build-a-shelf with the iQ Shelving System .....	14-15
Casters, Pull & Push Handles .....	16-17
Mobile Shelving Units & Utility Carts .....	18-19
Starter & Add-On Units .....	20-21
System Accessories .....	22-28

# uniQ<sup>ue</sup> equation.

**i + Q = iQ** ... now that's smart.

## Uniquely Justifiable

*"Budgets are tight . . . so we need to make every dollar last."*

**MetroMax i<sup>®</sup>**  
Uniquely Lifelong...



## Uniquely Cleanable

*"Removable mats are a must in any industry, so cleanable."*

**MetroMax Q<sup>®</sup>**  
Unique Value...



## Uniquely Interchangeable

*"We're looking for a smart system that lets us interchange and upgrade components to meet new and changing tasks."*

## Uniquely Durable

*"We needed a system as strong as our Metro racks but with protected surfaces that won't scratch and chip. The polymer shelf mats and posts definitely hold up to all the abuse, plus the mats are really easy to clean."*

# MetroMax iQ® Storage System

**Interchangeability:** MetroMax i® and MetroMax Q® shelves, posts, and most accessories are uniquely interchangeable making the iQ system adaptable to your specific application.

**Longer-Life Durability and Performance:** Corrosion proof MetroMax i® has an innovative polymer design and the performance of stainless steel at a fraction of the cost. MetroMax Q® has an advanced polymer and epoxy coated steel design that offers superior performance versus wire shelving. All shelves hold as much weight as wire shelves, but also offer protective polymer surfaces for long life and easily removable shelf mats that can be cleaned in a fraction of the time of wire.

Designed with innovative polymers for longer-life product performance, easy-to-clean surfaces to promote a cleaner environment and higher level of safety, interchangeable components for maximum flexibility, interactive on-line tools . . . a truly unique way to improve operational efficiencies, productivity, and ultimately ROI.



**Improved Cleanability:** iQ System shelves have removable polymer mats that are easily cleaned in sinks, wash or dish machines. Cleaner shelves promote safe environments.

**Storage Optimization:** iQ System accessories contain, compartmentalize, and organize your stored contents to maximize every square inch of storage space. Smooth polymer components protect fragile packaged items.



We put space to work.™



# MetroMax i® Uniquely Lifelong ...

- Corrosion Proof, Lifetime Warranty Against Corrosion
- Polymer Construction with Stainless Steel Corners
- All Polymer Posts
- Removable, Easily Cleanable Polymer Shelf Mats
- Open Grid and Solid Shelves



### Interchangeable Posts



### Interchangeable Shelves

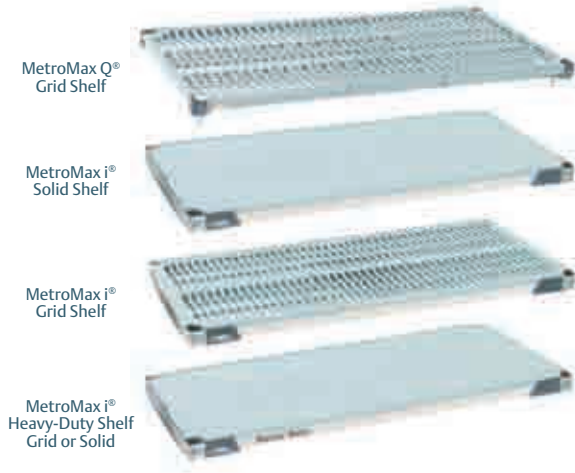

## Selecting system components for your



*“The choice was easy... Our facility needed the most cleanable, most durable, and totally corrosion proof system available, and MetroMax i® was all that and cost efficient.”*



*“We put extremely heavy loads on our MetroMax i Top-Track system, so we opted for the steel posts for added rigidity.”*



## MetroMax Q® Unique Value ...

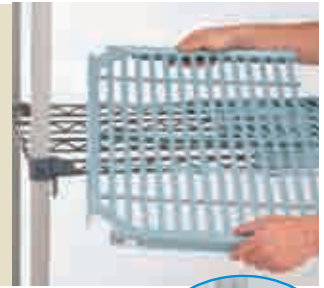

- Quick-to-adjust Shelves Provide Maximum Space Utilization
- Corrosion Resistant, 15 Year Warranty Against Corrosion
- Epoxy Coated Wire Shelf Frames and Posts
- Removable, Easily Cleanable Polymer Shelf Mats
- Open Grid Shelves



### Strong.

All shelves are designed with robust steel corners and reinforced center trusses for the strength you need in both stationary and mobile configurations. Shelves up to 48" (1219mm) long hold 800 lbs. (363kg). A four-shelf unit can hold 2,000 lbs. (907kg).



All shelf mats, posts, and touch points have built in Microban® antimicrobial product protection.

\*MICROBAN® and the MICROBAN® symbol are registered trademarks of the Microban Products Company, Huntersville, NC.

application . . . it's a no brainer.



*"While outfitting a damp area with shelving, we were able to upgrade our system; all 4 posts are now polymer and the bottom shelf is a Heavy Duty polymer as well . . . the units fit perfectly into our budget and provides long-term value."*



*"We've typically purchased standard wire shelving, but these days value is a must. Upgrading to MetroMax Q is the perfect balance between price and value. It's easy to clean and resists rust and corrosion, for a longer shelf life."*



Standard shelf with solid mat

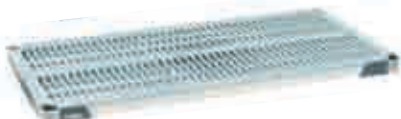

Standard shelf with grid mat



Heavy-duty shelf with solid mat



**Polymer Posts**

- Corrosion proof with built-in Microban antimicrobial product protection.
- Compatible for use with MetroMax i® and MetroMax Q shelves.
- Stationary posts include an adjustable leveling foot to compensate for uneven floors. Leveling foot can be adjusted 1" (25mm).



Nominal Height (in.) (mm)	Approx. Pkd. Wt. (lbs.) (kg)		Cat. No. Stationary Post with Leveling Foot	Cat. No. Mobile Post for Stem Caster
	(lbs.)	(kg)		
9	0.3	0.15	—	<b>MX9UP</b>
13	0.5	0.2	<b>MX13P</b>	<b>MX13UP</b>
27	0.9	0.4	<b>MX27P</b>	<b>MX27UP</b>
33	1.0	0.5	<b>MX33P</b>	<b>MX33UP</b>
54	1.6	0.7	<b>MX54P</b>	<b>MX54UP</b>
63	1.8	0.8	<b>MX63P</b>	<b>MX63UP</b>
74	2.2	1.0	<b>MX74P</b>	<b>MX74UP</b>
86	3.0	1.4	<b>MX86P</b>	<b>MX86UP</b>

(Special height cut posts are available. Consult your Metro representative.)

MetroMax i® Polymer Shelving — 9.20

**Standard Shelves**

- Part number includes shelf with removable mats and one bag of wedges.

Width (in.) (mm)	Nominal Length (in.) (mm)		Approx. Pkd. Wt. (lbs.) (kg)		Cat. No. Shelf with Grid Mat	Approx. Pkd. Wt. (lbs.) (kg)		Cat. No. Shelf with Solid Mat
	(in.)	(mm)	(lbs.)	(kg)		(lbs.)	(kg)	
18	457	24 610	8.7	4.0	<b>MX1824G</b>	12.7	5.8	<b>MX1824F</b>
18	457	30 760	10.5	4.7	<b>MX1830G</b>	14.5	6.6	<b>MX1830F</b>
18	457	36 914	12.2	5.5	<b>MX1836G</b>	17.2	7.8	<b>MX1836F</b>
18	457	42 1060	13.9	5.3	<b>MX1842G</b>	20.1	9.1	<b>MX1842F</b>
18	457	48 1220	15.7	7.1	<b>MX1848G</b>	23.1	10.5	<b>MX1848F</b>
18	457	54 1372	17.5	7.9	<b>MX1854G</b>	21.5	9.7	<b>MX1854F</b>
18	457	60 1524	19.2	8.7	<b>MX1860G</b>	23.2	10.5	<b>MX1860F</b>
18	457	72 1829	22.5	10.2	<b>MX1872G</b>	27.5	12.5	<b>MX1872F</b>
24	610	24 610	12.2	5.5	<b>MX2424G</b>	14.2	6.4	<b>MX2424F</b>
24	610	30 760	13.9	6.3	<b>MX2430G</b>	15.9	7.2	<b>MX2430F</b>
24	610	36 914	15.6	7.1	<b>MX2436G</b>	19.6	8.9	<b>MX2436F</b>
24	610	42 1060	17.5	7.9	<b>MX2442G</b>	21.5	9.8	<b>MX2442F</b>
24	610	48 1220	19.3	8.7	<b>MX2448G</b>	25.3	11.5	<b>MX2448F</b>
24	610	54 1372	21.0	9.5	<b>MX2454G</b>	25.0	11.3	<b>MX2454F</b>
24	610	60 1524	22.8	10.5	<b>MX2460G</b>	26.8	12.1	<b>MX2460F</b>
24	610	72 1829	26.0	11.8	<b>MX2472G</b>	31.0	14.1	<b>MX2472F</b>

Actual Dimensions: Width: Add 1/4" (6mm) to nominal size. Length: Subtract 1/4" (6mm) from nominal size.

**Heavy-Duty Dunnage Shelves**

- Weight capacity per shelf evenly distributed: 1,200 lbs. (544kg) on shelves up to and including 48" (1220mm) long; 900 lbs. (408kg) for shelves 60" (1524mm) long.

Width (in.) (mm)	Nominal Length (in.) (mm)		Approx. Pkd. Wt. (lbs.) (kg)		Cat. No. Shelf with Grid Mat	Approx. Pkd. Wt. (lbs.) (kg)		Cat. No. Shelf with Solid Mat
	(in.)	(mm)	(lbs.)	(kg)		(lbs.)	(kg)	
18	457	36 914	18	8.2	<b>MHP1836G</b>	22	10.0	<b>MHP1836F</b>
18	457	48 1220	22	10.0	<b>MHP1848G</b>	26	11.8	<b>MHP1848F</b>
18	457	60 1524	26	11.8	<b>MHP1860G</b>	30	13.6	<b>MHP1860F</b>
24	610	36 914	21	9.5	<b>MHP2436G</b>	25	11.3	<b>MHP2436F</b>
24	610	48 1220	27	12.2	<b>MHP2448G</b>	31	14.1	<b>MHP2448F</b>
24	610	60 1524	33	15.0	<b>MHP2460G</b>	37	16.8	<b>MHP2460F</b>

(Dunnage shelves are not recommended for use as part of an add-on unit with two posts.)



**MetroMax i® Replacement Wedges**

Bag of (4)  
Cat. No. **MX9985**  
MetroMax i® Wedges are not compatible with original MetroMax shelves and posts.



**Post Clamp**

Adds stability by joining posts of two separate units together. With it, each unit is supported by four posts and buttressed by the adjacent unit.  
Cat. No. **9994X**



**Foot Plate**

Use to add stability to the shelving unit or to bolt units to the floor.  
Cat. No. Zinc **9993Z**  
Cat. No. Stainless Steel **9993S**

✓ Indicates antimicrobial product.

Note: MetroMax i® shelves, posts, and wedges are not compatible with original MetroMax shelves and posts.

## MetroMax Q® Shelving — 9.21

### Standard Shelves

- Part number includes shelf with removable mats and one bag of wedges.

Width (in.)	(mm)	Nominal Length		Approx. Pkd. Wt.		Cat. No. Shelf with Cat. No.
		(in.)	(mm)	(lbs.)	(kg)	
18	457	24	610	6.2	2.8	<b>MQ1824G</b>
18	457	30	760	8.0	3.6	<b>MQ1830G</b>
18	457	36	914	9.7	4.4	<b>MQ1836G</b>
18	457	42	1060	11.4	5.2	<b>MQ1842G</b>
18	457	48	1220	13.2	6.0	<b>MQ1848G</b>
18	457	54	1372	15.0	6.8	<b>MQ1854G</b>
18	457	60	1524	16.7	7.6	<b>MQ1860G</b>
18	457	72	1829	20.0	9.1	<b>MQ1872G</b>
21	530	24	610	8.0	3.6	<b>MQ2124G</b>
21	530	30	760	9.7	4.4	<b>MQ2130G</b>
21	530	36	914	11.4	5.2	<b>MQ2136G</b>
21	530	42	1060	12.8	5.8	<b>MQ2142G</b>
21	530	48	1220	14.5	6.6	<b>MQ2148G</b>
21	530	54	1372	16.7	7.6	<b>MQ2154G</b>
21	530	60	1524	18.5	8.4	<b>MQ2160G</b>
21	530	72	1829	21.7	9.9	<b>MQ2172G</b>
24	610	24	610	9.7	4.4	<b>MQ2424G</b>
24	610	30	760	11.4	5.2	<b>MQ2430G</b>
24	610	36	914	13.1	6.0	<b>MQ2436G</b>
24	610	42	1060	14.1	6.4	<b>MQ2442G</b>
24	610	48	1220	15.8	7.1	<b>MQ2448G</b>
24	610	54	1372	18.5	8.4	<b>MQ2454G</b>
24	610	60	1524	20.3	9.2	<b>MQ2460G</b>
24	610	72	1829	23.5	10.7	<b>MQ2472G</b>

**Actual Dimensions:** Width: Add 3/8" (10mm) to nominal size.  
Length: Subtract 3/16" (5mm) from nominal size.



MetroMax Q® shelves that are part of the iQ system have different actual measurements than original MetroMax Q shelves and cannot be mixed on the same shelving units.



### Solid Mat Overlays

- Overlays snap onto the open grid mats to create a solid surface.
- Available for 21" (530mm) deep MetroMax Q shelves.
- For 18" (457mm) and 24" (610mm) deep solid shelves, please see Models MX\*\*\*\*F on previous page.

Fits Shelf		Approx. Pkd. Wt.		Cat. No.
(in.)	(mm)	(lbs.)	(kg)	
21x24	530x610	0.35	0.16	<b>Q2124SM</b>
21x30	530x760	0.45	0.20	<b>Q2130SM</b>
21x36	530x914	0.50	0.23	<b>Q2136SM</b>
21x42	530x1060	0.60	0.27	<b>Q2142SM</b>
21x48	530x1220	0.70	0.32	<b>Q2148SM</b>
21x54	530x1372	0.80	0.36	<b>Q2154SM</b>
21x60	530x1524	0.90	0.41	<b>Q2160SM</b>
21x72	530x1829	1.00	0.45	<b>Q2172SM</b>



### Posts

- Epoxy coated steel and polymer posts have Microban antimicrobial product protection.
- Stationary posts include an adjustable leveling foot to compensate for uneven floors. Leveling foot can be adjusted 1" (25mm).
- When mounting a shelving unit to a dolly base, stationary posts are used.

Nominal Height (in.)	(mm)	STEEL		POLYMER		Approx. Pkd. Wt. (lbs.)	(kg)	Cat. No. Stationary Post with Leveling Foot	Cat. No. Mobile Post for Stem Caster
		Approx. Pkd. Wt. (lbs.)	(kg)	Approx. Pkd. Wt. (lbs.)	(kg)				
9	228	0.3	0.15	—	—	—	—	—	<b>MX9UP</b>
13	370	1.0	0.5	<b>MQ13PE</b>	<b>MQ13UPE</b>	0.5	0.2	<b>MX13P</b>	<b>MX13UP</b>
27	685	2.0	0.9	<b>MQ27PE</b>	<b>MQ27UPE</b>	0.9	0.4	<b>MX27P</b>	<b>MX27UP</b>
33	875	2.5	1.1	<b>MQ33PE</b>	<b>MQ33UPE</b>	1.0	0.5	<b>MX33P</b>	<b>MX33UP</b>
54	1370	4.0	1.8	<b>MQ54PE</b>	<b>MQ54UPE</b>	1.6	0.7	<b>MX54P</b>	<b>MX54UP</b>
63	1585	4.5	2.0	<b>MQ63PE</b>	<b>MQ63UPE</b>	1.8	0.8	<b>MX63P</b>	<b>MX63UP</b>
70	1778	5.0	2.3	—	<b>MQ70UPE</b>	—	—	—	—
74	1890	5.5	2.5	<b>MQ74PE</b>	<b>MQ74UPE</b>	2.2	1.0	<b>MX74P</b>	<b>MX74UP</b>
86	2195	6.5	2.9	<b>MQ86PE</b>	<b>MQ86UPE</b>	3.0	1.4	<b>MX86P</b>	<b>MX86UP</b>

(Special height cut posts are available. Consult your Metro representative.)

✓ Indicates antimicrobial product.



MetroMax Q® Replacement Wedges

Bag of (4)  
Cat. No. **MQ9985**



MetroMax Q® Wedges are compatible with original MetroMax Q shelves and posts.

# Go mobile.

Add casters to any shelving unit to add versatility.

## MetroMax iQ Stem Casters — 9.25

For use with either MetroMax i polymer or MetroMax Q steel stem caster posts.

- Promotes easy cleaning. Casters allow shelving units to be moved easily for access to floors and walls.
- Efficient Transport: Create a cart to efficiently move supplies throughout a facility or campus.



5PCX



5PCBX



5MPX

## Polymer Stem Casters — 9.25

- Corrosion resistant performance: all-polymer horn, stainless steel axle and hardware, 5" (127mm) diameter polyurethane wheel, sleeve-style axle bearing, and an optional toe-operated brake mechanism.
- Models available with antimicrobial product protection built into the tread.
- Load rating of 300 lbs. (135kg) and a temperature range from -20° to 120° F (-29° to 49° C) [continuous].
- Bumpers included.

Wheel Tread	Type	Diameter (in.) (mm)	Width (in.) (mm)	Approx. Pkd. Wt. (lbs.) (kg)	Cat. No.	Cat. No. Antimicrobial
Polyurethane	Swivel	5 127	1¼ 32	2 .9	<b>5PCX</b>	<b>5PCXM</b>
Polyurethane	Brake	5 127	1¼ 32	2 .9	<b>5PCBX</b>	<b>5PCBXM</b>
Polyurethane	Rigid*	5 127	1¼ 32	2 .9	<b>5PCRX</b>	

**Note 1:** Optional tread guards (blue) may be ordered by adding "-TG" to the desired model number (eg. 5PC-TG, 5PCB-TG, 5PCR-TG).

**Note 2:** Stem casters are shipped with donut bumpers at no extra charge.

**Note 3:** Rigid casters are held in place by a connecting channel. When ordering, shelf width **must** be provided.

**Note 4:** Not suitable for cart wash and autoclave applications.

## Standard Stem Casters — 9.25

- Plated caster horns and hardware. Bumper included with each caster.
- Swivel, Swivel with Brakes, and Rigid Caster options available.

Type	Wheel Tread	Load Rating (lbs.) (kg)	Approx. Pkd. Wt. (lbs.) (kg)	Cat. No.
Stem/Swivel	Resilient	200 91	2¾ 1.2	<b>5MX</b>
Stem/Brake	Resilient	200 91	3 1.4	<b>5MBX</b>
Stem/Rigid*	Resilient	200 91	3¾ 1.7	<b>5MRX</b>
Stem/Swivel	Polyurethane	300 135	2¼ 1.0	<b>5MPX</b>
Stem/Brake	Polyurethane	300 135	2½ 1.1	<b>5MPBX</b>
Stem/Rigid*	Polyurethane	300 135	2¼ 1.0	<b>5MPRX</b>
Stem/Swivel	Resilient Donut	250 113	2½ 1.1	<b>5MDXA</b>
Stem/Brake	Resilient Donut	250 113	2½ 1.1	<b>5MDBXA</b>
Stem/Rigid*	Resilient Donut	250 113	2½ 1.1	<b>5MDRXA</b>

**Note:** Rigid casters are held in place by a connecting channel. When ordering, shelf width **must** be provided.

Rigid stem casters are often ordered two per unit for improved tracking and handling. Rigid caster channel are provided with each two rigid stem casters at no charge.



## Stainless Steel Cart-Washable Stem Casters — 9.25

- Stainless horn, axle, and stem with sealed bearings. Bumper included with each caster.

Type	Wheel Tread	Load Rating (lbs.) (kg)	Approx. Pkd. Wt. (lbs.) (kg)	Cat. No.
Stem/Swivel	Polyurethane	300 135	2⅞ 1.0	<b>5MPXGSA</b>
Stem/Brake	Polyurethane	300 135	2⅞ 1.0	<b>5MPBXGSA</b>
Stem/Rigid*	Polyurethane	300 135	2⅞ 1.0	<b>5MPRXGSA</b>

**Note:** Rigid casters are held in place by a connecting channel. When ordering, shelf width **must** be provided.

Replacement Bumper for MetroMax i® and MetroMax Q®  
Cat. No. **M9992DBX**

Indicates antimicrobial product.

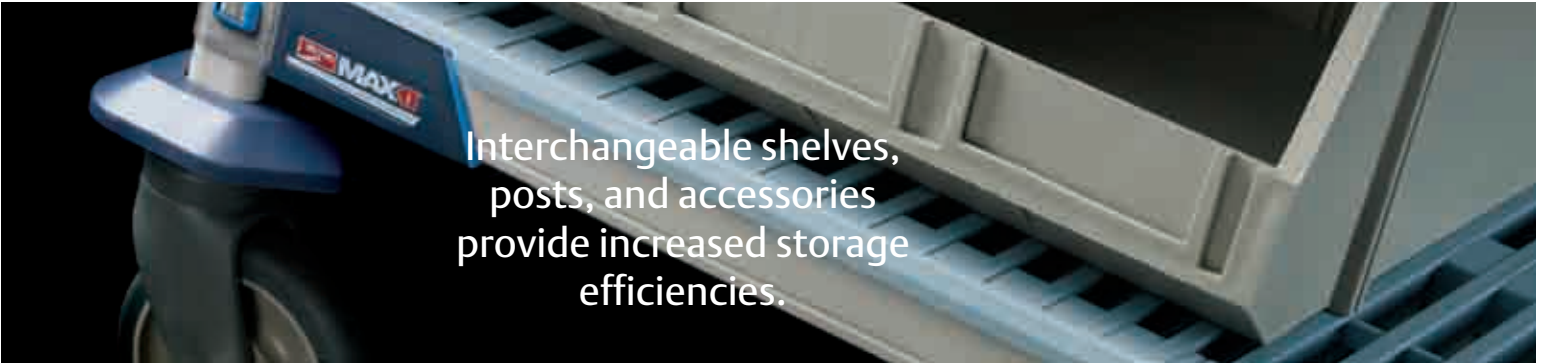

Interchangeable shelves, posts, and accessories provide increased storage efficiencies.

# Handle it.

Adding Stainless Steel handles to shelving puts you in control.

- Use handles on mobile units to improve maneuverability and ergonomics.
- Handles are compatible with MetroMax i® and MetroMax Q® units.
- Corrosion proof Type 304 stainless steel construction offers long lasting performance.



Tri-Lobal Adapters  
Included with handles.

Tri-Lobal Adapter  
Replacements  
Cat. No. **MTLA**  
Bag of 4 assemblies

MTLA adapters are designed to work with the new MetroMax iQ Storage System and are not compatible with original MetroMax.

Extended and Easy-Grip Handles are compatible with original MetroMax Q shelves.

## Extended Handle — 9.25

Fits Shelf Depth		Extension Depth (Post to Edge of Handle)		Approx. Pkd. Wt		i and Q Cat. No.
(in.)	(mm)	(in.)	(mm)	(lbs.)	(kg)	
18	457	4.5	113	2.5	1.1	<b>MEH18S</b>
21	530	4.5	113	2.6	1.2	<b>MEH21S</b>
24	610	4.5	113	2.8	1.3	<b>MEH24S</b>



## Easy-Grip Handle — 9.25

Fits Shelf Depth		Extension Depth (Post to Edge of Handle)		Approx. Pkd. Wt		i and Q Cat. No.
(in.)	(mm)	(in.)	(mm)	(lbs.)	(kg)	
18	457	6	151	2.5	1.1	<b>MERGH18S</b>
24	610	6	151	3.0	1.4	<b>MERGH24S</b>



## Swing-up Handle — 9.25

- Ideal for maneuvering heavier loads.

Fits Shelf Depth		Extension Depth (Post to Edge of Handle)		Approx. Pkd. Wt		i and Q Cat. No.
(in.)	(mm)	(in.)	(mm)	(lbs.)	(kg)	
24	610	17.75	447	4.5	2.0	<b>MSUH24S</b>





MetroMax i®  
with Open Grid Shelves



MetroMax i®  
with Solid Shelves

## MetroMax i® — Stem Caster Carts

- Corrosion proof shelves and posts; removable polymer mats.
- Standard Units consist of four shelves, MX63UP posts 63" (1600mm), wedge connectors and choice of resilient rubber or polyurethane casters.
- Weight Capacity of cart: models with resilient rubber casters: 600 lbs. (272kg); models with polyurethane casters: 900 lbs. (408kg)

### MetroMax i® Open Grid

Nominal Width/Length (in./mm)		Approx. Height (in./mm)		Approx. Pkd. Wt. (lbs./kg)		Cat. No. 2-Swivel 2-Brake Resilient Rubber Casters	Cat. No. 2-Swivel 2-Brake Polyurethane Casters
18x36	457x914	67 <sup>5</sup> / <sub>16</sub>	1710	74	33	<b>X336BGX3</b>	<b>X336EGX3</b>
18x48	457x1220	67 <sup>5</sup> / <sub>16</sub>	1710	86	38	<b>X356BGX3</b>	<b>X356EGX3</b>
18x60	457x1524	67 <sup>5</sup> / <sub>16</sub>	1710	98	44	<b>X366BGX3</b>	<b>X366EGX3</b>
24x36	610x914	67 <sup>5</sup> / <sub>16</sub>	1710	82	37	<b>X536BGX3</b>	<b>X536EGX3</b>
24x48	610x1220	67 <sup>5</sup> / <sub>16</sub>	1710	98	44	<b>X556BGX3</b>	<b>X556EGX3</b>
24x60	610x1524	67 <sup>5</sup> / <sub>16</sub>	1710	114	51	<b>X566BGX3</b>	<b>X566EGX3</b>

### MetroMax i® Solid Shelves

Approx. Pkd. Wt. (lbs./kg)		Cat. No. 2-Swivel 2-Brake Polyurethane Casters
94 42	<b>X336EFX3</b>	
106 48	<b>X356EFX3</b>	
118 53	<b>X366EFX3</b>	
102 46	<b>X536EFX3</b>	
118 53	<b>X556EFX3</b>	
134 60	<b>X566EFX3</b>	

## MetroMax Q® — Stem Caster Cart, Open Grid Shelves

- Quick adjust shelves with removable polymer shelf mats.
- Standard Units consist of four open grid shelves, MQ63UPE posts 63" (1600mm), wedge connectors, and choice of resilient rubber or polyurethane casters.
- Weight Capacity of cart: models with resilient rubber casters: 600 lbs. (272kg); models with polyurethane casters: 900 lbs. (408kg)



MetroMax Q®  
with Open Grid Shelves

Nominal Width/Length (in./mm)		Approx. Height (in./mm)		Approx. Pkd. Wt. (lbs./kg)		Cat. No. 2-Swivel 2-Brake Resilient Rubber Casters	Cat. No. 2-Swivel 2-Brake Polyurethane Casters
18x36	457x914	67 <sup>5</sup> / <sub>16</sub>	1710	68	31	<b>Q336BG3</b>	<b>Q336EG3</b>
18x48	457x1220	67 <sup>5</sup> / <sub>16</sub>	1710	84	38	<b>Q356BG3</b>	<b>Q356EG3</b>
18x60	457x1524	67 <sup>5</sup> / <sub>16</sub>	1710	100	45	<b>Q366BG3</b>	<b>Q366EG3</b>
21x36	530x914	67 <sup>5</sup> / <sub>16</sub>	1710	74	34	<b>Q436BG3</b>	<b>Q436EG3</b>
21x48	530x1220	67 <sup>5</sup> / <sub>16</sub>	1710	90	41	<b>Q456BG3</b>	<b>Q456EG3</b>
21x60	530x1524	67 <sup>5</sup> / <sub>16</sub>	1710	106	48	<b>Q466BG3</b>	<b>Q466EG3</b>
24x36	610x914	67 <sup>5</sup> / <sub>16</sub>	1710	80	36	<b>Q536BG3</b>	<b>Q536EG3</b>
24x48	610x1220	67 <sup>5</sup> / <sub>16</sub>	1710	96	44	<b>Q556BG3</b>	<b>Q556EG3</b>
24x60	610x1524	67 <sup>5</sup> / <sub>16</sub>	1710	112	51	<b>Q566BG3</b>	<b>Q566EG3</b>

## Stem Caster Carts with Solid Bottom MetroMax i® Shelves

- 5-tier models with Microban® antimicrobial product protection.
- Standard Units consist of 5 shelves (4 open grid, 1 MetroMax i solid), 74" (1880mm) posts, wedge connectors, and polyurethane casters.
- Weight Capacity of cart: models with resilient rubber casters: 600 lbs. (272kg); models with polyurethane casters: 900 lbs. (408kg)



MetroMax i®  
with a Solid Bottom Shelf

Nominal Width/Length (in./mm)		Approx. Height (in./mm)		Approx. Pkd. Wt. (lbs./kg)		i 2-Swivel 2-Brake Polyurethane Casters Cat. No.	Q 2-Swivel 2-Brake Polyurethane Casters Cat. No.
18x36	457x914	79 <sup>5</sup> / <sub>16</sub>	2015	82	37	<b>5X337EGX3</b>	<b>5Q337EG3</b>
18x48	457x1220	79 <sup>5</sup> / <sub>16</sub>	2015	109	49	<b>5X357EGX3</b>	<b>5Q357EG3</b>
18x60	457x1524	79 <sup>5</sup> / <sub>16</sub>	2015	121	55	<b>5X367EGX3</b>	<b>5Q367EG3</b>
24x36	610x914	79 <sup>5</sup> / <sub>16</sub>	2015	102	46	<b>5X537EGX3</b>	<b>5Q537EG3</b>
24x48	610x1220	79 <sup>5</sup> / <sub>16</sub>	2015	123	56	<b>5X557EGX3</b>	<b>5Q557EG3</b>
24x60	610x1524	79 <sup>5</sup> / <sub>16</sub>	2015	141	63	<b>5X567EGX3</b>	<b>5Q567EG3</b>

Indicates antimicrobial product.

# Push ahead.

Give yourself the versatility you need with Metro Utility Carts.

## Utility Carts

- Can be used in a variety of unique transport applications.
- Durable materials, ergonomic handles, and premium casters promote long life and ease of use.
- Microban product protection built into the shelf mats, frames, and posts.
- Easier to clean with removable shelf mats.

## MetroMax i® Utility Carts

- Corrosion proof shelves, posts, and Type 304 stainless steel handle.
- Corrosion resistant 5PCX casters with 5" (127mm) polyurethane wheels, polymer horns, and stainless steel axles.
- 39 1/4" (997mm) tall. Weight capacity of cart: 900 lbs. (408kg) evenly distributed.

Nominal Width/Length (in.) (mm)		Actual Width/Length (in.) (mm)		Description	Approx. Pkd. Wt. (lbs.) (kg)		Cat. No.
18x30	457x760	20 <sup>5</sup> / <sub>16</sub> x 34 <sup>1</sup> / <sub>2</sub>	516 x 876		2-shelf	35.5	
24x36	610x914	26 <sup>5</sup> / <sub>16</sub> x 40 <sup>1</sup> / <sub>2</sub>	668 x 1029	2-shelf	46.0	20.5	<b>MXUC2436G-25</b>
18x30	457x760	20 <sup>5</sup> / <sub>16</sub> x 34 <sup>1</sup> / <sub>2</sub>	516 x 876	3-shelf	46.0	20.5	<b>MXUC1830G-35</b>
24x36	610x914	26 <sup>5</sup> / <sub>16</sub> x 40 <sup>1</sup> / <sub>2</sub>	668 x 1029	3-shelf	61.5	27.5	<b>MXUC2436G-35</b>



## MetroMax Q® Utility Carts

- Quick adjust corrosion resistant shelves and posts.
- Corrosion proof Type 304 stainless steel handle.
- Includes four 5MPX casters with 5" (127mm) polyurethane wheels.
- 39 1/4" (997mm) tall. Weight capacity of cart: 900 lbs. (408kg) evenly distributed.

Nominal Width/Length (in.) (mm)		Actual Width/Length (in.) (mm)		Description	Approx. Pkd. Wt. (lbs.) (kg)		Cat. No.
18x30	457x760	20 <sup>5</sup> / <sub>16</sub> x 34 <sup>1</sup> / <sub>2</sub>	516 x 876		2-shelf	35.5	
24x36	610x914	26 <sup>5</sup> / <sub>16</sub> x 40 <sup>1</sup> / <sub>2</sub>	668 x 1029	2-shelf	46.0	20.5	<b>MQUC2436G-25</b>
18x30	457x760	20 <sup>5</sup> / <sub>16</sub> x 34 <sup>1</sup> / <sub>2</sub>	516 x 876	3-shelf	46.0	20.5	<b>MQUC1830G-35</b>
24x36	610x914	26 <sup>5</sup> / <sub>16</sub> x 40 <sup>1</sup> / <sub>2</sub>	668 x 1029	3-shelf	61.5	27.5	<b>MQUC2436G-35</b>



## Helpful Hints

- Configure a cart to your exact needs using a combination of MetroMax i® and Q™ shelves and posts.
- Consider MetroMax i solid shelves when spill containment is required or to protect supplies from dirt during transport.
- A typical utility cart will be configured using 27" (685mm) or 33" (875mm) stem caster posts with 5" (127mm) casters.



Solid bottom shelf and 5PCX/5PCBX casters pictured

**Shelves and posts: pages 14-15   Casters: page 16   Handles: page 17**

Indicates antimicrobial product.



Add-On units with "S" hooks can only be attached to shelves supported by two or more posts.

MetroMax i® Shelving Starter and Add-On Units

- Save time and money by eliminating adjacent posts and replacing with "S" hooks.
- Starter Units consist of four posts and indicated number of MetroMax i shelves.
- Add-On Units consist of two posts, indicated number of shelves, and two "S" Hooks per shelf, for attaching shelf to adjacent unit. To attach shelves at right angles, Intermediate "S" Hook Kits must be ordered separately.

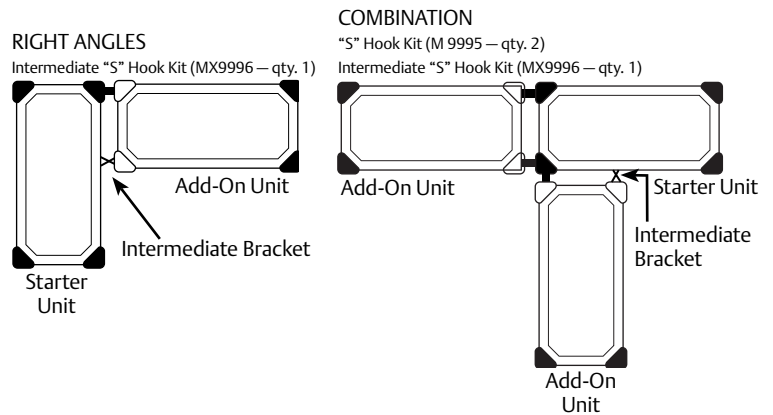
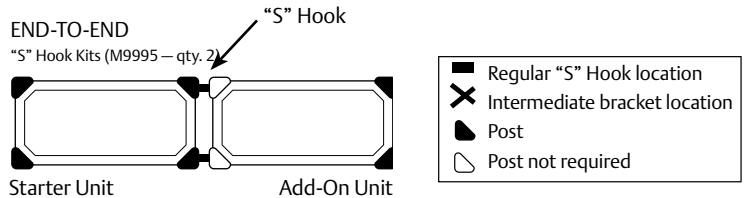

"S" Hook  
Cat. No. **M9995**

"S" Hook

Add on shelving to existing units using two posts instead of four. Kit includes one "S" hook and one corner collar plug. Two kits required per storage level when configuring units end-to-end.

Cat. No. **M9995**



Intermediate "S" Hook Kit  
Cat. No. **MX9996**

MetroMax i® Intermediate "S" Hook Kit

Required when joining units at right angles with open corner and no post. Intermediate bracket connects a shelf corner to the front beam of the adjoining shelf. Kit includes one intermediate bracket, two "S" Hooks, and two corner collar plugs. See illustration for quantity required per level.  
Cat. No. **MX9996**



Collar plug fits MetroMax i

Shelving Starter and Add-On Units – Easy Order Guide

**5 Shelves**  
74" (1880mm) Posts

	Cat. No.	18" (457mm) Wide		24" (610mm) Wide	
		Starter	Add-On	Starter	Add-On
<b>24" (610mm) Long</b>	<b>5X317GX3</b>	<b>5AX317GX3</b>	<b>5X517GX3</b>	<b>5AX517GX3</b>	<b>5X517GX3</b>
Wt. lbs. (kg)	60 (27)	55 (25)	65 (29)	60 (27)	60 (27)
<b>30" (760mm) Long</b>	<b>5X327GX3</b>	<b>5AX327GX3</b>	<b>5X527GX3</b>	<b>5AX527GX3</b>	<b>5X527GX3</b>
Wt. lbs. (kg)	65 (29)	60 (27)	80 (36)	75 (34)	75 (34)
<b>36" (914mm) Long</b>	<b>5X337GX3</b>	<b>5AX337GX3</b>	<b>5X537GX3</b>	<b>5AX537GX3</b>	<b>5X537GX3</b>
Wt. lbs. (kg)	70 (32)	65 (29)	85 (39)	80 (36)	80 (36)
<b>42" (1066mm) Long</b>	<b>5X347GX3</b>	<b>5AX347GX3</b>	<b>5X547GX3</b>	<b>5AX547GX3</b>	<b>5X547GX3</b>
Wt. lbs. (kg)	80 (36)	75 (34)	95 (43)	90 (41)	90 (41)
<b>48" (1219mm) Long</b>	<b>5X357GX3</b>	<b>5AX357GX3</b>	<b>5X557GX3</b>	<b>5AX557GX3</b>	<b>5X557GX3</b>
Wt. lbs. (kg)	90 (41)	85 (39)	105 (48)	100 (45)	100 (45)
<b>60" (1524mm) Long</b>	<b>5X367GX3</b>	<b>5AX367GX3</b>	<b>5X567GX3</b>	<b>5AX567GX3</b>	<b>5X567GX3</b>
Wt. lbs. (kg)	110 (50)	105 (48)	115 (52)	110 (50)	110 (50)
<b>72" (1825mm) Long</b>	<b>5X377GX3</b>	<b>5AX377GX3</b>	<b>5X577GX3</b>	<b>5AX577GX3</b>	<b>5X577GX3</b>
Wt. lbs. (kg)	125 (57)	120 (54)	145 (66)	140 (64)	140 (64)

Note: "Right Angle" Add-On Units require one additional Intermediate "S" Hook kit per shelf level.

✓ Indicates antimicrobial product.

## MetroMax Q® Shelving Starter and Add-On Units

- Save time and money by eliminating adjacent posts and replacing with “S” hooks.
- Starter Units consist of four posts and indicated number of MetroMax Q shelves.
- Add-On Units consist of two posts, indicated number of shelves, and two “S” Hooks per shelf, for attaching shelf to adjacent unit. To attach shelves at right angles, Intermediate “S” Hook Kits must be ordered separately.

### END-TO-END

“S” Hook Kits (M9995 – qty. 2)

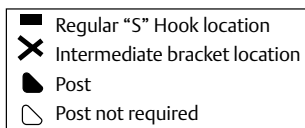
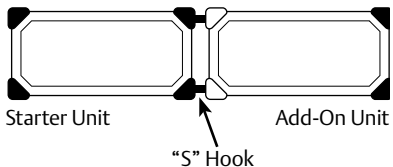

### RIGHT ANGLES

Intermediate “S” Hook Kit (Q9995Z – qty. 1)

“S” Hook Kits (M9995 – qty. 1)

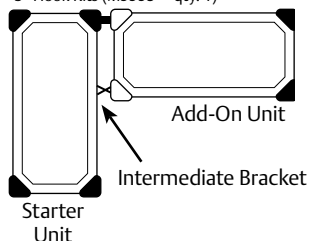

### COMBINATION

“S” Hook Kit (M 9995 – qty. 3)

Intermediate “S” Hook Kit (MX9996 – qty. 1)

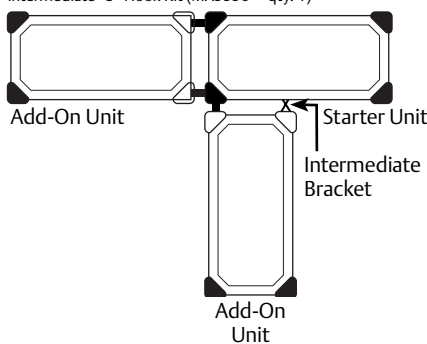

Add-On units with “S” hooks can only be attached to shelves supported by two or more posts.

### “S” Hook

Add on shelving using two posts instead of four. Includes one “S” hook. Two kits required per level when configuring units end-to-end. Cat. No. **M9995**

**Note:** Collar/hole plug is designed for use with MetroMax i shelves only.



“S” Hook  
Cat. No. **M9995**

### MetroMax Q® Intermediate “S” Hook Kit

Use when configuring MetroMax Q Starter and Add-On Units at right angles.

Cat. No. **Q9995Z**



Intermediate “S”  
Hook Kit  
Cat. No. **Q9995Z**

## Shelving Starter and Add-On Units – Easy Order Guide

### 5 Shelves

74" (1880mm) Posts

	Cat. No.	18" (457mm) Wide		21" (530mm) Wide		24" (610mm) Wide	
		Starter	Add-On	Starter	Add-On	Starter	Add-On
24" (610mm)		<b>5Q317G3</b>	<b>5AQ317G3</b>	<b>5Q417G3</b>	<b>5AQ417G3</b>	<b>5Q517G3</b>	<b>5AQ517G3</b>
Long	Wt. lbs. (kg)	50.4 (23)	40.4 (18)	56.4 (26)	46.4 (21)	56.4 (26)	46.4 (21)
30" (760mm)		<b>5Q327G3</b>	<b>5AQ327G3</b>	<b>5Q427G3</b>	<b>5AQ427G3</b>	<b>5Q527G3</b>	<b>5AQ527G3</b>
Long	Wt. lbs. (kg)	57.9 (26)	47.9 (22)	63.1 (29)	53.1 (24)	66.4 (30)	56.4 (26)
36" (914mm)		<b>5Q337G3</b>	<b>5AQ337G3</b>	<b>5Q437G3</b>	<b>5AQ437G3</b>	<b>5Q537G3</b>	<b>5AQ537G3</b>
Long	Wt. lbs. (kg)	65.4 (30)	55.4 (25)	70.9 (32)	60.9 (28)	76.4 (35)	65.4 (30)
42" (1066mm)		<b>5Q347G3</b>	<b>5AQ347G3</b>	<b>5Q447G3</b>	<b>5AQ447G3</b>	<b>5Q547G3</b>	<b>5AQ547G3</b>
Long	Wt. lbs. (kg)	72.9 (33)	62.9 (29)	82.1 (37)	72.1 (33)	86.4 (39)	78.4 (36)
48" (1219mm)		<b>5Q357G3</b>	<b>5AQ357G3</b>	<b>5Q457G3</b>	<b>5AQ457G3</b>	<b>5Q557G3</b>	<b>5AQ557G3</b>
Long	Wt. lbs. (kg)	80.4 (36)	70.4 (32)	89.4 (41)	79.4 (36)	96.4 (44)	86.4 (39)
60" (1524mm)		<b>5Q367G3</b>	<b>5AQ367G3</b>	<b>5Q467G3</b>	<b>5AQ467G3</b>	<b>5Q567G3</b>	<b>5AQ567G3</b>
Long	Wt. lbs. (kg)	95.4 (43)	85.4 (39)	106.4 (48)	96.4 (44)	116.4 (53)	106.4 (48)
72" (1825mm)		<b>5Q377G3</b>	<b>5AQ377G3</b>	<b>5Q477G3</b>	<b>5AQ477G3</b>	<b>5Q577G3</b>	<b>5AQ577G3</b>
Long	Wt. lbs. (kg)	110.4 (50)	100.4 (46)	121.4 (55)	111.4 (51)	136.4 (62)	126.4 (57)

✓ Indicates antimicrobial product.



# Organize.

## Organize supplies to improve operational efficiencies.

- Well-organized storage results in fewer expired supplies and less waste.
- Innovative shelf and accessory designs have smooth surfaces that protect vacuum sealed and other packaged items from damage.
- Flexible compartments help sort supplies for faster access and maximize the use of storage space.

A Dividers B Ledges C Enclosure Panels D Metro Totes E Metro Bins

## Flexible Compartments

**Dividers and Ledges** can be used to create flexible compartments that most efficiently use available storage space. When combined with open grid shelves this minimizes dust accumulation.

**Bins** offer removable compartmentalized storage for easy access or as part of an exchange system. See page 60 for Bin options.

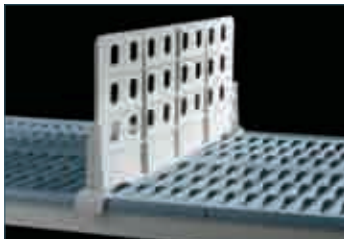
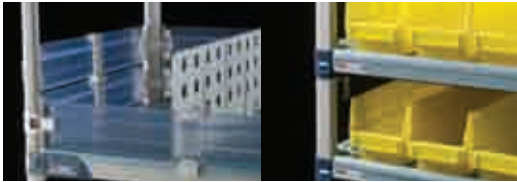

### 8" (203mm) Shelf Dividers — Standard Duty — 9.25

- i and Q versions available.
- Use to create organized compartments or to simply separate shelf contents.
- Easily repositioned on grid and solid shelves.
- Corrosion proof.

Nominal Length (in.) (mm)	Approx. Pkd. Wt. (lbs.) (kg)	i Cat. No.	Q Cat. No.
18 457	1.3 0.6	<b>MXD18-8</b>	<b>MQD18-8</b>
24 610	1.6 0.7	<b>MXD24-8</b>	<b>MQD24-8</b>

\*Note: Can be retrofitted to original MetroMax and MetroMax Q.

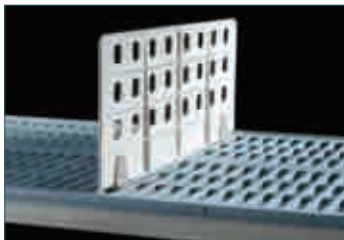

### Universal 8" (203mm) Shelf Dividers — Light Duty, for open grid shelves — 9.25

- For use with MetroMax i and Q grid shelves, Super Erecta wire shelves, and Super Adjustable wire shelves.
- Maximum flexibility: Can be repositioned along the entire shelf.
- Each divider includes a panel and two clips to connect to any open grid or wire shelf. Does not attach to solid shelves.
- Corrosion proof.

Nominal Length (in.) (mm)	Fits Shelf Depth	Approx. Pkd. Wt. (lbs.) (kg)	i and Q Cat. No.
18 457	18", 21" (457, 530mm)	1.3 0.6	<b>MUD18-8</b>
24 610	24" (610mm)	1.6 0.7	<b>MUD24-8</b>

\*Note: Can be retrofitted to original MetroMax and MetroMax Q.  
Additional clips: Cat. No **DCLIP**, 2 per bag, List Price 6.20

### Shelf-to-Shelf Dividers — 9.25

- Full height dividers efficiently compartmentalize the space between two shelves.
- Smooth surfaces protect packaged items from damage.
- Corrosion proof.
- Compatible with MetroMax i and Q open grid shelves, Super Erecta wire shelves, and Super Adjustable wire shelves. Does not work with solid shelves.

Fits Shelf Depth		Nominal Height		Approx. Pkd. Wt.		i and Q
(in.)	(mm)	(in.)	(mm)	(lbs.)	(kg)	Cat. No.
18, 21	457, 530	16	406	2.3	1.0	MD18-16
18, 21	457, 530	20	508	2.5	1.1	MD18-20
18, 21	457, 530	24	610	3.8	1.7	MD18-24
24	610	16	406	2.8	1.2	MD24-16
24	610	20	508	3.0	1.3	MD24-20
24	610	24	610	4.4	2.0	MD24-24

\*Note: Can be retrofitted to original MetroMax and MetroMax Q shelves.  
 \*Note: -16 parts have three panels, -20 parts have four panels, -24 parts have five panels.



### 2" (51mm) Stackable Shelf Ledges — 9.25

- Prevent items from falling off shelves.
- Snap on and off quickly. Easily stacked to contain larger items.
- Corrosion proof.
- Ships assembled.

Nominal Length		Type	Approx. Pkd. Wt.		i	Q
(in.)	(mm)		(lbs.)	(kg)	Cat. No.	Cat. No.
18	457	Side	0.50	0.2	MXLS18-2S	MQLS18-2S
21	530	Side	0.50	0.2	—	MQLS21-2S
24	610	Side	0.50	0.2	MXLS24-2S	MQLS24-2S
24	610	Back	0.50	0.2	MXL24-2S	MQL24-2S
30	760	Back	0.75	0.3	MXL30-2S	MQL30-2S
36	914	Back	1.00	0.4	MXL36-2S	MQL36-2S
42	1066	Back	1.25	0.6	MXL42-2S	MQL42-2S
48	1219	Back	1.25	0.6	MXL48-2S	MQL48-2S
54	1370	Back	1.50	0.7	MXL54-2S	MQL54-2S
60	1524	Back	1.75	0.8	MXL60-2S	MQL60-2S
72	1829	Back	2.00	0.9	MXL72-2S	MQL72-2S

\*Note: MetroMax i wire ledges can be retrofitted to original MetroMax.  
 \*Note: MetroMax Q wire ledges (MQ-) cannot be retrofitted to original MetroMax Q.



### 4" (102mm) Solid Clear Stackable Shelf Ledges — 9.26

- Solid design helps contain small items.
- Clear plastic allows light penetration and visible access to supplies.
- Corrosion proof.
- Ships assembled.

Nominal Length		Type	Approx. Pkd. Wt.		i	Q
(in.)	(mm)		(lbs.)	(kg)	Cat. No.	Cat. No.
18	457	Side	0.50	0.2	MXLS18-4P	MQLS18-4P
21	530	Side	0.50	0.2	—	MQLS21-4P
24	610	Side	0.50	0.2	MXLS24-4P	MQLS24-4P
24	610	Back	0.50	0.2	MXL24-4P	MQL24-4P
30	760	Back	0.75	0.3	MXL30-4P	MQL30-4P
36	914	Back	1.00	0.4	MXL36-4P	MQL36-4P
42	1066	Back	1.25	0.6	MXL42-4P	MQL42-4P
48	1219	Back	1.25	0.6	MXL48-4P	MQL48-4P
54	1370	Back	1.50	0.7	MXL54-4P	MQL54-4P
60	1524	Back	1.75	0.8	MXL60-4P	MQL60-4P

\*Note: MetroMax i wire ledges can be retrofitted to original MetroMax.  
 \*Note: MetroMax Q wire ledges (MQ-) cannot be retrofitted to original MetroMax Q.  
 Note: Not suitable for cart-wash applications.





# Contain it.

Efficiently enclose and contain with Enclosure Panels.

Enclosure Panels — 9.25

- An efficient way of enclosing the sides and back of all shelves in a unit to contain stored contents.
- Slot opening: 3" W x 3<sup>7</sup>/<sub>8</sub>" H.
- Designed to work with MetroMax i® and MetroMax Q® shelves. Mounting clips included.

Use shelf to shelf dividers with enclosure panels to create full height compartments to organize bulky, hard-to-handle supplies.

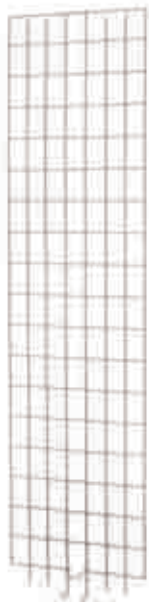

Enclosure Panel

Actual Width/Height		Post Height		For use with Shelf Width		Approx. Pkd. Wt.		i and Q Cat. No.
(in.)	(mm)	(in.)	(mm)	(in.)	(mm)	(lbs.)	(kg)	
12 <sup>3</sup> / <sub>8</sub> x 51 <sup>1</sup> / <sub>4</sub>	315 x 1300	54	1370	18	457	6 <sup>1</sup> / <sub>4</sub>	2.8	<b>MEP35E</b>
12 <sup>3</sup> / <sub>8</sub> x 59 <sup>1</sup> / <sub>4</sub>	315 x 1505	63	1600	18	457	7	3.2	<b>MEP36E</b>
12 <sup>3</sup> / <sub>8</sub> x 71 <sup>1</sup> / <sub>4</sub>	315 x 1810	74	1880	18	457	8 <sup>3</sup> / <sub>4</sub>	4.0	<b>MEP37E</b>
18 <sup>3</sup> / <sub>8</sub> x 51 <sup>1</sup> / <sub>4</sub>	467 x 1300	54	1370	21, 24	530, 610	9	4.1	<b>MEP55E</b>
18 <sup>3</sup> / <sub>8</sub> x 59 <sup>1</sup> / <sub>4</sub>	467 x 1505	63	1600	21, 24	530, 610	10 <sup>1</sup> / <sub>4</sub>	4.7	<b>MEP56E</b>
18 <sup>3</sup> / <sub>8</sub> x 71 <sup>1</sup> / <sub>4</sub>	467 x 1810	74	1880	21, 24	530, 610	11 <sup>3</sup> / <sub>4</sub>	5.3	<b>MEP57E</b>

\*Note: Can be retrofitted to original MetroMax and MetroMax Q shelving.

Panels Required to Enclose Both Ends of the Shelving Unit or Cart

Post Height	Shelf Width		
	18" (457mm)	21" (530mm)	24" (610mm)
54" (1370mm)	(2) MEP35E	(2) MEP55E	(2) MEP55E
63" (1600mm)	(2) MEP36E	(2) MEP56E	(2) MEP56E
74" (1880mm)	(2) MEP37E	(2) MEP57E	(2) MEP57E

Configuration Notes

- Handles and enclosure panels** can be used on the same end of the cart. Please note the following details: 21" (530mm) wide units: use the 12<sup>3</sup>/<sub>8</sub>" (315mm) wide panel on the same end as the handle.
- Top-Track:** When using on the ends of a Top-Track mobile unit the enclosure panel must be mounted so that it does not interfere with the overhead tracks. Mobile posts on Top-Track are 74" (1880mm). The standard enclosure panel for 74"(1880mm) posts can be used but must be mounted in a lower position on the unit. As an alternative, the standard panels for a 63" (1600mm) post can be used.

Panels Required to Enclose Back of Shelving Unit or Cart

Post Height	Shelf Length						
	30" (760mm)	36" (914mm)	42" (1066mm)	48" (1219mm)	54" (1370mm)	60" (1524mm)	72" (1825mm)
54" (1370mm)	(2) MEP35E	(1) MEP35E (1) MEP55E	(2) MEP55E	(2) MEP35E (1) MEP55E	(1) MEP35E (2) MEP55E	(3) MEP55E	(1) MEP35E (3) MEP55E
63" (1600mm)	(2) MEP36E	(1) MEP36E (1) MEP56E	(2) MEP56E	(2) MEP36E (1) MEP56E	(1) MEP36E (2) MEP56E	(3) MEP56E	(1) MEP36E (3) MEP56E
74" (1880mm)	(2) MEP37E	(1) MEP37E (1) MEP57E	(2) MEP57E	(2) MEP37E (1) MEP57E	(1) MEP37E (2) MEP57E	(3) MEP57E	(1) MEP37E (3) MEP57E



MetroMax i®  
Mounting Clip  
Replacements  
Cat. No. **RPMX3-RODTAB**



MetroMax Q® Mounting  
and Bottom Adapter  
Clip Replacements  
Cat. No. **RPMQ3-RODTAB**

✓ Indicates antimicrobial product.



### Label Holders

- Plastic holders snap onto shelf edge to accommodate 1" (25mm) tall adhesive label. Label not included.
- i and Q versions available.
- Optional label holder covers exist for MetroMax Q models. Cover snaps onto the label holder to hold a non-adhesive label in place or to protect any label from dirt and moisture.



### MetroMax i® — 9.25

Height: 1" (25mm)

Actual Length (in.) (mm)		Fits Shelf Length (in.) (mm)		Approx. Pkd. Wt. (lbs.) (kg)		Cat. No. Label Holder
4 1/2	114	All		0.03	0.01	9989PX
11 9/32	285	24	610	0.14	0.06	9989X1
17 9/32	438	30	760	0.24	0.10	9989X2
23 9/32	590	36	914	0.30	0.13	9989X3
29 9/32	742	42	1060	0.35	0.15	9989X4
35 9/32	895	48	1219	0.40	0.18	9989X5
41 9/32	1047	54	1370	0.45	0.20	9989X6



MetroMax i® Label Holder

### MetroMax Q® — 9.25

Height: 1 1/2" (37mm)

Actual Length (in.) (mm)		Fits Shelf Length (in.) (mm)		Approx. Pkd. Wt. (lbs.) (kg)		Cat. No. Label Holder	Cat. No. Label Holder Cover
4	102	All		0.03	0.01	Q04LH	Q04LHC
17 5/8	448	24	610	0.14	0.06	Q24LH	Q24LHC
23 5/8	600	30	760	0.24	0.10	Q30LH	Q30LHC
29 5/8	752	36	914	0.30	0.13	Q36LH	Q36LHC
35 5/8	905	42	1060	0.35	0.15	Q42LH	Q42LHC
41 5/8	1057	48	1219	0.40	0.18	Q48LH	Q48LHC
47 5/8	1210	54	1370	0.45	0.20	Q54LH	Q54LHC
53 5/8	1362	60	1524	0.50	0.22	Q60LH	Q60LHC
59 5/8	1514	66	1676	0.60	0.27	Q72LH	—



MetroMax Q® Label Holder

### Color Shelf Markers — 9.25

- Attach easily to shelf for content identification.
- Use to assign color coding to individual shelf levels, shelving units, carts, or storage areas.
- i and Q versions available.
- 6" (152mm) length.



MetroMax i® Color Shelf Marker

Shelf Marker Color	Approx. Pkd. Wt. (lbs.) (kg)		i	Q
	(lbs.)	(kg)	Cat. No.	Cat. No.
Blue	0.05	0.02	CSM6-BX	CSM6-BQ
Green	0.05	0.02	CSM6-GX	CSM6-GQ
Red	0.05	0.02	CSM6-RX	CSM6-RQ
Tan	0.05	0.02	CSM6-TX	CSM6-TQ
White	0.05	0.02	CSM6-WX	CSM6-WQ
Yellow	0.05	0.02	CSM6-YX	CSM6-YQ
Gray	0.05	0.02	CSM6-GRX	CSM6-GRQ

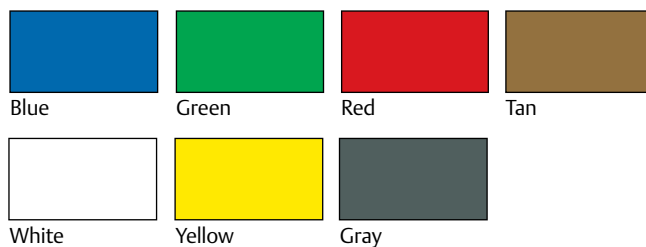

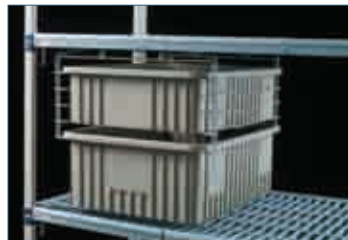

**Super Slide** — 9.25

- Designed to fit a 24" (610mm) wide shelf.
- Easily attaches to the shelf frame (under the mats) and is sized to hold 3", 5", 6", and 8" (76, 127, 152, 203mm) tall tote boxes (sold separately).
- MetroMax i® and Q models available.
- Corrosion resistant taupe epoxy finish with Microban antimicrobial product protection.

Width		Length		Height		Approx. Pkd. Wt.		i	Q
(in.)	(mm)	(in.)	(mm)	(in.)	(mm)	(lbs.)	(kg)	Cat. No.	Cat. No.
20 <sup>3</sup> / <sub>8</sub>	520	21 <sup>5</sup> / <sub>8</sub>	550	10 <sup>1</sup> / <sub>4</sub>	260	5 <sup>1</sup> / <sub>4</sub>	2	<b>MXSS2E</b>	<b>MQSS2E</b>



**Undershelf Slide** — 9.25

- Available for MetroMax i only.
- Easily attaches to the MetroMax i® shelf frame to allow you create a more versatile storage system.
- Tote box (sold separately) can serve as a drawer on mobile units or utility carts.
- Aluminum finish.

Fits Shelf Width		Length		Approx. Pkd. Wt.		i
(in.)	(mm)	(in.)	(mm)	(lbs.)	(kg)	Cat. No.
18	457	22 <sup>3</sup> / <sub>4</sub>	578	3 <sup>1</sup> / <sub>4</sub>	1.5	<b>BSD2218XA</b>
24	610	17 <sup>3</sup> / <sub>4</sub>	451	3 <sup>3</sup> / <sub>4</sub>	1.7	<b>BSD2224XB</b>

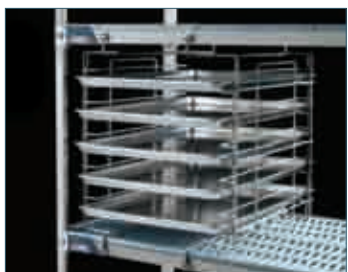

**Adjustable Slides** — 9.25

- Slides can be adjusted left to right to accommodate a variety of pan, tray, and container sizes.
- MetroMax i® and Q models available.
- Corrosion resistant taupe epoxy finish with Microban antimicrobial product protection.
- Shelves must be spaced 20" (508mm) apart.
- Can be used in conjunction with 20" (508mm) tall shelf-to-shelf dividers.

Fits Shelf Width		Type	Approx. Pkd. Wt.		i	Q
(in.)	(mm)		(lbs.)	(kg)	Cat. No.	Cat. No.
18	457	Adjustable	10 <sup>3</sup> / <sub>4</sub>	5	<b>MX18SE</b>	<b>MQ18SE</b>
24	610	Adjustable	12 <sup>3</sup> / <sub>4</sub>	6	<b>MX24SE</b>	<b>MQ24SE</b>



**Can Rack System** — 9.25

- Front loading, front dispensing can rack holds eight #10 cans or twelve #5 cans.
- Tough, corrosion resistant taupe epoxy finish with Microban antimicrobial product protection.
- Designed to fit a 24" (610mm) wide shelf.
- Mounts on any MetroMax i® or MetroMax Q shelf.

Width/Length/Height		Approx. Pkd. Wt.		i and Q
(in.)	(mm)	(lbs.)	(kg)	Cat. No.
7 <sup>1</sup> / <sub>8</sub> x25 <sup>5</sup> / <sub>16</sub> x15	200x643x381	10	4.5	<b>CR24E</b>

✓ Indicates antimicrobial product.

## Storage Level Frames — 9.25

- Open four sided frames accommodate drop-in accessories including wire baskets and stainless drying racks.
- Includes corrosion proof MetroMax i® frame and a bag of wedges.

Width (in.)	(mm)	Length		Inside Width/Length		Approx. Pkd. Wt.		<b>i and Q</b> Cat. No.
		(in.)	(mm)	(in.)	(mm)	(lbs.)	(kg)	
18	457	24	610	18x20	457x510	4 <sup>3</sup> / <sub>4</sub>	2.2	<b>M4F1824</b>
18	457	30	760	18x26	457x660	6	2.7	<b>M4F1830</b>
18	457	36	914	18x32	457x810	7	3.2	<b>M4F1836</b>
18	457	42	1060	18x38	457x965	8 <sup>1</sup> / <sub>4</sub>	3.8	<b>M4F1842</b>
18	457	48	1220	18x44	457x1120	9 <sup>1</sup> / <sub>2</sub>	4.3	<b>M4F1848</b>
18	457	54	1372	18x50	457x1219	10 <sup>1</sup> / <sub>2</sub>	4.8	<b>M4F1854</b>
18	457	60	1524	18x56	457x1370	11 <sup>3</sup> / <sub>4</sub>	5.3	<b>M4F1860</b>
18	457	72	1829	18x68	457x1725	14	6.4	<b>M4F1872</b>
24	610	24	610	24x20	610x510	7 <sup>1</sup> / <sub>2</sub>	3.4	<b>M4F2424</b>
24	610	30	760	24x26	610x660	9 <sup>1</sup> / <sub>2</sub>	4.3	<b>M4F2430</b>
24	610	36	914	24x32	610x810	11 <sup>1</sup> / <sub>4</sub>	5.1	<b>M4F2436</b>
24	610	42	1060	24x38	610x965	13 <sup>1</sup> / <sub>4</sub>	6	<b>M4F2442</b>
24	610	48	1220	24x44	610x1120	15	6.8	<b>M4F2448</b>
24	610	54	1372	24x50	610x1219	17	7.7	<b>M4F2454</b>
24	610	60	1524	24x56	610x1370	18 <sup>3</sup> / <sub>4</sub>	8.5	<b>M4F2460</b>
24	610	72	1829	24x68	610x1725	22 <sup>1</sup> / <sub>2</sub>	10.2	<b>M4F2472</b>



## Configuration Chart

FRAME	QTY to fill out shelf frame.			
	B1816XE	B1822XE	B2416XE	B2422XE
M4F1836	2			
M4F1842	1	1		
M4F1848		2		
M4F1860	2	1		
M4F1872		3		
M4F2436		2		
M4F2442		1	1	
M4F2448			2	
M4F2460		2	1	
M4F2472			3	

## Wire Baskets — 9.25

- Conveniently hold small items.
- 9" (229mm) deep.
- Built in storage handles allow easy removal.
- Corrosion resistant taupe epoxy finish.
- Weight Capacity: 50 lbs. (23 kg)
- Installs flat.

Width (in.)	(mm)	Length		Approx. Pkd. Wt.		Cat. No.
		(in.)	(mm)	(lbs.)	(kg)	
18	457	16	406	9	4.1	<b>MB1816XE</b>
18	457	22	560	10	4.5	<b>MB1822XE</b>
24	610	16	406	10	4.5	<b>MB2416XE</b>
24	610	22	560	12	5.5	<b>MB2422XE</b>



## 3-sided Frames — 9.25

- 1"x1<sup>1</sup>/<sub>2</sub>" (25x38mm) structural steel tubing. Includes tri-lobal adapters to attach to posts. (Replacement adapters: Cat. No. MTLA, bag of 4).
- Corrosion resistant taupe epoxy finish.
- Use when configuring work tables or as a 3-sided ledge to contain bulky items.

Width (in.)	(mm)	Length		Approx. Pkd. Wt.		<b>i and Q</b> Cat. No.
		(in.)	(mm)	(lbs.)	(kg)	
18	457	24	610	11	5	<b>M3TF1824E</b>
18	457	30	760	12	5.4	<b>M3TF1830E</b>
18	457	36	914	13	5.7	<b>M3TF1836E</b>
18	457	48	1220	15	6.6	<b>M3TF1848E</b>
18	457	60	1524	18	8.2	<b>M3TF1860E</b>
24	610	24	610	12	5.4	<b>M3TF2424E</b>
24	610	30	760	13	5.7	<b>M3TF2430E</b>
24	610	36	914	14	6.4	<b>M3TF2436E</b>
24	610	48	1220	18	8.2	<b>M3TF2448E</b>
24	610	60	1524	20	9.1	<b>M3TF2460E</b>



✓ Indicates antimicrobial product.

# Dry it.



PR48X3

### MetroMax i® Drying Rack Unit — 9.31

- Allows superior air circulation and fast drying of trays, pans, lids, pots and all pot sink items.
- Promotes food safety by eliminating moisture. Offers an efficient organized drying area.
- Mobile models come equipped with corrosion resistant polymer casters: (2) swivel 5PCX and (2) swivel/brake 5PCBX.
- Shelves, posts, and tray drying racks include Microban antimicrobial product protection
- NSF Listed

Models with two drop-ins (Cat. No. DR48S) and one cutting board/tray drying rack (Cat. No. MTR2448XE)

Configuration	Nominal Width		Nominal Length		Height		Pkd. Wt.		i Cat. No.
	(in.)	(mm)	(in.)	(mm)	(in.)	(mm)	(lbs.)	(kg)	
Stationary	24	610	48	1219	75½	1917	106	49	<b>PR48X3</b>
Mobile	24	610	48	1219	68	1727	106	49	<b>PR48VX3</b>

\*Note: Includes two 5PCX swivel casters and two 5PCBX swivel casters with brakes.



PR48VX4

Models with four cutting board/tray drying racks: (2) MTR2448XE and (2) MTR2448XEA

This rack is perfect for steam and bun pans, and one unit can hold up to 96 pans.

Configuration	Nominal Width		Nominal Length		Height		Pkd. Wt.		i Cat. No.
	(in.)	(mm)	(in.)	(mm)	(in.)	(mm)	(lbs.)	(kg)	
Stationary	24	610	48	1219	75½	1917	106	49	<b>PR48X4</b>
Mobile	24	610	48	1219	68	1727	106	49	<b>PR48VX4</b>

\*Note: Includes two 5PCX swivel casters and two 5PCBX swivel casters with brakes.

### Cutting Board and Tray Drying Rack — 9.25

- Rack is compatible with MetroMax i, MetroMax Q, Super Erecta Pro, Super Adjustable, and Super Erecta wire shelves.
- Promotes safe air drying of cutting boards and trays.
- 1 1/8" (28mm) and 3" (76mm) slide spacing available.

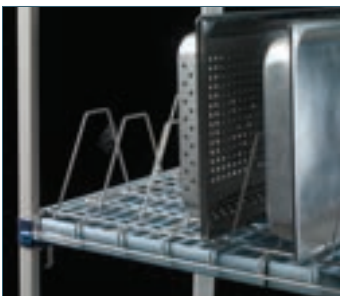

Fits Shelf	Upright Spacing	Upright Height	Tray Capacity	Pkd. Wt.		i and Q Cat. No.
				(in.)	(mm)	
24x36 610x914	1 1/8 28	6 150	24	13.5	6.1	<b>MTR2436XE</b>
24x48 610x1219	1 1/8 28	6 150	34	18.0	8.2	<b>MTR2448XE</b>
24x60 610x1524	1 1/8 28	6 150	42	22.5	10.2	<b>MTR2460XE</b>
24x36 610x914	3 76	6 150	10	9.8	4.4	<b>MTR2436XEA</b>
24x48 610x1219	3 76	6 150	14	13	5.9	<b>MTR2448XEA</b>
24x60 610x1524	3 76	6 150	17	16.3	7.4	<b>MTR2460XEA</b>

\*Note: Can be retrofitted to original MetroMax and MetroMax Q.

✓ Indicates antimicrobial product.

**Stainless Steel Drop-in Racks — 9.25**

- Open wire design provides air flow to safely dry pots, pans, and containers
- Are installed over an open MetroMax i frame and center beam.
- Can be retrofitted to existing MetroMax i® shelves. Simply remove the mats and drop in the stainless drying rack.

How to order: (1) drop-in rack, (1) 4-sided shelf frame, (1) replacement center beam

Width (in.) (mm)		Length (in.) (mm)		Height (in.) (mm)		Wire Spacing (in.) (mm)		Approx. Pkd. Wt. (lbs.) (kg)		Cat. No.
24	610	33 <sup>7</sup> / <sub>8</sub>	854	5 <sup>1</sup> / <sub>4</sub>	133	<sup>3</sup> / <sub>4</sub>	19	9	4.1	<b>DR36S</b>
24	610	45 <sup>7</sup> / <sub>8</sub>	1156	5 <sup>1</sup> / <sub>4</sub>	133	<sup>3</sup> / <sub>4</sub>	19	12	5.4	<b>DR48S</b>
24	610	57 <sup>7</sup> / <sub>8</sub>	1458	5 <sup>1</sup> / <sub>4</sub>	133	<sup>3</sup> / <sub>4</sub>	19	15	6.8	<b>DR60S</b>

\*Note: Can be retrofitted to original MetroMax and MetroMax Q.

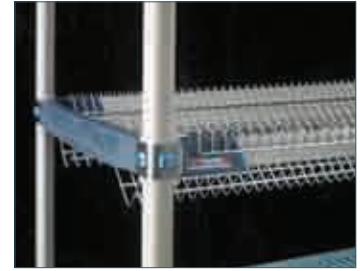

Shelf Frames — See page 27.

**Replacement Center Beam**

Fits Shelf Frame (in.) (mm)		Cat. No.
24 x 36	610 x 914	<b>RPMX36-CBEAM</b>
24 x 48	610 x 1219	<b>RPMX48-CBEAM</b>
24 x 60	610 x 1524	<b>RPMX60-CBEAM</b>

**MetroMax i® Sloped Basket Cart — 30.20**

- Ideal for compartmentalizing bulk, odd-shaped supplies.
- Baskets have a semi open front for easy access.
- Baskets can mount flat or at a 10° angle for stock rotation
- Dividers adjust horizontally

Description	Height/Width/Length (in.) (mm)		Total Baskets Per Cart	Casters	Cat. No.
Open Cart	60x24x24	1524x610x610	4	*	<b>MXIV1</b>
Open Cart with Top Shelf	69x24x24	1753x610x610	4	*	<b>MXIV2</b>
Open Cart	60x24x42	1524x610x1066	8	†	<b>MXIV4</b>
Open Cart with Top Shelf	69x24x42	1753x610x1066	8	†	<b>MXIV5</b>
Open Cart	60x24x60	1524x610x1524	12	†	<b>MXIV6</b>
Open Cart with Top Shelf	69x24x60	1753x610x1524	12	†	<b>MXIV7</b>

Note: Each basket sold with cart includes two dividers and a label holder.  
 \*Four 5" (127mm) poly casters; two swivel, two with brakes.  
 †5" (127mm) poly casters on dolly frame; two swivel, one swivel with brake, and one rigid.



**Accessories**

Description	(in.)	(mm)	Cat. No.
Basket with Label Holder	18 <sup>1</sup> / <sub>2</sub> x24 <sup>1</sup> / <sub>2</sub> x10	470x622x254	<b>IVB1</b>
Divider	9	229	<b>IVBD</b>

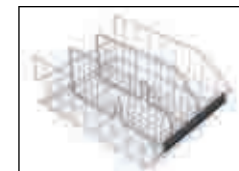

IVB1  
(shown with optional Divider)



# WIRE AND SOLID SHELVING SOLUTIONS

Super Erecta Pro,<sup>™</sup>  
Super Adjustable Super Erecta<sup>®</sup>  
and Super Erecta<sup>®</sup>

Wire/Polymer Hybrid Shelving .....	32-35
Easy-Adjust Shelving & Carts .....	36-39
Wire Shelving, Carts & Trucks.....	40-49
Casters & Accessories for Wire Shelving .....	50-64
Solid Shelving & Accessories .....	65-68
Light-Duty Wire Shelving & Accessories .....	69
Heavy-Duty Solid Shelving & Accessories .....	70-71

# Proven.

Genuine Metro Super Erecta®  
The industry standard — innovated and reinnovated.

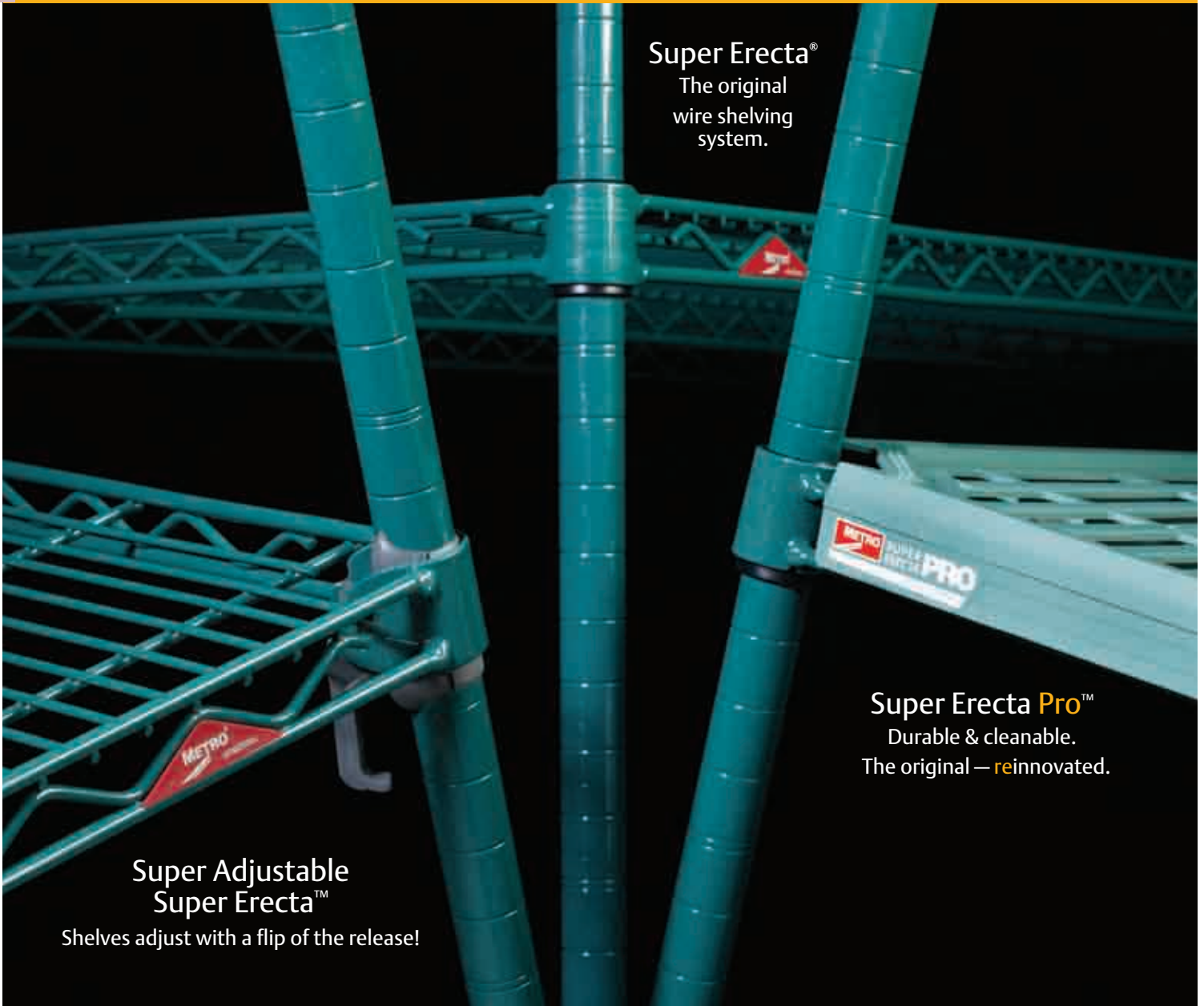

Super Erecta®  
The original  
wire shelving  
system.

Super Erecta Pro™  
Durable & cleanable.  
The original — reinnovated.

Super Adjustable  
Super Erecta™

Shelves adjust with a flip of the release!



# Progress.

Super Erecta Pro™  
Durable & cleanable.  
The original — **re**innovated.



Epoxy coated Super Erecta-style frames with removable polymer shelf mats.

**Stays cleaner between cleanings.**

Polymer shelf mats and Metroseal 3 epoxy coated shelf frames and posts have built-in Microban® antimicrobial product protection.



\*Microban® antimicrobial product protection helps keep shelves "cleaner between cleanings" by inhibiting the growth of bacteria, mold and mildew that cause odors and stains on the shelf surface. MICROBAN® and the MICROBAN® symbol are registered trademarks of the Microban Products Company, Huntersville, NC.

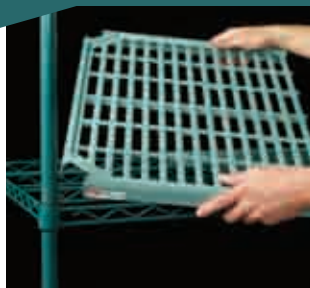

**Easy to clean.**

Lift-off mats can be easily removed and washed by hand or in a wash machine.

**Prolonged durability.**

Polymer shelf mats withstand daily abuse from containers and sharp edges. Robust design provides the strength and rigidity of Super Erecta...holds up to 800 lbs. (363kg) per shelf.



**Interchangeable.**

Super Erecta Pro shelves can be configured with traditional shelf and accessory options on the same unit for maximum flexibility.

Super Erecta Pro™ Shelving — 10.80



Super Erecta Pro™ Shelves

Packaging: Shelves are priced individually and packaged no more than 4 per carton except 60" (1524mm) and 72" (1829mm) lengths which are packaged no more than 2 per carton. Plastic split sleeves are included with each shelf.

Nominal Width/Length (in./mm)		Approx. Pkd. Wt. (lbs./kg)		Cat. No. Super Erecta Pro Metroseal 3
18x24	457x610	6.0	2.7	PR1824NK3
18x30	457x760	7.8	3.5	PR1830NK3
18x36	457x914	9.5	4.2	PR1836NK3
18x42	457x1060	11.3	5.0	PR1842NK3
18x48	457x1219	13.0	5.8	PR1848NK3
18x54	457x1372	14.8	6.6	PR1854NK3
18x60	457x1524	16.5	7.4	PR1860NK3
18x72	457x1829	19.8	8.8	PR1872NK3
21x24	530x610	8.0	3.6	PR2124NK3
21x30	530x760	9.5	4.2	PR2130NK3
21x36	530x914	11.3	5.0	PR2136NK3
21x42	530x1060	12.5	5.6	PR2142NK3
21x48	530x1219	14.3	6.4	PR2148NK3
21x54	530x1372	16.5	7.4	PR2154NK3
21x60	530x1524	18.3	8.1	PR2160NK3
21x72	530x1829	21.5	9.6	PR2172NK3
24x24	610x610	9.5	4.2	PR2424NK3
24x30	610x760	11.3	5.0	PR2430NK3
24x36	610x914	13.0	5.8	PR2436NK3
24x42	610x1060	14.0	6.3	PR2442NK3
24x48	610x1219	15.5	6.9	PR2448NK3
24x54	610x1372	18.3	8.1	PR2454NK3
24x60	610x1524	20.0	8.9	PR2460NK3
24x72	610x1829	23.3	10.4	PR2472NK3

Note: Each Super Erecta Pro™ shelf up to and including 48" (1219mm) long have a maximum weight capacity of 800 lbs. (363kg) evenly distributed. Shelves longer than 48" (1219mm) have a maximum weight capacity of 600 lbs. (272kg) evenly distributed.

Super Erecta with Metroseal 3™ — Standard Shelves

Nominal Width/Length (in./mm)		Approx. Pkd. Wt. (lbs./kg)		Cat. No. Super Adjustable Metroseal 3	Cat. No. Super Erecta Metroseal 3	Approx. Pkd. Wt. (lbs./kg)		Cat. No. Dunnage Shelf Metroseal 3
18x24	457x610	7	3.2	A1824NK3	1824NK3	14	6.3	1824DRK3
18x30	457x760	8	3.6	A1830NK3	1830NK3	18	8.1	1830DRK3
18x36	457x914	9.5	4.3	A1836NK3	1836NK3	21	9.4	1836DRK3
18x42	457x1060	11	5.0	A1842NK3	1842NK3	—	—	—
18x48	457x1219	12	5.4	A1848NK3	1848NK3	28	12.6	1848DRK3
18x54	457x1372	14.5	6.6	A1854NK3	1854NK3	—	—	—
18x60	457x1524	17	7.7	A1860NK3	1860NK3	34	15.3	1860DRK3
18x72	457x1829	20	9.1	A1872NK3	1872NK3	—	—	—
21x24	530x610	8	3.6	A2124NK3	2124NK3	—	—	—
21x30	530x760	9	4.1	A2130NK3	2130NK3	—	—	—
21x36	530x914	11	5.0	A2136NK3	2136NK3	—	—	—
21x42	530x1060	12	5.4	A2142NK3	2142NK3	—	—	—
21x48	530x1219	14	6.4	A2148NK3	2148NK3	—	—	—
21x54	530x1372	16	7.3	A2154NK3	2154NK3	—	—	—
21x60	530x1524	18	8.2	A2160NK3	2160NK3	—	—	—
21x72	530x1829	24	10.9	A2172NK3	2172NK3	—	—	—
24x24	610x610	9	4.1	A2424NK3	2424NK3	16	7.2	2424DRK3
24x30	610x760	11	5.0	A2430NK3	2430NK3	20	9.0	2430DRK3
24x36	610x914	13	5.9	A2436NK3	2436NK3	24	10.8	2436DRK3
24x42	610x1060	15	6.8	A2442NK3	2442NK3	—	—	—
24x48	610x1219	16	7.3	A2448NK3	2448NK3	30	13.5	2448DRK3
24x54	610x1372	19	8.6	A2454NK3	2454NK3	—	—	—
24x60	610x1524	21	9.5	A2460NK3	2460NK3	37	16.6	2460DRK3
24x72	610x1829	26	11.8	A2472NK3	2472NK3	—	—	—

Actual Dimensions: Width: Add 1/4" (6mm) to nominal size. Length: Subtract 1/4" (6mm) from nominal size.

✓ Indicates antimicrobial product.

Super Erecta Pro shelves are also compatible on the same shelving units with the following Super Erecta items:

- Solid Shelves page 67
- Cantilever Shelves page 46
- SmartWall G3 page 74
- Post Type Wall Mounts page 81
- Direct Mount Shelf Supports page 82
- Three sided frames page 57
- Enclosure Panels page 56
- Security Units page 103
- Top Track page 96
- qwikTRAK page 94



Super Erecta Pro™ Shelving — 10.80

SiteSelect™ Posts

Stationary Super Erecta SiteSelect posts are fitted with adjustable leveling bolts to compensate for uneven surfaces. Mobile posts come without leveling bolt assembly to accommodate stem casters. Special length posts are available. See page 50 for stem caster options.

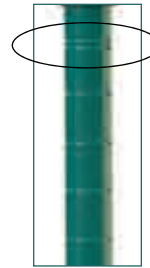

SiteSelect posts provide a visual guide for positioning and adjusting shelves, saving considerable time during assembly and adjustment. An easy-to-identify double groove, every 8" (203mm), offers a quick way to align all shelves.

Stationary

Mobile

Height (in.)	Height (mm)	Approx. Pkd. Wt. (lbs.)	Approx. Pkd. Wt. (kg)	Cat. No. Metroseal 3	Cat. No. Stainless
14 <sup>1</sup> / <sub>2</sub>	370	1	0.5	13PK3	13PS
34 <sup>1</sup> / <sub>2</sub>	875	2	0.9	33PK3	33PS
54 <sup>9</sup> / <sub>16</sub>	1385	3	1.4	54PK3	54PS
62 <sup>9</sup> / <sub>16</sub>	1590	3 <sup>1</sup> / <sub>2</sub>	1.6	63PK3	63PS
74 <sup>5</sup> / <sub>8</sub>	1895	4	1.8	74PK3	74PS
86 <sup>5</sup> / <sub>8</sub>	2200	5	2.3	86PK3	86PS

Height (in.)	Height (mm)	Approx. Pkd. Wt. (lbs.)	Approx. Pkd. Wt. (kg)	Cat. No. Metroseal 3	Cat. No. Stainless
13 <sup>3</sup> / <sub>4</sub>	349	1	0.5	13UPK3	13UPS
33 <sup>3</sup> / <sub>4</sub>	857	2	0.9	33UPK3	33UPS
53 <sup>13</sup> / <sub>16</sub>	1366	3	1.4	54UPK3	54UPS
61 <sup>13</sup> / <sub>16</sub>	1570	3 <sup>1</sup> / <sub>2</sub>	1.6	63UPK3	63UPS
69 <sup>3</sup> / <sub>4</sub>	1772	3.8	1.7	70UPK3	—
73 <sup>7</sup> / <sub>8</sub>	1876	4	1.8	74UPK3	74UPS
85 <sup>7</sup> / <sub>8</sub>	2181	5	2.3	86UPK3	86UPS

Accessories — 10.81

Note: These accessories are designed to attach to a Super Erecta Pro Shelf. Accessories for basic Super Erecta wire shelves can be found on pages 53-60. For a complete list of compatible accessories for Super Erecta Pro shelves, please refer to spec sheet 10.81 for more information.

“S” Hooks

Eliminates the need for adjacent posts. Two required for each storage level. Cat. No. Q9995Z

Universal Divider

- Corrosion proof

Nominal Length (in.)	Length (mm)	Fits Shelf Depth	Approx. Pkd. Wt. (lbs.)	Approx. Pkd. Wt. (kg)	Cat. No.
18	457	18", 21" (457, 530mm)	1.3	0.6	MUD18-8
24	610	24" (610mm)	1.6	0.7	MUD24-8

Shelf-to-Shelf Divider

- Connects between two shelves
- Corrosion proof

Nominal Height (in.)	Height (mm)	Compatible with Shelf Depths (in.)	Compatible with Shelf Depths (mm)	Approx. Pkd. Wt. (lbs.)	Approx. Pkd. Wt. (kg)	Cat. No.
16	406	18, 21	457, 530	2.3	1.0	MD18-16
20	508	18, 21	457, 530	2.5	1.1	MD18-20
24	610	18, 21	457, 530	3.8	1.7	MD18-24
16	406	24	610	2.8	1.2	MD24-16
20	508	24	610	3.0	1.3	MD24-20
24	610	24	610	4.4	2.0	MD24-24

Color Shelf Marker

- 6" (152mm) Length
- Fits Super Erecta Pro Shelf
- Attach easily to shelf to identify contents stored.

Color	Length (in.)	Length (mm)	Approx. Pkd. Wt. (lbs.)	Approx. Pkd. Wt. (kg)	Cat. No.
Blue	6	152	0.05	0.02	CSM6-BQ
Green	6	152	0.05	0.02	CSM6-GQ
Red	6	152	0.05	0.02	CSM6-RQ
Tan	6	152	0.05	0.02	CSM6-TQ
White	6	152	0.05	0.02	CSM6-WQ
Yellow	6	152	0.05	0.02	CSM6-YQ
Gray	6	152	0.05	0.02	CSM6-GRQ

Label Holders

- Fits Super Erecta Pro Shelf
- Plastic holders snap into place to accommodate 1" (25mm) tall adhesive label.

Cat. No. Q04LH

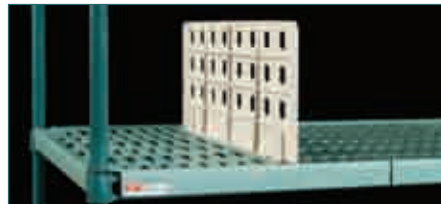

Indicates antimicrobial product.

# Reclaim Wasted Space.



**Super Adjustable™  
Super Erecta® Shelving**

**Adjust and add shelves  
quickly and easily  
to reclaim wasted space.**



Super Erecta

Easy “no-tool”  
shelf adjustment

1" (25mm)  
spacing minimizes  
dead space

Efficient use of space  
allows more storage  
levels to be added.

**Storage efficiency  
can increase  
by 25% or more**



Super Adjustable  
Super Erecta





# SUPER ADJUSTABLE SUPER ERECTA® SHELVING

## Super Adjustable Wire Shelves — 10.01a 10.10a

Packaging: Wire shelves are priced individually and packaged no more than 4 per carton except 60" (1524mm) and 72" (1829mm) lengths and 30" (760mm) and 36" (914mm) widths, which are packaged no more than 2 per carton. Plastic sleeves and wedges are included with each shelf.

Width/Length (in.) (mm)		Approx. Pkd. Wt. (lbs.) (kg)		Cat. No. Chrome	Cat. No. Metroseal 3 with Microban®	Cat. No. Stainless
14x24	355x610	6	2.7	A1424NC	A1424NK3	A1424NS
14x30	355x760	7	3.2	A1430NC	A1430NK3	A1430NS
14x36	355x914	8	3.6	A1436NC	A1436NK3	A1436NS
14x42	355x1066	9½	4.3	A1442NC	A1442NK3	A1442NS
14x48	355x1219	10½	4.7	A1448NC	A1448NK3	A1448NS
14x60	355x1524	14	6.3	A1460NC	A1460NK3	A1460NS
14x72	355x1825	17	7.7	A1472NC	A1472NK3	A1472NS
18x24	457x610	7	3.2	A1824NC	A1824NK3	A1824NS
18x30	457x760	8	3.6	A1830NC	A1830NK3	A1830NS
18x36	457x914	9½	4.3	A1836NC	A1836NK3	A1836NS
18x42	457x1066	11	5.0	A1842NC	A1842NK3	A1842NS
18x48	457x1219	12	5.4	A1848NC	A1848NK3	A1848NS
18x54	457x1370	14½	6.6	A1854NC	A1854NK3	A1854NS
18x60	457x1524	17	7.7	A1860NC	A1860NK3	A1860NS
18x72	457x1829	20	9.1	A1872NC	A1872NK3	A1872NS
21x24	530x610	8	3.6	A2124NC	A2124NK3	A2124NS
21x30	530x760	9	4.1	A2130NC	A2130NK3	A2130NS
21x36	530x914	11	5.0	A2136NC	A2136NK3	A2136NS
21x42	530x1066	12	5.4	A2142NC	A2142NK3	A2142NS
21x48	530x1219	14	6.4	A2148NC	A2148NK3	A2148NS
21x54	530x1370	16	7.3	A2154NC	A2154NK3	A2154NS
21x60	530x1524	18	8.2	A2160NC	A2160NK3	A2160NS
21x72	530x1829	24	10.9	A2172NC	A2172NK3	A2172NS
24x24	610x610	9	4.1	A2424NC	A2424NK3	A2424NS
24x30	610x760	11	5.0	A2430NC	A2430NK3	A2430NS
24x36	610x914	13	5.9	A2436NC	A2436NK3	A2436NS
24x42	610x1066	15	6.8	A2442NC	A2442NK3	A2442NS
24x48	610x1219	16	7.3	A2448NC	A2448NK3	A2448NS
24x54	610x1370	18	8.6	A2454NC	A2454NK3	A2454NS
24x60	610x1524	21	9.5	A2460NC	A2460NK3	A2460NS
24x72	610x1829	26	11.8	A2472NC	A2472NK3	A2472NS
30x36	760x914	15	6.8	A3036NC		A3036NS
30x48	760x1219	21	9.5	A3048NC		A3048NS
30x60	760x1524	26½	11.8	A3060NC		A3060NS
30x72	760x1829	31	14.0	A3072NC		A3072NS
36x36	910x914	18	8.2	A3636NC		A3636NS
36x48	910x1219	23	10.4	A3648NC		A3648NS
36x60	910x1524	29	13.1	A3660NC		A3660NS
36x72	910x1829	34½	15.4	A3672NC		A3672NS

Note: For availability of Super Adjustable Shelving not listed above, contact your Metro representative.

## SiteSelect™ Posts — 10.01a 10.10a

Stationary Super Erecta® SiteSelect posts are fitted with adjustable leveling bolts to compensate for uneven surfaces. Mobile posts come without leveling bolt assembly to accommodate stem casters. Special length posts are available.†

STATIONARY				
Height* (in.) (mm)	Approx. Pkd. Wt. (lbs.) (kg)	Cat. No. Chrome	Cat. No. Metroseal 3 with Microban®	Cat. No. Stainless**
7½	191	7P	7PK3	
14½	370	13P	13PK3	13PS
27½	699	27P	27PK3	27PS
34½	875	33P	33PK3	33PS
54 <sup>9</sup> / <sub>16</sub>	1385	54P	54PK3	54PS
62 <sup>9</sup> / <sub>16</sub>	1590	63P	63PK3	63PS
74 <sup>5</sup> / <sub>8</sub>	1895	74P	74PK3	74PS
86 <sup>5</sup> / <sub>8</sub>	2200	86P	86PK3	86PS
96 <sup>5</sup> / <sub>8</sub>	2454	5½	2.5	***96P

MOBILE				
Approx. Pkd. Wt. (lbs.) (kg)	Cat. No. Plated	Cat. No. Metroseal 3 with Microban®	Cat. No. Stainless	
1	0.5	13UP	13UPK3	13UPS
1¾	0.75	27UP	27UPK3	27UPS
2	0.9	33UP	33UPK3	33UPS
3	1.4	54UP	54UPK3	54UPS
3½	1.6	63UP	63UPK3	63UPS
3¾	1.7		70UPK3	
4	1.8	74UP	74UPK3	74UPS
4.5	2.0	86UP	86UPK3	86UPS

These posts come without leveling bolt assembly to accommodate stem casters.

\*Height includes leveling bolt and cap.

\*\*Stainless stationary post includes stainless leveling bolt.

\*\*\*96P should not be used on units less than 24" (610mm) deep. Consult Metro Engineering for alternate recommendations.

†Note: Special length posts are available, priced at next higher length plus a cutting charge.

Post lengths to be specified as cut to a round number, ie: 74P cut to 69" (1753mm) . . . This will result in an overall post height with adjustment of 69<sup>9</sup>/<sub>8</sub>" (1762mm) to 69<sup>7</sup>/<sub>8</sub>" (1775mm).

\*MICROBAN® and the MICROBAN® symbol are registered trademarks of the Microban Products Company, Huntersville, NC.

Indicates antimicrobial product.



**Shelving Starter and Add-On Units**

Save time and money by eliminating adjacent posts and replacing with "S" hooks.

- Starter Units consist of four posts and indicated number of Super Adjustable Super Erecta shelves.
- Add-On Units consist of two posts, indicated number of shelves, and two "S" Hooks per shelf, for attaching shelf to adjacent unit.



**Replacement "S" Hook**  
2 are required for each storage level.  
Cat. No. **9995Z**

For additional wire shelves, order from page 37.

Add-on units with "S" hooks can only be attached to shelves supported by two or more posts.



**Security "S" Hook**  
2 are required for each storage level.  
Chrome. Cat. No. **H9995C**  
Bag of 2  
Black. Cat. No. **H9995B**  
Bag of 2

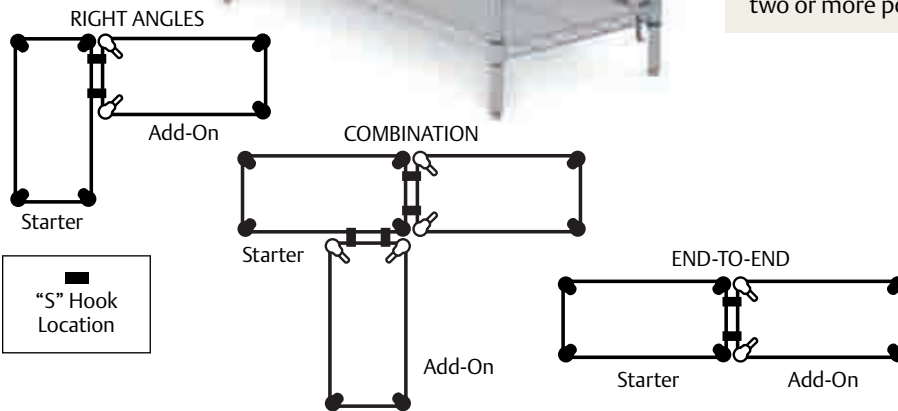

Indicates antimicrobial product.

**Shelving Starter and Add-On Units — Easy Order Guide**

		Chrome-Plated						Metroseal 3 with Microban®					
<b>5 Shelves</b>		18" (457mm) Wide		21" (530mm) Wide		24" (610mm) Wide		18" (457mm) Wide		21" (530mm) Wide		24" (610mm) Wide	
74" (1880mm) Posts (74P)		Starter	Add-On	Starter	Add-On	Starter	Add-On	Starter	Add-On	Starter	Add-On	Starter	Add-On
<b>24" (610mm)</b>	<b>Cat. No.</b>	<b>5A317C</b>	<b>5AA317C</b>	<b>5A417C</b>	<b>5AA417C</b>	<b>5A517C</b>	<b>5AA517C</b>	<b>5A317K3</b>	<b>5AA317K3</b>	<b>5A417K3</b>	<b>5AA417K3</b>	<b>5A517K3</b>	<b>5AA517K3</b>
<b>Long</b>	<b>Wt. lbs. (kg)</b>	51 (23)	43 (20)	57 (26)	48 (22)	62 (28)	53 (24)	51 (23)	43 (20)	57 (26)	48 (22)	62 (28)	53 (24)
<b>30" (760mm)</b>	<b>Cat. No.</b>	<b>5A327C</b>	<b>5AA327C</b>	<b>5A427C</b>	<b>5AA427C</b>	<b>5A527C</b>	<b>5AA527C</b>	<b>5A327K3</b>	<b>5AA327K3</b>	<b>5A427K3</b>	<b>5AA427K3</b>	<b>5A527K3</b>	<b>5AA527K3</b>
<b>Long</b>	<b>Wt. lbs. (kg)</b>	58 (26)	50 (23)	64 (29)	56 (25)	71 (32)	62 (28)	58 (26)	50 (23)	64 (29)	56 (25)	71 (32)	62 (28)
<b>36" (914mm)</b>	<b>Cat. No.</b>	<b>5A337C</b>	<b>5AA337C</b>	<b>5A437C</b>	<b>5AA437C</b>	<b>5A537C</b>	<b>5AA537C</b>	<b>5A337K3</b>	<b>5AA337K3</b>	<b>5A437K3</b>	<b>5AA437K3</b>	<b>5A537K3</b>	<b>5AA537K3</b>
<b>Long</b>	<b>Wt. lbs. (kg)</b>	65 (29)	57 (26)	73 (33)	65 (29)	81 (37)	73 (33)	65 (29)	57 (26)	73 (33)	65 (29)	81 (37)	73 (33)
<b>42" (1066mm)</b>	<b>Cat. No.</b>	<b>5A347C</b>	<b>5AA347C</b>	<b>5A447C</b>	<b>5AA447C</b>	<b>5A547C</b>	<b>5AA547C</b>	<b>5A347K3</b>	<b>5AA347K3</b>	<b>5A447K3</b>	<b>5AA447K3</b>	<b>5A547K3</b>	<b>5AA547K3</b>
<b>Long</b>	<b>Wt. lbs. (kg)</b>	70 (32)	62 (28)	81 (37)	73 (33)	89 (40)	81 (37)	70 (32)	62 (28)	81 (37)	73 (33)	89 (40)	81 (37)
<b>48" (1219mm)</b>	<b>Cat. No.</b>	<b>5A357C</b>	<b>5AA357C</b>	<b>5A457C</b>	<b>5AA457C</b>	<b>5A557C</b>	<b>5AA557C</b>	<b>5A357K3</b>	<b>5AA357K3</b>	<b>5A457K3</b>	<b>5AA457K3</b>	<b>5A557K3</b>	<b>5AA557K3</b>
<b>Long</b>	<b>Wt. lbs. (kg)</b>	78 (35)	70 (32)	88 (40)	80 (36)	98 (44)	90 (41)	78 (35)	70 (32)	88 (40)	80 (36)	98 (44)	90 (41)
<b>60" (1524mm)</b>	<b>Cat. No.</b>	<b>5A367C</b>	<b>5AA367C</b>	<b>5A467C</b>	<b>5AA467C</b>	<b>5A567C</b>	<b>5AA567C</b>	<b>5A367K3</b>	<b>5AA367K3</b>	<b>5A467K3</b>	<b>5AA467K3</b>	<b>5A567K3</b>	<b>5AA567K3</b>
<b>Long</b>	<b>Wt. lbs. (kg)</b>	102 (46)	93 (42)	109 (49)	101 (46)	122 (55)	113 (51)	102 (46)	93 (42)	109 (49)	101 (46)	122 (55)	113 (51)
<b>72" (1829mm)</b>	<b>Cat. No.</b>	<b>5A377C</b>	<b>5AA377C</b>	<b>5A477C</b>	<b>5AA477C</b>	<b>5A577C</b>	<b>5AA577C</b>	<b>5A377K3</b>	<b>5AA377K3</b>	<b>5A477K3</b>	<b>5AA477K3</b>	<b>5A577K3</b>	<b>5AA577K3</b>
<b>Long</b>	<b>Wt. lbs. (kg)</b>	117 (53)	108 (49)	122 (55)	113 (51)	149 (68)	141 (64)	117 (53)	108 (49)	122 (55)	113 (51)	149 (68)	141 (64)

Super Adjustable Super Erecta® Stem Caster Carts — 11.01a

- Four- and five-tier models available.
- Consists of Super Adjustable Super Erecta wire shelves.
- 5" (127mm) resilient rubber or polyurethane casters with donut bumpers.
- Super Adjustable Super Erecta shelves allow for quick and easy adjustability.
- Open-wire shelf design minimizes dust and increases air circulation and visibility.
- Strong and versatile. (See Metro Fact below)
- For additional storage levels, Super Adjustable shelves may be added as desired. (See page 37.)



Super Adjustable Super Erecta® Wire Stem Caster Cart

**Metro Fact:**

Carts with polyurethane casters are designed to hold up to 900 lbs. (408kg). Carts with rubber casters can hold up to 600 lbs. (272kg) of evenly distributed weight. Heavier weight loads should be stored as low as possible on cart for safe maneuverability.



Lift the release at each corner to adjust Super Adjustable shelves at 1" (25mm) increments in seconds.

Use a solid shelf on the lowest levels to protect contents on the bottom of the cart from debris and dripping. (See page 67).

**4-Tier Models**

With Chrome Shelves and Chrome-Plated Posts  
Overall Height 67<sup>7</sup>/<sub>8</sub>" (1724mm)

Shelf Width/Length (in.)	Shelf Width/Length (mm)	Approx. Pkd. Wt. (lbs.) (kg)	Catalog Number with Casters	
			Two Swivel Two Brake Resilient Rubber Casters	Two Swivel Two Brake Polyurethane Casters
18x36	457x914	60 27	<b>A336BC</b>	<b>A336EC</b>
18x48	457x1219	72 32	<b>A356BC</b>	<b>A356EC</b>
18x60	457x1524	88 40	<b>A366BC</b>	<b>A366EC</b>
21x36	530x914	69 31	<b>A436BC</b>	<b>A436EC</b>
21x48	530x1219	81 36	<b>A456BC</b>	<b>A456EC</b>
21x60	530x1524	98 44	<b>A466BC</b>	<b>A466EC</b>
24x36	610x914	76 34	<b>A536BC</b>	<b>A536EC</b>
24x48	610x1219	92 41	<b>A556BC</b>	<b>A556EC</b>
24x60	610x1524	112 51	<b>A566BC</b>	<b>A566EC</b>

Note: Models include 63UP posts.

**5-Tier Models**

With Chrome Shelves and Chrome-Plated Posts  
Overall Height 67<sup>7</sup>/<sub>8</sub>" (1724mm)

Shelf Width/Length (in.)	Shelf Width/Length (mm)	Approx. Pkd. Wt. (lbs.) (kg)	Catalog Number with Casters	
			Two Swivel Two Brake Resilient Rubber Casters	Two Swivel Two Brake Polyurethane Casters
18x36	457x914	60 27	<b>5A336BC</b>	<b>5A336EC</b>
18x48	457x1219	72 32	<b>5A356BC</b>	<b>5A356EC</b>
18x60	457x1524	88 40	<b>5A366BC</b>	<b>5A366EC</b>
21x36	530x914	69 31	<b>5A436BC</b>	<b>5A436EC</b>
21x48	530x1219	81 36	<b>5A456BC</b>	<b>5A456EC</b>
21x60	530x1524	98 44	<b>5A466BC</b>	<b>5A466EC</b>
24x36	610x914	76 34	<b>5A536BC</b>	<b>5A536EC</b>
24x48	610x1219	92 41	<b>5A556BC</b>	<b>5A556EC</b>
24x60	610x1524	112 51	<b>5A566BC</b>	<b>5A566EC</b>

Note: Models include 63UP posts.

# Genuine Quality.

Genuine Metro!

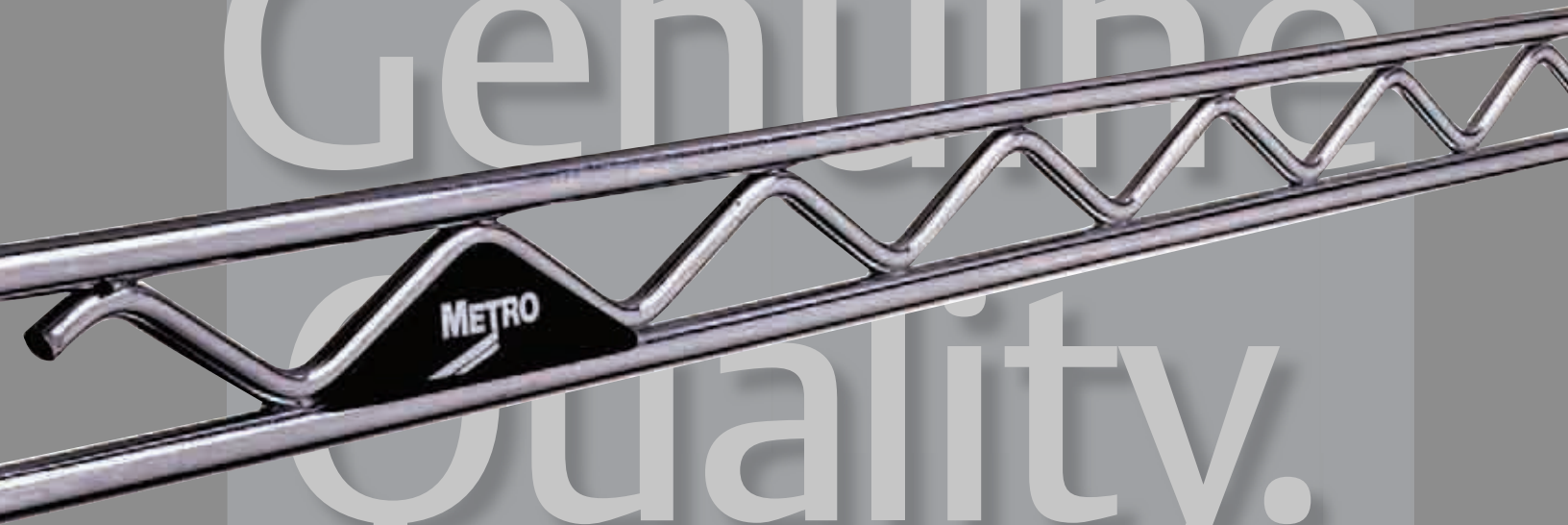

## Super Erecta® Shelving System The original wire storage system.

A storage system that defines the extent of space, Super Erecta's revolutionary concept was fresh and innovative from its start — nearly 50 years ago. It has continued to evolve, with nearly 100 highly specialized accessories, aimed at meeting the diversity of today's challenges.

- Adjustable: Shelves can be repositioned at precise 1" (25mm) increments along the length of the numbered posts.
- Unique Design: Open-wire design minimizes dust accumulation, allows a free circulation of air, and greater visibility of stored items.
- Mobile: Full choice of caster types available for mobile applications.

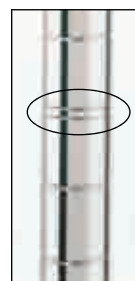

SiteSelect posts provide a visual guide for positioning and adjusting shelves, saving considerable time during assembly and adjustment. An easy-to-identify double groove, every 8" (203mm), offers a quick way to align all shelves.

### Metro Fact:

#### Genuine Metro!

Metro created the original post-based shelving unit in 1965. Still today, Metro Super Erecta Shelving is recognized worldwide as the most popular commercial shelving system ever.

# Strong to the Finish.

## Shelving Finishes Guide

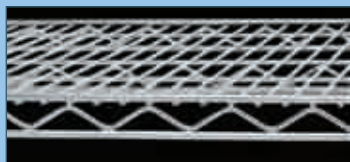

Wire & Solid



### Type 304 Polished Stainless Steel

Addresses the most aggressive applications and environments. All-stainless solid and wire options exist for high temperature automated cart wash and autoclave applications.



### Metroseal 3™ Epoxy

Corrosion resistant finish for wet or high humidity environments with a 12 year warranty against rust and corrosion. Microban antimicrobial is built into the finish to keep the product “cleaner between cleanings”.

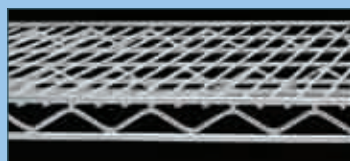

### Chrome Plating

The “real” nickel-chrome finish for dry, low humidity environments. Metro’s durable chrome finish includes a protective lacquer coat.

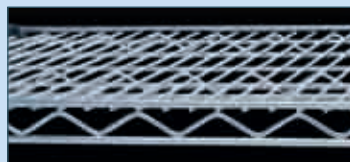

### Brite

Economical, chromate finish for dry, low humidity environments. Metro’s Brite finish provides the look of chrome and includes a protective lacquer coat.



## Standard Epoxy and Designer Finishes

A pleasing aesthetic and basic protection for dry environments.



## Shelving Post Guide

**Standard Stationary Post** with adjustable leveling foot. Stainless models also feature a stainless leveling foot. Use Foot Plates for greater stability.

**Standard Stem Caster Mobile Post** accepts a Metro stem caster. Use these for the majority of standard duty transport and movable storage applications.

### Cart Wash and Autoclave Applications

Swaged stainless post has a fastened aluminum post cap and is specifically designed to withstand high temperatures. See page 50 for part numbers.

### Heavy Duty Transport

Staked post attaches to a dolly truck to address abusive transport applications. The reinforced connection between the base receptacle and post provides a more secure connection to the dolly truck. See page 52 for part numbers.





Wire Shelves — 10.01a 10.10a

Packaging: Wire shelves are priced individually and packaged no more than 4 per carton except 60" (1524mm) and 72" (1829mm) lengths and 30" (760mm) and 36" (914mm) widths, which are packaged no more than 2 per carton. Plastic sleeves and wedges are included with each shelf.

Width/Length (in.) (mm)		Approx. Pkd. Wt. (lbs.) (kg)		Cat. No. Super Erecta Brite	Cat. No. Chrome	Cat. No. Metroseal 3 with Microban®	Cat. No. Stainless
14x24	355x610	6	2.7	1424BR	1424NC	1424NK3	1424NS
14x30	355x760	7	3.2	1430BR	1430NC	1430NK3	1430NS
14x36	355x914	8	3.6	1436BR	1436NC	1436NK3	1436NS
14x42	355x1066	9 1/2	4.3	1442BR	1442NC	1442NK3	1442NS
14x48	355x1219	10 1/2	4.7	1448BR	1448NC	1448NK3	1448NS
14x60	355x1524	14	6.3	1460BR	1460NC	1460NK3	1460NS
14x72	355x1829	17	7.7	1472BR	1472NC	1472NK3	1472NS
18x18	457x457	6	2.7	N/A	1818NC	N/A	N/A
18x24	457x610	7	3.2	1824BR	1824NC	1824NK3	1824NS
18x30	457x760	8	3.6	1830BR	1830NC	1830NK3	1830NS
18x36	457x914	9 1/2	4.3	1836BR	1836NC	1836NK3	1836NS
18x42	457x1066	11	5.0	1842BR	1842NC	1842NK3	1842NS
18x48	457x1219	12	5.4	1848BR	1848NC	1848NK3	1848NS
18x54	457x1370	14 1/2	6.6	1854BR	1854NC	1854NK3	1854NS
18x60	457x1524	17	7.7	1860BR	1860NC	1860NK3	1860NS
18x72	457x1829	20	9.1	1872BR	1872NC	1872NK3	1872NS
21x24	530x610	8	3.6	2124BR	2124NC	2124NK3	2124NS
21x30	530x760	9	4.1	2130BR	2130NC	2130NK3	2130NS
21x36	530x914	11	5.0	2136BR	2136NC	2136NK3	2136NS
21x42	530x1066	12	5.4	2142BR	2142NC	2142NK3	2142NS
21x48	530x1219	14	6.4	2148BR	2148NC	2148NK3	2148NS
21x54	530x1370	16	7.3	2154BR	2154NC	2154NK3	2154NS
21x60	530x1524	18	8.2	2160BR	2160NC	2160NK3	2160NS
21x72	530x1829	24	10.9	2172BR	2172NC	2172NK3	2172NS
24x24	610x610	9	4.1	2424BR	2424NC	2424NK3	2424NS
24x30	610x760	11	5.0	2430BR	2430NC	2430NK3	2430NS
24x36	610x914	13	5.9	2436BR	2436NC	2436NK3	2436NS
24x42	610x1066	15	6.8	2442BR	2442NC	2442NK3	2442NS
24x48	610x1219	16	7.3	2448BR	2448NC	2448NK3	2448NS
24x54	610x1370	19	8.6	2454BR	2454NC	2454NK3	2454NS
24x60	610x1524	21	9.5	2460BR	2460NC	2460NK3	2460NS
24x72	610x1829	26	11.8	2472BR	2472NC	2472NK3	2472NS
30x36	760x914	15	6.8	3036BR	3036NC	3036NK3	3036NS
30x48	760x1219	21	9.5	3048BR	3048NC	3048NK3	3048NS
30x60	760x1524	26 1/2	11.8	3060BR	3060NC	3060NK3	3060NS
30x72	760x1829	31	14.0	3072BR	3072NC	3072NK3	3072NS
36x36	910x914	18	8.2	3636BR	3636NC	3636NK3	3636NS
36x48	910x1219	23	10.4	3648BR	3648NC	3648NK3	3648NS
36x60	910x1524	29	13.1	3660BR	3660NC	3660NK3	3660NS
36x72	910x1829	34 1/2	15.4	3672BR	3672NC	3672NK3	3672NS

Note: With 14" (355mm) shelving, stationary units taller than 63" (1600mm) must be properly fastened to the floor or wall using Metro foot plates or wall brackets.  
 Note: The actual length of the shelves is 1/8" (3.2mm) shorter than the nominal dimension shown. The actual depth of the shelves is 1/8" (3.2mm) greater than the nominal dimension shown.  
 Note: Metroseal 3 is not cart-washable.  
 Note: Super Erecta wire shelves up to 48" (1219mm) long have a weight capacity of 800 lbs. (363kg) per shelf evenly distributed. Shelves longer than 48" (1219mm) have a weight capacity of 600 lbs. (272kg) per shelf evenly distributed.

SiteSelect™ Posts

— 10.01a 10.10a

Stationary Super Erecta® SiteSelect posts are fitted with adjustable leveling bolts to compensate for uneven surfaces. Mobile posts come without leveling bolt assembly to accommodate stem casters. Special length posts are available.†

STATIONARY				
Height* (in.) (mm)	Approx. Pkd. Wt. (lbs.) (kg)	Cat. No. Chrome	Cat. No. Metroseal 3 with Microban®	Cat. No. Stainless
7 1/2	191	1/2 0.3	7P	7PK3
14 1/2	370	1 0.5	13P	13PK3
27 1/2	699	1 3/4 0.75	27P	27PK3
34 1/2	875	2 0.9	33P	33PK3
54 9/16	1385	3 1.4	54P	54PK3
62 9/16	1590	3 1/2 1.6	63P	63PK3
74 5/8	1895	4 1.8	74P	74PK3
86 5/8	2200	5 2.3	86P	86PK3
96 5/8	2454	5 1/2 2.5	***96P	

\*Height includes leveling bolt and cap.  
 \*\*Stainless stationary post includes stainless leveling bolt.  
 \*\*\*96P should not be used on units less than 24" (610mm) deep. Consult Metro Engineering for alternate recommendations.

†Note: Special length posts are available, priced at next higher length plus a cutting charge of \$7.00. Post lengths to be specified as cut to a round number, ie: 74P cut to 69" (1753mm) ... This will result in an overall post height with adjustment of 69 3/8" (1762mm) to 69 5/8" (1775mm).

MOBILE				
Approx. Pkd. Wt. (lbs.) (kg)	Cat. No. Plated	Cat. No. Metroseal 3 with Microban®	Cat. No. Stainless	
1 0.5	13UP	13UPK3	13UPS	
1 3/4 0.75	27UP	27UPK3	27UPS	
2 0.9	33UP	33UPK3	33UPS	
3 1.4	54UP	54UPK3	54UPS	
3 1/2 1.6	63UP	63UPK3	63UPS	
3 3/4 1.7		70UPK3		
4 1.8	74UP	74UPK3	74UPS	
4.5 2.0	86UP	86UPK3	86UPS	

These posts come without leveling bolt assembly to accommodate stem casters.  
 Casters for mobile applications can be found on pages 50 & 51.

Indicates antimicrobial product.

Designer Color Shelving — 10.14

Available in a wide spectrum of colors that complement any decor.

Width/Length (in.) (mm)	Approx. Pkd. Wt. (lbs.) (kg)	STANDARD COLORS			DESIGNER COLORS			
		Cat. No. Black	Cat. No. White	Cat. No. Smoked Glass	Cat. No. Flame	Cat. No. Designer Colors*		
14x24	355x610	6	2.7	1424NBL	1424NW	1424-DSG	1424NF	1424N-D
14x30	355x760	7	3.2	1430NBL	1430NW	1430-DSG	1430NF	1430N-D
14x36	355x914	8	3.6	1436NBL	1436NW	1436-DSG	1436NF	1436N-D
14x42	355x1066	9½	4.3	1442NBL	1442NW	1442-DSG	1442NF	1442N-D
14x48	355x1219	10½	4.7	1448NBL	1448NW	1448-DSG	1448NF	1448N-D
14x60	355x1524	14	6.3	1460NBL	1460NW	1460-DSG	1460NF	1460N-D
14x72	355x1829	17	7.7	1472NBL	1472NW	1472-DSG	1472NF	1472N-D
18x18	457x457	6	2.7	1818NBL	1818NW	1818-DSG	1818NF	1818N-D
18x24	457x610	7	3.2	1824NBL	1824NW	1824-DSG	1824NF	1824N-D
18x30	457x760	8	3.6	1830NBL	1830NW	1830-DSG	1830NF	1830N-D
18x36	457x914	9½	4.3	1836NBL	1836NW	1836-DSG	1836NF	1836N-D
18x42	457x1066	11	5.0	1842NBL	1842NW	1842-DSG	1842NF	1842N-D
18x48	457x1219	12	5.4	1848NBL	1848NW	1848-DSG	1848NF	1848N-D
18x54	457x1370	14½	6.6	1854NBL	1854NW	1854-DSG	1854NF	1854N-D
18x60	457x1524	17	7.7	1860NBL	1860NW	1860-DSG	1860NF	1860N-D
18x72	457x1829	20	9.1	1872NBL	1872NW	1872-DSG	1872NF	1872N-D
21x24	530x610	8	3.6	2124NBL	2124NW	2124-DSG	2124NF	2124N-D
21x30	530x760	9	4.1	2130NBL	2130NW	2130-DSG	2130NF	2130N-D
21x36	530x914	11	5.0	2136NBL	2136NW	2136-DSG	2136NF	2136N-D
21x42	530x1066	12	5.4	2142NBL	2142NW	2142-DSG	2142NF	2142N-D
21x48	530x1219	14	6.4	2148NBL	2148NW	2148-DSG	2148NF	2148N-D
21x54	530x1370	16	7.3	2154NBL	2154NW	2154-DSG	2154NF	2154N-D
21x60	530x1524	18	8.2	2160NBL	2160NW	2160-DSG	2160NF	2160N-D
21x72	530x1829	24	10.9	2172NBL	2172NW	2172-DSG	2172NF	2172N-D
24x24	610x610	9	4.1	2424NBL	2424NW	2424-DSG	2424NF	2424N-D
24x30	610x760	11	5.0	2430NBL	2430NW	2430-DSG	2430NF	2430N-D
24x36	610x914	13	5.9	2436NBL	2436NW	2436-DSG	2436NF	2436N-D
24x42	610x1066	15	6.8	2442NBL	2442NW	2442-DSG	2442NF	2442N-D
24x48	610x1219	16	7.3	2448NBL	2448NW	2448-DSG	2448NF	2448N-D
24x54	610x1370	19	8.6	2454NBL	2454NW	2454-DSG	2454NF	2454N-D
24x60	610x1524	21	9.5	2460NBL	2460NW	2460-DSG	2460NF	2460N-D
24x72	610x1829	26	11.8	2472NBL	2472NW	2472-DSG	2472NF	2472N-D

Note: White epoxy Super Erecta shelves come with white split sleeves.  
 Note: All Black, Smoked Glass and Designer Super Erecta shelves come with black split sleeves.  
 Note: Black shelving is NSF listed. White, Smoked Glass, and Designer Colors are not NSF listed.

Posts — 10.14

Height* (in.) (mm)	Approx. Pkd. Wt. (lbs.) (kg)	STATIONARY						
		Cat. No. Black	Cat. No. White	Cat. No. Smoked Glass	Cat. No. Flame	Cat. No. Designer Colors*		
7½	191	½	0.3	7PBL	7PW	7P-DSG	7PF	7P-D
14½	370	1	0.5	13PBL	13PW	13P-DSG	13PF	13P-D
27½	699	1¾	0.75	27PBL	27PW	27P-DSG	27PF	27P-D
34½	875	2	0.9	33PBL	33PW	33P-DSG	33PF	33P-D
54 <sup>9</sup> / <sub>16</sub>	1385	3	1.4	54PBL	54PW	54P-DSG	54PF	54P-D
62 <sup>9</sup> / <sub>16</sub>	1590	3½	1.6	63PBL	63PW	63P-DSG	63PF	63P-D
74 <sup>5</sup> / <sub>8</sub>	1895	4	1.8	74PBL	74PW	74P-DSG	74PF	74P-D
86 <sup>5</sup> / <sub>8</sub>	2200	5	2.3	86PBL	86PW	86P-DSG	86PF	86P-D

Approx. Pkd. Wt. (lbs.) (kg)	MOBILE (FOR STEM CASTERS)				
	Cat. No. Black	Cat. No. White	Cat. No. Smoked Glass	Cat. No. Flame	Cat. No. Designer Colors*
—	—	—	—	—	—
—	—	—	—	—	—
1¾	0.75	27UPBL	27UPW	27UP-DSG	27UPF 27UP-D
2	0.9	33UPBL	33UPW	33UP-DSG	33UPF 33UP-D
3	1.4	54UPBL	54UPW	54UP-DSG	54UPF 54UP-D
3½	1.6	63UPBL	63UPW	63UP-DSG	63UPF 63UP-D
4	1.8	74UPBL	74UPW	74UP-DSG	74UPF 74UP-D
4.5	2.0	86UPBL	86UPW	86UP-DSG	86UPF 86UP-D

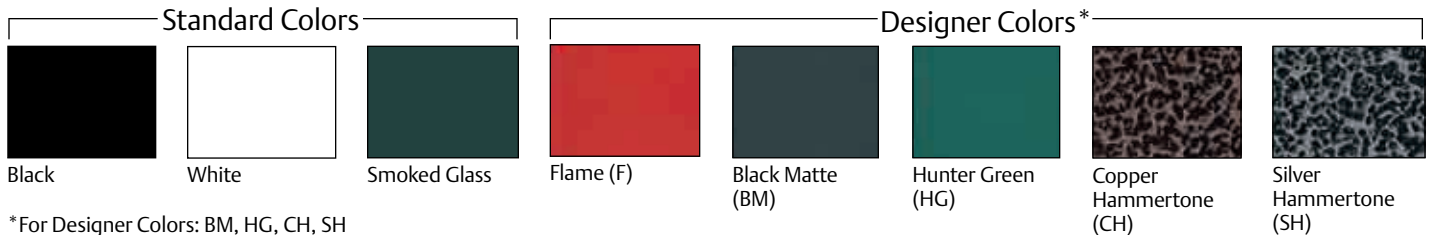

\*For Designer Colors: BM, HG, CH, SH

\*To order a Designer Color, add the appropriate color suffix to the desired catalog numbers above.

Example: 18" x 36" (457 x 914mm) Hunter Green Shelf = 1836N-DHG  
 74" (1880mm) stationary Hunter Green Post = 74P-DHG.



Shelving Starter and Add-On Units

Save time and money by eliminating adjacent posts and replacing with “S” hooks.

- **Starter Units** consist of four posts and indicated number of Super Erecta shelves.
- **Add-On Units** consist of two posts, indicated number of shelves, and two “S” Hooks per shelf, for attaching shelf to adjacent unit.



Replacement “S” Hook  
2 are required for each storage level.  
Cat. No. **9995Z**

For additional wire shelves, order from page 42.



Security “S” Hook  
2 are required for each storage level.  
Chrome. Cat. No. **H9995C**  
Black. Cat. No. **H9995B**

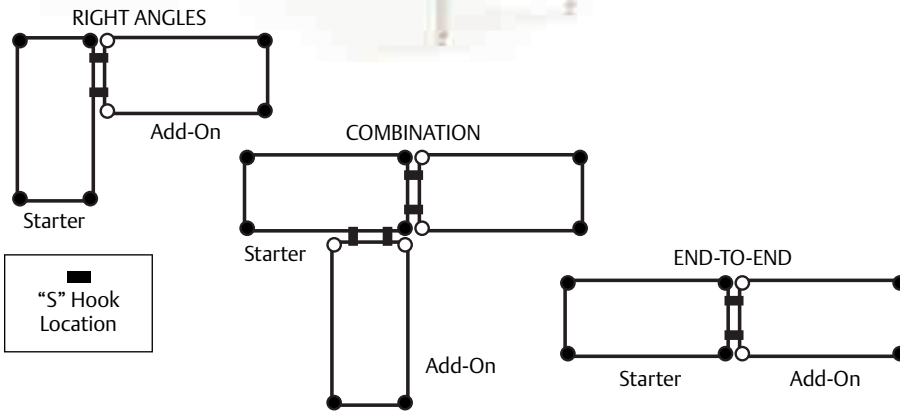

Shelving Starter and Add-On Units — Easy Order Guide

4 Shelves 63" (1600mm) Posts (63P)		Chrome-Plated						5 Shelves 74" (1880mm) Posts (74P)		Chrome-Plated					
		18" (457mm) Wide		21" (530mm) Wide		24" (610mm) Wide		18" (457mm) Wide		21" (530mm) Wide		24" (610mm) Wide			
		Starter	Add-On	Starter	Add-On	Starter	Add-On	Starter	Add-On	Starter	Add-On	Starter	Add-On		
<b>24"</b> (610mm)	Cat. No.	<b>N316C</b>	<b>AN316C</b>	<b>N416C</b>	<b>AN416C</b>	<b>N516C</b>	<b>AN516C</b>	<b>5N317C</b>	<b>5AN317C</b>	<b>5N417C</b>	<b>5AN417C</b>	<b>5N517C</b>	<b>5AN517C</b>		
<b>Long</b>	<b>Wt. lbs. (kg)</b>	42 (19)	35 (16)	46 (21)	39 (18)	50 (23)	43 (20)	51 (23)	43 (20)	57 (26)	48 (22)	62 (28)	53 (24)		
<b>30"</b> (760mm)	Cat. No.	<b>N326C</b>	<b>AN326C</b>	<b>N426C</b>	<b>AN426C</b>	<b>N526C</b>	<b>AN526C</b>	<b>5N327C</b>	<b>5AN327C</b>	<b>5N427C</b>	<b>5AN427C</b>	<b>5N527C</b>	<b>5AN527C</b>		
<b>Long</b>	<b>Wt. lbs. (kg)</b>	47 (21)	40 (18)	52 (24)	45 (20)	57 (26)	50 (23)	58 (26)	50 (23)	64 (29)	56 (25)	71 (32)	62 (28)		
<b>36"</b> (914mm)	Cat. No.	<b>N336C</b>	<b>AN336C</b>	<b>N436C</b>	<b>AN436C</b>	<b>N536C</b>	<b>AN536C</b>	<b>5N337C</b>	<b>5AN337C</b>	<b>5N437C</b>	<b>5AN437C</b>	<b>5N537C</b>	<b>5AN537C</b>		
<b>Long</b>	<b>Wt. lbs. (kg)</b>	53 (24)	46 (21)	59 (27)	52 (24)	65 (30)	58 (26)	65 (29)	57 (26)	73 (33)	65 (29)	81 (37)	73 (33)		
<b>42"</b> (1066mm)	Cat. No.	<b>N346C</b>	<b>AN346C</b>	<b>N446C</b>	<b>AN446C</b>	<b>N546C</b>	<b>AN546C</b>	<b>5N347C</b>	<b>5AN347C</b>	<b>5N447C</b>	<b>5AN447C</b>	<b>5N547C</b>	<b>5AN547C</b>		
<b>Long</b>	<b>Wt. lbs. (kg)</b>	57 (26)	50 (23)	65 (29)	58 (26)	72 (33)	65 (29)	70 (32)	62 (28)	81 (37)	73 (33)	89 (40)	81 (37)		
<b>48"</b> (1219mm)	Cat. No.	<b>N356C</b>	<b>AN356C</b>	<b>N456C</b>	<b>AN456C</b>	<b>N556C</b>	<b>AN556C</b>	<b>5N357C</b>	<b>5AN357C</b>	<b>5N457C</b>	<b>5AN457C</b>	<b>5N557C</b>	<b>5AN557C</b>		
<b>Long</b>	<b>Wt. lbs. (kg)</b>	63 (29)	56 (25)	71 (32)	64 (29)	79 (36)	72 (33)	78 (35)	70 (32)	88 (40)	80 (36)	98 (44)	90 (41)		
<b>60"</b> (1524mm)	Cat. No.	<b>N366C</b>	<b>AN366C</b>	<b>N466C</b>	<b>AN466C</b>	<b>N566C</b>	<b>AN566C</b>	<b>5N367C</b>	<b>5AN367C</b>	<b>5N467C</b>	<b>5AN467C</b>	<b>5N567C</b>	<b>5AN567C</b>		
<b>Long</b>	<b>Wt. lbs. (kg)</b>	82 (31)	75 (34)	88 (40)	81 (37)	98 (44)	91 (41)	102 (46)	93 (42)	109 (49)	101 (46)	122 (55)	113 (51)		
<b>72"</b> (1829mm)	Cat. No.	<b>N376C</b>	<b>AN376C</b>	<b>N476C</b>	<b>AN476C</b>	<b>N576C</b>	<b>AN576C</b>	<b>5N377C</b>	<b>5AN377C</b>	<b>5N477C</b>	<b>5AN477C</b>	<b>5N577C</b>	<b>5AN577C</b>		
<b>Long</b>	<b>Wt. lbs. (kg)</b>	94 (43)	87 (39)	98 (44)	92 (42)	120 (54)	113 (51)	117 (53)	108 (49)	122 (55)	113 (51)	149 (68)	141 (64)		



# SUPER ERECTA® STARTER AND ADD-ON UNITS

## Shelving Starter and Add-On Units – Easy Order Guide (continued)

4 Shelves 63" (1600mm) Posts (63P)		Super Erecta Brite™						5 Shelves 74" (1880mm) Posts (74P)		Super Erecta Brite™					
		18" (457mm) Wide Starter Add-On		21" (530mm) Wide Starter Add-On		24" (610mm) Wide Starter Add-On		18" (457mm) Wide Starter Add-On		21" (530mm) Wide Starter Add-On		24" (610mm) Wide Starter Add-On			
24" (610mm)	Cat. No.	N316BR	AN316BR	N416BR	AN416BR	N516BR	AN516BR	5N317BR	5AN317BR	5N417BR	5AN417BR	5N517BR	5AN517BR		
Long	Wt. lbs. (kg)	42 (19)	35 (16)	46 (21)	39 (18)	50 (23)	43 (20)	51 (23)	43 (20)	57 (26)	48 (22)	62 (28)	53 (24)		
30" (760mm)	Cat. No.	N326BR	AN326BR	N426BR	AN426BR	N526BR	AN526BR	5N327BR	5AN327BR	5N427BR	5AN427BR	5N527BR	5AN527BR		
Long	Wt. lbs. (kg)	47 (21)	40 (18)	52 (24)	45 (20)	57 (26)	50 (23)	58 (26)	50 (23)	64 (29)	56 (25)	71 (32)	62 (28)		
36" (914mm)	Cat. No.	N336BR	AN336BR	N436BR	AN436BR	N536BR	AN536BR	5N337BR	5AN337BR	5N437BR	5AN437BR	5N537BR	5AN537BR		
Long	Wt. lbs. (kg)	53 (24)	46 (21)	59 (27)	52 (24)	65 (30)	58 (26)	65 (29)	57 (26)	73 (33)	65 (29)	81 (37)	73 (33)		
42" (1066mm)	Cat. No.	N346BR	AN346BR	N446BR	AN446BR	N546BR	AN546BR	5N347BR	5AN347BR	5N447BR	5AN447BR	5N547BR	5AN547BR		
Long	Wt. lbs. (kg)	57 (26)	50 (23)	65 (29)	58 (26)	72 (33)	65 (29)	70 (32)	62 (28)	81 (37)	73 (33)	89 (40)	81 (37)		
48" (1219mm)	Cat. No.	N356BR	AN356BR	N456BR	AN456BR	N556BR	AN556BR	5N357BR	5AN357BR	5N457BR	5AN457BR	5N557BR	5AN557BR		
Long	Wt. lbs. (kg)	63 (29)	56 (25)	71 (32)	64 (29)	79 (36)	72 (33)	78 (35)	70 (32)	88 (40)	80 (36)	98 (44)	90 (41)		
60" (1524mm)	Cat. No.	N366BR	AN366BR	N466BR	AN466BR	N566BR	AN566BR	5N367BR	5AN367BR	5N467BR	5AN467BR	5N567BR	5AN567BR		
Long	Wt. lbs. (kg)	82 (31)	75 (34)	88 (40)	81 (37)	98 (44)	91 (41)	102 (46)	93 (42)	109 (49)	101 (46)	122 (55)	113 (51)		
72" (1829mm)	Cat. No.	N376BR	AN376BR	N476BR	AN476BR	N576BR	AN576BR	5N377BR	5AN377BR	5N477BR	5AN477BR	5N577BR	5AN577BR		
Long	Wt. lbs. (kg)	94 (43)	87 (39)	98 (44)	92 (42)	120 (54)	113 (51)	117 (53)	108 (49)	122 (55)	113 (51)	149 (68)	141 (64)		

## Shelving Starter and Add-On Units – Easy Order Guide (continued)

4 Shelves 63" (1600mm) Posts (63PK3)		Metroseal 3 with Microban®						5 Shelves 74" (1880mm) Posts (74PK3)		Metroseal 3 with Microban®					
		18" (457mm) Wide Starter Add-On		21" (530mm) Wide Starter Add-On		24" (610mm) Wide Starter Add-On		18" (457mm) Wide Starter Add-On		21" (530mm) Wide Starter Add-On		24" (610mm) Wide Starter Add-On			
24" (610mm)	Cat. No.	N316K3	AN316K3	N416K3	AN416K3	N516K3	AN516K3	5N317K3	5AN317K3	5N417K3	5AN417K3	5N517K3	5AN517K3		
Long	Wt. lbs. (kg)	42 (19)	35 (16)	46 (21)	39 (18)	50 (23)	43 (20)	51 (23)	43 (20)	57 (26)	48 (22)	62 (28)	53 (24)		
30" (760mm)	Cat. No.	N326K3	AN326K3	N426K3	AN426K3	N526K3	AN526K3	5N327K3	5AN327K3	5N427K3	5AN427K3	5N527K3	5AN527K3		
Long	Wt. lbs. (kg)	47 (21)	40 (18)	52 (24)	45 (20)	57 (26)	50 (23)	58 (26)	50 (23)	64 (29)	56 (25)	71 (32)	62 (28)		
36" (914mm)	Cat. No.	N336K3	AN336K3	N436K3	AN436K3	N536K3	AN536K3	5N337K3	5AN337K3	5N437K3	5AN437K3	5N537K3	5AN537K3		
Long	Wt. lbs. (kg)	53 (24)	46 (21)	59 (27)	52 (24)	65 (30)	58 (26)	65 (29)	57 (26)	73 (33)	65 (29)	81 (37)	73 (33)		
42" (1066mm)	Cat. No.	N346K3	AN346K3	N446K3	AN446K3	N546K3	AN546K3	5N347K3	5AN347K3	5N447K3	5AN447K3	5N547K3	5AN547K3		
Long	Wt. lbs. (kg)	57 (26)	50 (23)	65 (29)	58 (26)	72 (33)	65 (29)	70 (32)	62 (28)	81 (37)	73 (33)	89 (40)	81 (37)		
48" (1219mm)	Cat. No.	N356K3	AN356K3	N456K3	AN456K3	N556K3	AN556K3	5N357K3	5AN357K3	5N457K3	5AN457K3	5N557K3	5AN557K3		
Long	Wt. lbs. (kg)	63 (29)	56 (25)	71 (32)	64 (29)	79 (36)	72 (33)	78 (35)	70 (32)	88 (40)	80 (36)	98 (44)	90 (41)		
60" (1524mm)	Cat. No.	N366K3	AN366K3	N466K3	AN466K3	N566K3	AN566K3	5N367K3	5AN367K3	5N467K3	5AN467K3	5N567K3	5AN567K3		
Long	Wt. lbs. (kg)	82 (31)	75 (34)	88 (40)	81 (37)	98 (44)	91 (41)	102 (46)	93 (42)	109 (49)	101 (46)	122 (55)	113 (51)		
72" (1829mm)	Cat. No.	N376K3	AN376K3	N476K3	AN476K3	N576K3	AN576K3	5N377K3	5AN377K3	5N477K3	5AN477K3	5N577K3	5AN577K3		
Long	Wt. lbs. (kg)	94 (43)	87 (39)	98 (44)	92 (42)	120 (54)	113 (51)	117 (53)	108 (49)	122 (55)	113 (51)	149 (68)	141 (64)		

Add-on units with "S" hooks can only be attached to shelves supported by two or more posts.

✓ Indicates antimicrobial product.



Convenience Pak unit in Chrome finish

Super Erecta® Convenience Pak™ — 10.03

- Providing a complete shelving unit in a single box, Convenience Pak shelving is the easy-to-order alternative to separate shelving components.
- Available in Super Erecta Brite, chrome and Metroseal 3 finishes.

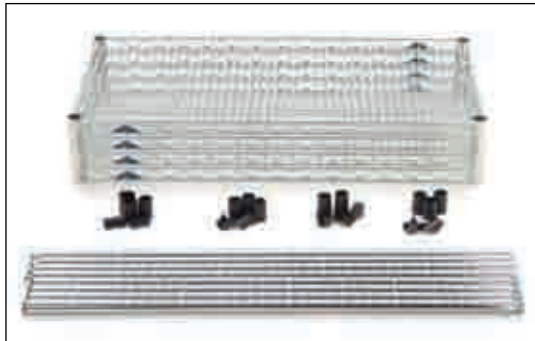

Unassembled Convenience Pak™  
Each pack includes four shelves with split sleeves and four split posts with threaded connectors and leveling feet.

Width/Length/Height (in.)		Approx. Pkd. Wt. (lbs.) (kg)		Cat. No. Super Erecta Brite	Cat. No. Chrome	Cat. No. Metroseal 3 with Microban®
18x36x74 <sup>1</sup> / <sub>2</sub>	457x914x1890	51	23	EZ1836BR-4	EZ1836NC-4	EZ1836NK3-4
18x48x74 <sup>1</sup> / <sub>2</sub>	457x1219x1890	63	28.5	EZ1848BR-4	EZ1848NC-4	EZ1848NK3-4
18x60x74 <sup>1</sup> / <sub>2</sub>	457x1524x1890	82	37	EZ1860BR-4	EZ1860NC-4	EZ1860NK3-4
24x36x74 <sup>1</sup> / <sub>2</sub>	610x914x1890	66	30	EZ2436BR-4	EZ2436NC-4	EZ2436NK3-4
24x48x74 <sup>1</sup> / <sub>2</sub>	610x1219x1890	76	34.5	EZ2448BR-4	EZ2448NC-4	EZ2448NK3-4
24x60x74 <sup>1</sup> / <sub>2</sub>	610x1524x1890	102	46	EZ2460BR-4	EZ2460NC-4	EZ2460NK3-4

Heavy-Duty Dunnage Shelves — 10.45

Enhance the weight-bearing capacity of your system.

- 36" (914mm) shelf holds 1,600 pounds (725kg) (uniformly distributed); 48" (1219mm) shelves carry up to 1,300 pounds (590kg); 60" (1524mm) shelves bear up to 1,000 pounds (453kg).
- Removable wire mat: Lifts off for easy cleaning. <sup>5</sup>/<sub>16</sub>" (7.9mm) diameter wire.
- Support frames: 1" (25mm) square tubing.

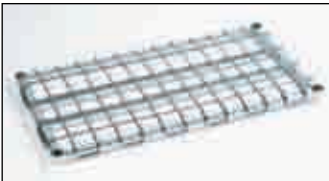

Dunnage Shelf

Width/Length (in.)		Approx. Pkd. Wt. (lbs.) (kg)		Cat. No. Chrome	Cat. No. Metroseal 3 with Microban®	Cat. No. Stainless
18x24	457x610	14	6.3	1824DRC	1824DRK3	—
18x30	457x760	18	8.1	1830DRC	1830DRK3	—
18x36	457x914	21	9.4	1836DRC	1836DRK3	1836DRS
18x48	457x1219	28	12.6	1848DRC	1848DRK3	1848DRS
18x60	457x1524	34	15.3	1860DRC	1860DRK3	1860DRS
24x24	610x610	16	7.2	2424DRC	2424DRK3	—
24x30	610x760	20	9.0	2430DRC	2430DRK3	—
24x36	610x914	24	10.8	2436DRC	2436DRK3	2436DRS
24x48	610x1219	30	13.5	2448DRC	2448DRK3	2448DRS
24x60	610x1524	37	16.6	2460DR	2460DRK3	2460DRS

**Important:** In stationary shelving, stability decreases as the ratio of height to width increases and when heavier loads are placed on upper shelves. Shelving stability is attained by keeping units as wide and low as possible, and placing heavy loads low on the shelving unit.

Cantilever Shelves — 10.06

Adds convenient space above a storage unit. Drop mat design creates a retaining ledge around the entire 12" (305mm) deep shelf. Remember to order rear posts taller than front posts to accommodate these shelves.



Cantilever Shelves

Length (in.)	Length (mm)	Approx. Pkd. Wt. Each (lbs.) (kg)		Cat. No. Chrome	Cat. No. Black	Cat. No. White	Cat. No. Smoked Glass
24	610	4 <sup>1</sup> / <sub>2</sub>	2.0	1224CSNC	1224CSNBL	1224CSNW	1224CSN-DSG
30	750	5	2.3	1230CSNC	1230CSNBL	1230CSNW	1230CSN-DSG
36	914	5 <sup>3</sup> / <sub>4</sub>	2.6	1236CSNC	1236CSNBL	1236CSNW	1236CSN-DSG
42	1066	6 <sup>3</sup> / <sub>4</sub>	3.1	1242CSNC	1242CSNBL	1242CSNW	1242CSN-DSG
48	1219	7 <sup>3</sup> / <sub>4</sub>	3.5	1248CSNC	1248CSNBL	1248CSNW	1248CSN-DSG
60	1524	9 <sup>1</sup> / <sub>2</sub>	4.3	1260CSNC	1260CSNBL	1260CSNW	1260CSN-DSG

✓ Indicates antimicrobial product.

**Foot Plates — 10.06**

Use to bolt units to the floor, or when a broader, more stable foot is desired.  
Zinc. Cat. No. **9993Z**



Stainless Steel.  
Cat. No. **9993S**

Black. Cat. No. **9993BL**

**Glides — 10.06**

Smooth polymer cover fits over leveling bolt to protect floors.  
Cat. No. **9991P**



**Decorative Leveling Foot — 10.06**

Decorative alternative for post. Compensates for uneven surfaces.  
Chrome. Cat. No. **HDFC**



Black. Cat. No. **HDFB**

**Wall Clamp — 10.06**

- Use to secure a stationary unit to the wall for greater stability. Plated finish.
- Compatible with Super Erecta wire shelves and Super Adjustable Super Erecta wire shelves.



Cat. No. **9984C**

**Post Clamps — 10.06**

Joins units together for maximum strength.  
Zinc-plated. Cat. No. **9994Z**  
Black. Cat. No. **9994BL**



**Basket Shelf — 10.04**

3 1/2" (89mm) deep basket with 400 lb. (182kg) weight capacity. Ideal for containing and displaying smaller items.

(in.)	Size (mm)	Cat. No. Chrome	Cat. No. Black
14x36	355x914	—	<b>DD3448A</b>
14x48	355x1219	—	<b>DD3448B</b>
18x36	457x914	<b>CC9744A</b>	<b>CC9744C</b>
18x48	457x1219	<b>CC9744</b>	<b>CC9744B</b>



Basket Shelf  
(Posts sold separately, see page 42)

**Aluminum Split Sleeves — 10.06**

For high temperature, over the road, or conductive applications. Zinc or stainless steel retainer rings available to secure shelf. One bag required per shelf; 4 pairs per bag.



	Cat. No.
Aluminum Split Sleeves with Zinc Rings	<b>9986Z</b>
Aluminum Split Sleeves with Stainless Rings	<b>9986S</b>

**Replacement Plastic Split Sleeves — 10.06**

One bag required per shelf; 4 pairs per bag.



Black Split Sleeve



White Split Sleeve

	Cat. No.
Black Plastic Split Sleeves	<b>9985</b>
White Plastic Split Sleeves	<b>9985W</b>

**Note:** White post caps and white split sleeves are standard with white designer shelving only.

**Replacement Super Adjustable Kit — 10.06**

Package includes 4 wedges, 4 sleeves, and 4 corner releases.  
Cat. No. **SAKITA2**



\*MICROBAN® and the MICROBAN® symbol are registered trademarks of the Microban Products Company, Huntersville, NC.



Super Erecta Mobile Shelving and Transport Carts

Stem Caster Carts (Standard-Duty Mobile Shelving)

- The most common configuration for mobile shelving.
- They are primarily used for applications where the shelving is periodically moved to clean or to transport goods short distances within a facility.
- The weight capacity of the cart is determined by the casters. Typical configurations range from 600-900 lbs. (272-363kg) total unit capacity.

Dolly Trucks (Heavy-Duty Mobile Shelving)

- Carts configured with dolly bases are recommended for heavier duty applications. The dolly base is shock absorbent and the heavier duty plate casters are designed to withstand abusive conditions.
- Dolly trucks are recommended when the carts must travel longer distances, over thresholds, and/or between facilities on a regular basis.
- Dolly trucks can transport up to 1,000 lbs. (454kg) evenly distributed.

Consult your Metro representative to configure a solution to fit your needs.



Wire Stem Caster Cart

Stem Caster Carts — Wire — 11.01

Open-wire shelf design minimizes dust and increases air circulation and visibility. Casters included.

Overall Height 67<sup>7</sup>/<sub>8</sub>" (1724mm). Carts are configured with 63UP posts.

Shelf Width/Length (in.)	Shelf Width/Length (mm)	Approx. Pkd. Wt. (lbs.) (kg)	Super Erecta Brite Finish		Chrome Finish	
			Two Swivel Two Brake Resilient Rubber Casters	Two Swivel Two Brake Polyurethane Casters	Two Swivel Two Brake Resilient Rubber Casters	Two Swivel Two Brake Polyurethane Casters
18x36	457x914	60 27	N336BBR	N336EBR	N336BC	N336EC
18x48	457x1219	72 32	N356BBR	N356EBR	N356BC	N356EC
18x60	457x1524	88 40	N366BBR	N366EBR	N366BC	N366EC
21x36	530x914	69 31	N436BBR	N436EBR	N436BC	N436EC
21x48	530x1219	81 36	N456BBR	N456EBR	N456BC	N456EC
21x60	530x1524	98 44	N466BBR	N466EBR	N466BC	N466EC
24x36	610x914	76 34	N536BBR	N536EBR	N536BC	N536EC
24x48	610x1219	92 41	N556BBR	N556EBR	N556BC	N556EC
24x60	610x1524	112 51	N566BBR	N566EBR	N566BC	N566EC

Note: Models with Resilient Rubber casters can hold up to 600 lbs. (272kg) evenly distributed. Models with Polyurethane casters can hold up to 900 lbs. (409kg) evenly distributed.

Stem Caster Carts — Solid — 11.10

- Consist of four shelves, posts, plastic split sleeves, donut bumpers and 5" (127mm) poly casters (2 swivel; 2 brake).
- Strong and versatile
- Solid Shelf Stem Caster Carts feature a 1/8" (3mm) raised "ship's edge" around perimeter of shelves to help contain spillage.

With Four Galvanized Flat Shelves and Chrome-Plated Posts

63" (1600mm) Posts — Overall Height 67<sup>7</sup>/<sub>8</sub>" (1724mm)

Shelf Width/Length (in.)	Shelf Width/Length (mm)	Approx. Pkd. Wt. (lbs.) (kg)	Cat. No.
24x36	610x914	100 45	F536EG
24x48	610x1219	124 56	F556EG
24x60	610x1524	152 69	F566EG

Note: Models are designed to hold up to 900lbs. (363kg) evenly distributed.



Solid Stem Caster with galvanized shelves

Super Erecta Trucks — With Super Erecta Chrome Wire Shelves — **11.25**  
63" (1600mm) Plated Posts and Aluminum Dolly

Consists of four shelves, posts, plastic split sleeves, donut bumpers and 5" (127mm), resilient rubber or poly casters as designated.

Shelf Width/Length (in.) (mm)	Approx. Pkd. Wt. (lbs.) (kg)	Catalog Number with Casters		
		Two B5DN Two B5DNB	Two B5P Two B5PB	Two 6P Set BL6P
24x36 610x914	96 43	<b>N536JC</b>	<b>N536LC</b>	<b>N536MC</b>
24x48 610x1219	118 53	<b>N556JC</b>	<b>N556LC</b>	<b>N556MC</b>
24x60 610x1524	142 64	<b>N566JC</b>	<b>N566LC</b>	<b>N566MC</b>

Overall heights: JC, LC models — 68<sup>7</sup>/<sub>16</sub>" (1739mm), MC models — 70<sup>7</sup>/<sub>16</sub>" (1800mm).

- JC models: Standard swivel plate casters, two with brake; resilient rubber tread.
- LC models: Standard swivel plate casters, two with brake; polyurethane tread.
- MC models: Larger plate casters; two swivel; one swivel/brake set; polyurethane tread.

**Metro Tip:**  
In applications where thresholds are frequently encountered, Metro Super Erecta Trucks provide durability and increased stability.



Super Erecta Wire Truck

Slanted Shelf Trucks and Carts — **31.05**

Shelves slope backwards 2" (51mm) to keep items from falling during transport. Standard-duty carts have four poly stem casters. Heavy-duty trucks are dolly mounted.

Width/Length (in.) (mm)	Height (in.) (mm)	No. Shelves	Castors	Description	Approx. Pkd. Wt. (lbs.) (kg)	Cat. No.
24x36 610x914	62 <sup>1</sup> / <sub>16</sub> 1577	3	2-BL6P, 2-6P	Heavy-Duty	140 63	<b>AST35MC</b>
24x48 610x1219	62 <sup>1</sup> / <sub>16</sub> 1577	3	2-BL6P, 2-6P	Heavy-Duty	162 72.4	<b>AST55MC</b>
24x60 610x1524	62 <sup>1</sup> / <sub>16</sub> 1577	3	2-BL6P, 2-6P	Heavy-Duty	187 84.1	<b>AST65MC</b>
24x36 610x914	59 <sup>7</sup> / <sub>8</sub> 1521	3	4-Poly Casters	Standard-Duty	105 47.2	<b>AST35DC</b>
24x48 610x1219	59 <sup>7</sup> / <sub>8</sub> 1521	3	4-Poly Casters	Standard-Duty	125 56.2	<b>AST55DC</b>
24x60 610x1524	59 <sup>7</sup> / <sub>8</sub> 1521	3	4-Poly Casters	Standard-Duty	150 67.5	<b>AST65DC</b>

Additional Slanted Shelves

Width/Length (in.) (mm)	Approx. Pkd. Wt. (lbs.) (kg)	Cat. No. Chrome
24x36 610x914	13 6	<b>SLT2436NC</b>
24x48 610x1219	17 8	<b>SLT2448NC</b>
24x60 610x1524	22 10	<b>SLT2460NC</b>

Handles — **11.40**

Use on corresponding width Super Erecta units to provide additional maneuverability to dolly carts or stem caster carts. Split sleeves included for attaching to cart.

Length (in.) (mm)	Push Handles		Extended Handles	
	Cat. No. Chrome	Cat. No. Stainless	Cat. No. Chrome	Cat. No. Stainless
14 355	<b>PH14NC</b>	<b>PH14NS</b>	<b>EH14NC</b>	<b>EH14NS</b>
18 457	<b>PH18NC</b>	<b>PH18NS</b>	<b>EH18NC</b>	<b>EH18NS</b>
21 530	<b>PH21NC</b>	<b>PH21NS</b>	<b>EH21NC</b>	<b>EH21NS</b>
24 610	<b>PH24NC</b>	<b>PH24NS</b>	<b>EH24NC</b>	<b>EH24NS</b>
30 760	<b>PH30NC</b>		<b>EH30NC</b>	
36 914	<b>PH36NC</b>		<b>EH36NC</b>	

Note: Handles fit unit widths only. Extended handles add 6" (152.4mm) to length of unit.



Push Handle



Extended Handle



Standard-Duty Slanted Shelf Cart



5M 5MB

Rigid stem casters are often ordered two per unit for improved tracking and handling. Rigid caster channels are provided with each two rigid stem casters at no charge.

Stem Casters — 11.20

Use with Super Erecta posts and shelves (see pages 37 and 42) to create a mobile shelving unit to meet your special needs. Stem casters are shipped with donut bumper at no additional charge.

Wheel Diameter (in.) (mm)	Face (in.) (mm)	Load Rating (lbs.) (kg)	Type	Wheel Tread	Temperature Range (Continuous Usage) (Fahrenheit) (Celsius)	Approx. Pkd. Wt. (lbs.) (kg)	Cat. No.
4	102 1/2	12 125 56	Stem/Swivel	Resilient Donut	-30°-160° -34°-74°	1 1/2 0.6	4LD
5	127 1/2	12 125 56	Stem/Swivel	Resilient Donut	-30°-160° -34°-74°	2 0.9	5LD
5	127 1/4	32 200 90	Stem/Swivel	Resilient, Flat	-30°-160° -34°-74°	2 1/2 1.1	5M
5	127 1/4	32 200 90	Stem/Brake	Resilient, Flat	-30°-160° -34°-74°	2 5/8 1.2	5MB
5	127 1/4	32 200 90	Stem/Rigid	Resilient, Flat	-30°-160° -34°-74°	3 1/2 1.5	5MR
5	127 1/4	32 250 113	Stem/Swivel	High Modulus Donut	-40°-180° -40°-82°	2 1/2 1.1	5MDA
5	127 1/4	32 250 113	Stem/Brake	High Modulus Donut	-40°-180° -40°-82°	2 5/8 1.2	5MDBA
5	127 1/4	32 250 113	Stem/Rigid	High Modulus Donut	-40°-180° -40°-82°	2 3/8 1.1	5MDRA
5	127 1/4	32 300 135	Stem/Swivel	Polyurethane, Flat	-30°-180° -34°-82°	2 1/8 0.9	5MP
5	127 1/4	32 300 135	Stem/Brake	Polyurethane, Flat	-30°-180° -34°-82°	2 1/4 1	5MPB
5	127 1/4	32 300 135	Stem/Rigid	Polyurethane, Flat	-30°-180° -34°-82°	2 0.9	5MPR
6	152 1/2	38 400 182	Stem/Swivel	Polyurethane, Flat	-30°-180° -34°-82°	2 1/4 1.1	6MP
6	152 1/2	38 400 182	Stem/Brake	Polyurethane, Flat	-30°-180° -34°-82°	2 1/2 0.9	6MPB
6	152 1/2	38 400 182	Stem/Rigid	Polyurethane, Flat	-30°-180° -34°-82°	2 1/4 1	6MPR

Note 1: Rigid casters are held in position by a connecting channel. When ordering rigid casters, shelf width must be known.  
 Note 2: Load Height for all 5M and 5MP casters — 6<sup>3</sup>/<sub>32</sub>" ± 1/16" (155 ± 1.5mm).  
 Note 3: Load Height for 4LD caster — 4<sup>5</sup>/<sub>16</sub>" ± 1/16" (118 ± 1.5mm).  
 Note 4: Load Height for 5LD caster — 5<sup>5</sup>/<sub>16</sub>" ± 1/16" (143 ± 1.5mm).  
 Note 5: Brakes are foot-operated.



5PC 5PCB

Polymer Casters — 11.20

Innovative polymer stem casters offer corrosion resistance and enhanced durability. Appropriate for all medium-duty mobile applications. Donut bumpers included.

- All-polymer horn, stainless steel axle and hardware.
- 5" (127mm) diameter polyurethane wheel, sleeve-style axle bearing and an optional toe-operated brake mechanism.
- Polyurethane, flat wheel tread.

Wheel Diameter (in.) (mm)	Face (in.) (mm)	Load Rating (lbs.) (kg)	Type	Temperature Range (Continuous Usage) (Fahrenheit) (Celsius)	Approx. Pkd. Wt. (lbs.) (kg)	Cat. No.	Cat. No. Antimicrobial
5	127 1/4	32 300 135	Stem/Swivel	-20°-120° -29°-49°	2 0.9	5PC	5PCM
5	127 1/4	32 300 135	Stem/Brake	-20°-120° -29°-49°	2 0.9	5PCB	5PCBM
5	127 1/4	32 300 135	Stem/Rigid	-20°-120° -29°-49°	2 0.9	5PCR	

Note 1: Rigid casters are held in place by a connecting channel. When ordering, shelf depth must be provided.



5MDGSA

Stainless Steel Cart-Washable Stem Casters — 11.20

Stem casters are shipped with donut bumpers at no extra charge.

Wheel Diameter (in.) (mm)	Face (in.) (mm)	Load Rating (lbs.) (kg)	Type	Wheel Tread	Temperature Range (Continuous Usage) (Fahrenheit) (Celsius)	Approx. Pkd. Wt. (lbs.) (kg)	Cat. No.
5	127 1/4	32 250 113	Stem/Swivel	High Modulus Donut	-40°-180° -40°-82°	2 1/2 1.1	5MDGSA
5	127 1/4	32 250 113	Stem/Brake	High Modulus Donut	-40°-180° -40°-82°	2 5/8 1.2	5MDBGSA
5	127 1/4	32 250 113	Stem/Rigid	High Modulus Donut	-40°-180° -40°-82°	2 3/8 1.1	5MDRGSA
5	127 1/4	32 300 135	Stem/Swivel	Polyurethane, Flat	-30°-180° -34°-82°	2 1/8 0.9	5MPGSA
5	127 1/4	32 300 135	Stem/Brake	Polyurethane, Flat	-30°-180° -34°-82°	2 1/4 1	5MPBGSA
5	127 1/4	32 300 135	Stem/Rigid	Polyurethane, Flat	-30°-180° -34°-82°	2 0.9	5MPRGSA

Note 1: Rigid casters are held in position by a connecting channel. When ordering rigid casters, shelf width must be known.  
 Note 2: Load Height for all 5MD and 5MP casters — 6<sup>3</sup>/<sub>32</sub>" ± 1/16" (155 ± 1.5mm).  
 Note 3: All casters are grease sealed with zerk fittings in swivel and axle.  
 Note 4: Brakes are foot-operated.



5MHTPB 5MHTNB

High-temperature Autoclave Stem Casters

Indicates antimicrobial product.

Wheel Diameter (in.) (mm)	Face (in.) (mm)	Load Rating (lbs.) (kg)	Type	Wheel Tread	Temperature Range (Continuous Usage) (Fahrenheit) (Celsius)	Approx. Pkd. Wt. (lbs.) (kg)	Cat. No.
5	127 1/2	38 300 135	Stem/Swivel	Polyurethane Flat	-45°-475° -43°-250°	2 1/8 1	5MHTPB
5	127 1/2	38 300 135	Stem/Brake	Polyurethane Flat	-45°-475° -43°-250°	2 1/8 1.3	5MHTPB
5	127 1/2	38 300 135	Stem/Swivel	Polyurethane Flat	-20°-475° -29°-250°	2 2/8 1.1	5MHTN
5	127 1/2	38 300 135	Stem/Brake	Polyurethane Flat	-20°-475° -29°-250°	3 1.4	5MHTNB

Swaged Posts — For cart wash and autoclave applications

Each Type 304 stainless post has an aluminum cap swaged into the top of the post. For use with standard stem casters.



Swaged Post

Description	Dimensions (in.) (mm)		Cat. No.
Stem Caster Post	33	875	33UPS-SW
Stem Caster Post	54	1370	54UPS-SW
Stem Caster Post	63	1600	63UPS-SW

## Donut Bumpers — 11.40

Diameter (in.) (mm)		Height (lbs.) (kg)		Cat. No.
3 1/2	89	3/4	19	9992DB*
5 1/2	140	1 3/16	21	9992N

\*Included with each Super Erecta stem caster as noted on previous page.



Donut Bumper

## Decorative Casters — 10.06

- Black nylon housing with non-marking polymer tread.
- 2 1/2" (63mm) models have threaded stem and attach to stationary shelving posts.
- 4" (100mm) casters include threaded insert for use with mobile posts.



HDC5B      HDC5BB

Type	Diameter (in.) (mm)		Fits Post Type	Cat. No.
Swivel/Brake	2 1/2	63	Stationary	HDC3BB
Swivel	4	100	Mobile	HDC5B
Swivel/Brake	4	100	Mobile	HDC5BB

Castors shipped with post inserts (as shown left) for adaptability to mobile posts.

The following information is to assist you in the selection of the appropriate caster for your specific application. Remember, the selection of the proper caster is determined by the load requirements, the operating environment, and other special conditions.

Wheel Material	Resistance to Oil & Grease	Rollability	Floor Protection	Noise
Resilient Rubber	Low	Fair	Good	Low
Neoprene	High	Good	Good	Low
Polyurethane	High	Good	Good	Moderate
High Modulus Rubber	High	Good	Good	Low
Conductive	Low	Fair	Good	Low

### Caster Tips:

1. The total weight of the equipment and its load should not exceed three times the load rating per caster.
2. Given the same wheel material, the larger the wheel diameter, the greater the load capacity and the better the rollability.
3. Caster mounting patterns affect maneuverability and steering of the equipment.
4. Plate casters generally have wheels of larger diameter and can usually carry more weight and take more abuse than stem casters.
5. Ball bearings and roller bearings in the wheel generally perform better and carry more weight than engineered plastic bearings or sintered metal bearings. Metro stem casters in the 5MP and the 5MDA series have ball bearings in the swivel and the wheel. Most plate casters have ball bearings in the swivel and ball or roller bearings in the wheel.
6. Wheel tread shapes are generally flat, rounded or tapered. Tapered wheels, like donut-shaped wheels, tend to roll more easily. High-modulus donut wheels offer resiliency and mobility, reduce noise, and absorb shock on uneven or rough floors.

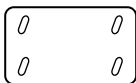

For maneuverability, use 4 swivel casters.

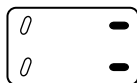

For steering control use 2 swivel and 2 rigid casters.

Additional stem and plate casters, in various sizes, are available.

Made-To-Order Truck Dollies (Aluminum)\* — 11.37

Select the desired dolly size from chart below and combine with desired plate casters found on page 53 to make your corresponding size Super Erecta unit mobile. For example: D1824NCB, four #B5DN = one 18"x24" (457x610mm) aluminum dolly frame with four 5" (127mm) plate swivel casters.



Dolly Frame

**Metro Fact:**

Metro dolly frames and stock truck dollies add 3 1/8" (78mm) to the length of the unit and 3 3/8" (87mm) to the unit width.

Stainless steel frames and staked posts are recommended for heavy-duty applications.

Truck Dolly Frames

Shelf Width/Length (in./mm)		ALUMINUM		STAINLESS	
		Cat. No. with Corner Bumper	Cat. No. with Wraparound Bumper	Cat. No. with Corner Bumper	Cat. No. with Wraparound Bumper
18x24	457x610	D1824NCB	D1824NP	D1824SCB	D1824SP
18x30	457x760	D1830NCB	D1830NP	D1830SCB	D1830SP
18x36	457x914	D1836NCB	D1836NP	D1836SCB	D1836SP
18x42	457x1066	D1842NCB	D1842NP	D1842SCB	D1842SP
18x48	457x1219	D1848NCB	D1848NP	D1848SCB	D1848SP
18x60	457x1524	D1860NCB	D1860NP	D1860SCB	D1860SP
18x72	457x1825	D1872NCB	D1872NP	D1872SCB	D1872SP
21x24	530x610	D2124NCB	D2124NP	D2124SCB	D2124SP
21x30	530x760	D2130NCB	D2130NP	D2130SCB	D2130SP
21x36	530x914	D2136NCB	D2136NP	D2136SCB	D2136SP
21x42	530x1066	D2142NCB	D2142NP	D2142SCB	D2142SP
21x48	530x1219	D2148NCB	D2148NP	D2148SCB	D2148SP
21x60	530x1524	D2160NCB	D2160NP	D2160SCB	D2160SP
21x72	530x1825	D2172NCB	D2172NP	D2172SCB	D2172SP
24x24	610x610	D2424NCB	D2424NP	D2424SCB	D2424SP
24x30	610x760	D2430NCB	D2430NP	D2430SCB	D2430SP
24x36	610x914	D2436NCB	D2436NP	D2436SCB	D2436SP
24x42	610x1066	D2442NCB	D2442NP	D2442SCB	D2442SP
24x48	610x1219	D2448NCB	D2448NP	D2448SCB	D2448SP
24x60	610x1524	D2460NCB	D2460NP	D2460SCB	D2460SP
24x72	610x1825	D2472NCB	D2472NP	D2472SCB	D2472SP

Note 1: Replacement wraparound bumper kits are available. See your Metro representative for details.  
 Note 2: "Made To Order Dollies" are non-returnable.  
 Note 3: Maximum load capacity for dollies is 1,000 lbs. (454kg), depending on caster selection.

Stock Truck Dollies — 11.36

These are aluminum dollies with a single catalog number for frame and casters with wraparound bumper. Use with Super Erecta Shelving and posts to create mobile carts for higher weight capacities. See specific plate caster load ratings (page 53) to determine appropriate stock truck dolly.

Shelf Width/Length (in./mm)	Casters	Cat. No.	Shelf Width/Length (in./mm)	Casters	Cat. No.		
24x36	610x914	Two B5DN/Two B5DNB	D53JN	24x48	610x1219	Two 8P/Two BL8P	D55PN
24x48	610x1219	Two B5DN/Two B5DNB	D55JN	24x60	610x1524	Two 8P/Two BL8P	D56PN
24x60	610x1524	Two B5DN/Two B5DNB	D56JN	24x48	610x1219	Two C8DA/Two C8DSL*	D55PSLN
24x36	610x914	Two 6P/Two BL6P	D53MN	24x60	610x1524	Two C8DA/Two C8DSL*	D56PSLN
24x48	610x1219	Two 6P/Two BL6P	D55MN				
24x60	610x1524	Two 6P/Two BL6P	D56MN				

\*Swivel Lock.  
 Note: Replacement wraparound bumper kits are available. See your Metro representative for details.



Stock Dolly

Staked Posts — For use with Truck Dollies

Each post connects to a truck dolly through the stem receptacle. The stem receptacles are staked into the bottom of these posts to ensure a durable connection in abusive applications.

Height* (in./mm)	Approx. Pkd. Wt. (lbs./kg)	Cat. No. Chrome	Cat. No. Stainless
54 9/16	1385 3 1.4	54P-STKD	54PS-STKD
62 9/16	1590 3 1/2 1.6	63P-STKD	63PS-STKD
74 5/8	1895 4 1.8	74P-STKD	74PS-STKD

\*Height includes leveling bolt and cap.



Staked Post

Pitched Aluminum Dust Cover — 11.37

For "Made-To-Order" dollies, these covers act as a barrier between the floor and the bottom shelf of cart for cleanliness. These covers are factory-assembled and must be ordered with desired dolly frame.

Width/Length (in./mm)	Approx. Pkd. Wt. (lbs./kg)	Cat. No.
24x36	610x914	7 3.2 DCT2436N
24x42	610x1066	7 3.2 DCT2442N
24x48	610x1219	8 3.6 DCT2448N
24x60	610x1524	8 3.6 DCT2460N
24x72	610x1825	8 3.6 DCT2472N



Pitched Aluminum Dust Cover

Plate Casters — 11.37

Use in conjunction with Metro “Made-To-Order” truck dollies to assemble a mobile base appropriate for your needs.

Diameter (in.) (mm)	Wheel Face (in.) (mm)	Load Rating (lbs.) (kg)	Load Weight Each (lbs.) (kg)	Type	Wheel Tread	Cat. No.	
5	125	13/8 35	225 101	21/8 .99	Swivel	Donut Neoprene	<b>B5DN</b>
5	125	13/8 35	225 101	21/4 1	Brake	Donut Neoprene	<b>B5DNB</b>
5	125	13/8 35	225 101	2 .9	Rigid	Donut Neoprene	<b>B5DNR</b>
5	125	11/4 31	300 135	21/8 .99	Swivel	Polyurethane	<b>B5P</b>
5	125	11/4 31	300 135	21/4 1	Brake	Polyurethane	<b>B5PB</b>
5	125	11/4 31	300 135	2 .9	Rigid	Polyurethane	<b>B5PR</b>
6	152	2 51	400 181	8 3.63	Swivel	Hi-Modulus Donut	<b>C6DA</b>
6	152	2 51	400 181	8 3.63	Swivel/Brake	Hi-Modulus Donut	<b>C6DBA</b>
6	152	2 51	400 181	8 3.63	Rigid	Hi-Modulus Donut	<b>C6DRA</b>
6	152	2 51	400 181	8 3.63	Swivel/Lock	Hi-Modulus Donut	<b>C6DSLA</b>
8	203	2 51	450 204	9 4.08	Swivel	Hi-Modulus Donut	<b>C8DA</b>
8	203	2 51	450 204	9 4.08	Swivel/Brake	Hi-Modulus Donut	<b>C8DBA</b>
8	203	2 51	450 204	9 4.08	Rigid	Hi-Modulus Donut	<b>C8DRA</b>
8	203	2 51	450 204	9 4.08	Swivel/Lock	Hi-Modulus Donut	<b>C8DSLA</b>
6	150	2 51	500 225	43/4 2.1	Swivel	Polyurethane	<b>C6P</b>
6	150	2 51	500 225	47/8 2.2	Brake	Polyurethane	<b>C6PB</b>
6	150	2 51	500 225	31/2 1.6	Rigid	Polyurethane	<b>C6PR</b>
6	150	2 51	500 225	5 2.3	Swivel/Lock	Polyurethane	<b>C6PS/L-LH</b>
8	200	2 51	700 315	53/4 2.6	Swivel	Polyurethane	<b>C8P</b>
8	200	2 51	700 315	57/8 2.65	Brake	Polyurethane	<b>C8PB</b>
8	200	2 51	700 315	41/2 2	Rigid	Polyurethane	<b>C8PR</b>
8	200	2 51	700 315	6 2.7	Swivel/Lock	Polyurethane	<b>C8PS/L-LH</b>

Note 1: Brakes are foot-operated.

Note 2: 8" (200mm) casters should not be used on units less than 21" (530mm) wide.

Note 3: Swivel lock casters are set diagonally on the left-hand sides when dolly mounted.

Load Heights: B5 Series — 61/4" (159mm) C6 Series — 71/2" (190mm) 6P Series — 77/8" (200mm)  
 (±1/16") (±1.6mm) C8 Series — 91/2" (241mm) 8P Series — 913/16" (249mm)



B5DNB with Wheel Brake



B5P Polyurethane

See page 51 for additional specifications and appropriate parameters for all types of Metro casters.

Stainless Steel Cart-Washable Plate Casters — 11.37

Wheel Diameter (in.) (mm)	Face (in.) (mm)	Load Rating (lbs.) (kg)	Weight Each (lbs.) (kg)	Type	Wheel Tread	Cat. No.	
5	125	11/4 31	300 135	21/8 .99	Swivel	Polyurethane	<b>B5PGSA</b>
5	125	11/4 31	300 135	21/4 1	Brake	Polyurethane	<b>B5PBGSA</b>
5	125	11/4 31	300 135	2 .9	Rigid	Polyurethane	<b>B5PRGSA</b>
6	150	11/2 38	600 270	43/4 2.1	Swivel	Polyurethane	<b>C6PGSA</b>
6	150	11/2 38	600 270	47/8 2.2	Brake	Polyurethane	<b>C6PBGSA</b>
6	150	11/2 38	600 270	31/2 1.6	Rigid	Polyurethane	<b>C6PRGSA</b>
8	200	11/2 38	800 360	53/4 2.6	Swivel	Polyurethane	<b>C8PGSA</b>
8	200	11/2 38	800 360	57/8 2.65	Brake	Polyurethane	<b>C8PBGSA</b>
8	200	11/2 38	800 360	41/2 2	Rigid	Polyurethane	<b>C8PRGSA</b>

See above notes for important specification information.



B5PGSA

Dolly Adapter Kits for MetroMax i and MetroMax Q

Required when mounting a MetroMax i or MetroMax Q unit to a dolly frame.

Cat. No. **DMK-2X**

General Guidelines for Metro Carts Used in Over-the-Road Applications

For applications where carts are loaded on to or off of trucks for transportation, and/or where thresholds exceeding 3/8" in height are repeatedly encountered:

- A dolly is recommended for maximum useful life.
- Casters of at least 6" diameter are recommended. Consideration should be given to the shock absorbing ability of the caster wheel, but selection will need to be based upon the specifics of the application.
- Aluminum split sleeves and staked posts should be used.

- Weight load should be limited to approximately 750 lbs. depending on the specifics of the application.

Consult your Metro representative with the details of the Over-the-Road application. Each application is unique, and the preceding points are intended only as general guidelines.

**Brake Lock/Swivel Lock Combination Casters — 11.70**

Patented, foot-operated design enables a single pair of casters to serve as swivel, rigid or brake casters. Conveniently positioned on the dolly, not on the wheels, the downward pressure pedals prevent scuffing of shoes.



Brake Lock/Swivel Lock combination casters

- **How It Works**  
Brake lock/swivel lock caster sets are operated by two separate foot pedals. One pedal locks the two wheels in a rigid position or releases them to swivel; the other pedal engages and releases brakes on the same two wheels.
- **Convenient**  
Pedals are on the dolly, not the wheels, making operation more convenient. Downward pressure on the pedals save shoes from scuffing.
- **Casters**  
Long wearing polyurethane. Resists abrasion. Non-marking, shock absorbing. Wheels are available in 6" (152mm) and 8" (203mm) size.
- **Recommended Caster Selection**  
Two swivel casters at one end and brake/swivel lock set at the other end. Other caster combinations can be used, however, including brake/swivel lock sets at both ends. Wraparound bumper recommended.

Type	Wheel Diameter (in. / mm)		Face (in. / mm)		For Use With	Load Rating (lbs. / kg)		Weight (lbs. / kg)		Cat. No.
*Brake/Lock	6	152	2	51	24" (610mm) Deep Dolly and 6P Caster	600	272	7 <sup>1</sup> / <sub>4</sub>	3.3	BL6P24
*Brake/Lock	8	203	2	51	24" (610mm) Deep Dolly and 8P Caster	600	272	9	4.1	BL8P24
Swivel	6	152	2	51	BL6P24 Brake/Lock Set	600	272	5 <sup>1</sup> / <sub>4</sub>	2.3	6P
Rigid	6	152	2	51	6P Swivel Caster	600	272	5	2.26	6PR
Swivel	8	203	2	51	BL8P24 Brake/Lock Set	600	272	6 <sup>1</sup> / <sub>2</sub>	2.9	8P
Rigid	8	203	2	51	8P Swivel Caster	600	272	6	2.7	8PR

\*Above part numbers include the brake/lock mechanism with two casters. Order dolly separately (see page 28). In addition order either two 6P or two 8P casters. Example: (1) D2436NP and (1) BL6P24 or (1) BL8P24 and two 6P or two 8P.

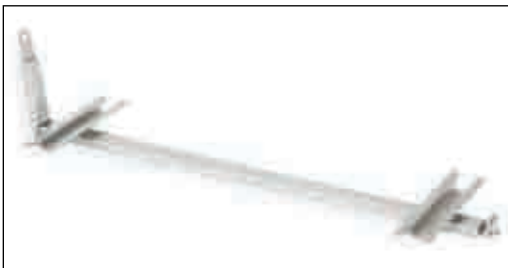

Tow Bar Assembly

**Tow Bar Assembly — 11.70**

Attaches to underside of dolly to facilitate transport of dolly carts in tandem. Must be factory assembled and ordered with desired dolly frame (see page 52).

Length (in.)	Length (mm)	Cat. No.
48	1219	TBA48

**Note:** "C" plate caster must be used with Tow Bar Assembly. Tow Bar Assembly for use with 24" (610mm) units only.

**Note:** Number of carts to be towed, weight on carts, and towing route affect operation of tow bar assembly. **Before ordering, contact your Metro representative.**  
Tow Bar Assembly not appropriate for use with Brake Lock/Swivel Lock system.



Push Handle

**Handles — 11.40**

Use on corresponding width Super Erecta units to provide additional maneuverability to dolly carts or stem caster carts. Split sleeves included for attaching to cart.

Length (in.)	Length (mm)	Push Handles		Extended Handles	
		Cat. No. Chrome	Cat. No. Stainless	Cat. No. Chrome	Cat. No. Stainless
14	355	PH14NC	PH14NS	EH14NC	EH14NS
18	457	PH18NC	PH18NS	EH18NC	EH18NS
21	530	PH21NC	PH21NS	EH21NC	EH21NS
24	610	PH24NC	PH24NS	EH24NC	EH24NS
30	760	PH30NC		EH30NC	
36	914	PH36NC		EH36NC	

**Note:** Handles fit unit widths only. Extended handles add 6" (152.4mm) to length of unit.



Extended Handle

Shelf Dividers for Super Erecta Shelves — 10.04

Keep shelf contents orderly with these 8" (203mm) high, pressure-fit dividers.

Shelf Width (in.)	Shelf Width (mm)	Approx. Pkd. Wt. (lbs.) (kg)		Cat. No. Plated	Cat. No. Black	Cat. No. White	Cat. No. Smoked Glass
14	355	1.8	0.8	DD14C	DD14BL	DD14W	DD14-DSG
18	457	2.25	1.0	DD18C	DD18BL	DD18W	DD18-DSG
21	530	2.5	1.1	DD21C	DD21BL	DD21W	DD21-DSG
24	610	2.75	1.3	DD24C	DD24BL	DD24W	DD24-DSG
30	760	3.25	1.5	DD30C	DD30BL	DD30W	DD30-DSG
36	914	3.75	1.7	DD36C	DD36BL	DD36W	DD36-DSG



Shelf Divider for Super Erecta Shelves

Shelf Width (in.)	Shelf Width (mm)	Approx. Pkd. Wt. (lbs.) (kg)		Cat. No. Metroseal 3 with Microban®	Cat. No. Stainless	Cat. No. Designer Colors
14	355	1.8	0.8	DD14K3	DD14S	DD14-D
18	457	2.25	1.0	DD18K3	DD18S	DD18-D
21	530	2.5	1.1	DD21K3	DD21S	DD21-D
24	610	2.75	1.3	DD24K3	DD24S	DD24-D
30	760	3.25	1.5		DD30S	
36	914	3.75	1.7		DD36S	

Universal 8" (203mm) Shelf Dividers — Light Duty — 9.25

Each divider includes a panel and two clips to connect to any Super Erecta or Super Adjustable wire self. Corrosion proof.

Nominal Length (in.)	Nominal Length (mm)	Fits Shelf Depth	Approx. Pkd. Wt. (lbs.) (kg)		Cat. No.
18	457	18", 21" (457, 530mm)	1.3	0.6	MUD18-8
24	610	24" (610mm)	1.6	0.7	MUD24-8

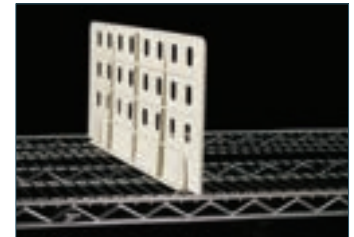

Universal Shelf Divider

Shelf Ledges — Side and Back — 10.04

For stationary or mobile installations, ledges prevent items from protruding or falling from shelves.

1" (25mm) High Ledges

Length (in.)	Length (mm)	Approx. Pkd. Wt. (lbs.) (kg)		Cat. No. Plated	Cat. No. Black	Cat. No. White	Cat. No. Smoked Glass	Cat. No. Stainless	Cat. No. Designer Colors
14	355	0.58	0.25	L14N-1C	L14N-1BL	L14N-1W	L14N-1-DSG	L14N-1S	L14N-1-D
18	457	0.75	0.33	L18N-1C	L18N-1BL	L18N-1W	L18N-1-DSG	L18N-1S	L18N-1-D
21	530	0.75	0.33	L21N-1C	L21N-1BL	L21N-1W	L21N-1-DSG	L21N-1S	L21N-1-D
24	610	1.0	0.45	L24N-1C	L24N-1BL	L24N-1W	L24N-1-DSG	L24N-1S	L24N-1-D
30	760	2.0	0.9	L30N-1C	L30N-1BL	L30N-1W	L30N-1-DSG	L30N-1S	L30N-1-D
36	914	2.5	1.13	L36N-1C	L36N-1BL	L36N-1W	L36N-1-DSG	L36N-1S	L36N-1-D
42	1066	2.75	1.25	L42N-1C	L42N-1BL	L42N-1W	L42N-1-DSG	L42N-1S	L42N-1-D
48	1219	3.5	1.58	L48N-1C	L48N-1BL	L48N-1W	L48N-1-DSG	L48N-1S	L48N-1-D
54	1370	4.4	1.65	L54N-1C	L54N-1BL	L54N-1W	L54N-1-DSG	L54N-1S	L54N-1-D
60	1524	3.75	1.68	L60N-1C	L60N-1BL	L60N-1W	L60N-1-DSG	L60N-1S	L60N-1-D
72	1828	4.0	1.81	L72N-1C	L72N-1BL	L72N-1W	L72N-1-DSG	L72N-1S	L72N-1-D

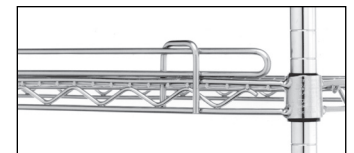

1" (25mm) Ledge



4" (102mm) Ledge

4" (100mm) High Stackable Ledges

Shelf Width (in.)	Shelf Width (mm)	Approx. Pkd. Wt. (lbs.) (kg)		Cat. No. Plated	Cat. No. Black	Cat. No. White	Cat. No. Smoked Glass	Cat. No. Metroseal 3 with Microban®	Cat. No. Stainless	Cat. No. Designer Colors
14	355	0.83	0.36	L14N-4C	L14N-4BL	L14N-4W	L14N-4-DSG	L14N-4K3	L14N-4S	L14N-4-D
18	457	1.5	0.68	L18N-4C	L18N-4BL	L18N-4W	L18N-4-DSG	L18N-4K3	L18N-4S	L18N-4-D
21	530	1.75	0.71	L21N-4C	L21N-4BL	L21N-4W	L21N-4-DSG	L21N-4K3	L21N-4S	L21N-4-D
24	610	2.0	0.9	L24N-4C	L24N-4BL	L24N-4W	L24N-4-DSG	L24N-4K3	L24N-4S	L24N-4-D
30	760	2.25	1.03	L30N-4C	L30N-4BL	L30N-4W	L30N-4-DSG	L30N-4K3	L30N-4S	L30N-4-D
36	914	2.75	1.25	L36N-4C	L36N-4BL	L36N-4W	L36N-4-DSG	L36N-4K3	L36N-4S	L36N-4-D
42	1066	3.25	1.48	L42N-4C	L42N-4BL	L42N-4W	L42N-4-DSG	L42N-4K3	L42N-4S	L42N-4-D
48	1219	3.75	1.68	L48N-4C	L48N-4BL	L48N-4W	L48N-4-DSG	L48N-4K3	L48N-4S	L48N-4-D
54	1370	4.8	1.73	L54N-4C	L54N-4BL	L54N-4W	L54N-4-DSG	L54N-4K3	L54N-4S	L54N-4-D
60	1524	4.0	1.81	L60N-4C	L60N-4BL	L60N-4W	L60N-4-DSG	L60N-4K3	L60N-4S	L60N-4-D
72	1828	5.0	2.25	L72N-4C	L72N-4BL	L72N-4W	L72N-4-DSG	L72N-4K3	L72N-4S	L72N-4-D

Note: Actual ledge length is approximately 1" (25mm) shorter than nominal shelf length/width.



Indicates antimicrobial product.



Enclosure Panel

Enclosure Panels — 10.04 10.30

An efficient way to enclose space for stationary or mobile applications.

- Can be used with Super Erecta® and Super Adjustable wire shelving, and Super Erecta solid shelving.
- Appropriate mounting hardware supplied with each panel for stationary applications.

Width/Height (in.) (mm)		For Nominal Post Height (in.) (mm)		Grid Opening (in.) (mm)		Weight (lbs.) (kg)		Cat. No. Chrome	Cat. No. Stainless
12 <sup>3</sup> / <sub>8</sub> x50 <sup>3</sup> / <sub>4</sub>	313x1289	54	1370	2 <sup>7</sup> / <sub>8</sub> x3 <sup>5</sup> / <sub>8</sub>	73x92	3	1.4	EP35C	EP35S
12 <sup>3</sup> / <sub>8</sub> x59 <sup>3</sup> / <sub>4</sub>	313x1518	63	1600	2 <sup>7</sup> / <sub>8</sub> x3 <sup>5</sup> / <sub>8</sub>	73x92	4	1.8	EP36C	EP36S
12 <sup>3</sup> / <sub>8</sub> x70 <sup>1</sup> / <sub>2</sub>	313x1791	74	1880	2 <sup>7</sup> / <sub>8</sub> x3 <sup>5</sup> / <sub>8</sub>	73x92	6	2.7	EP37C	
18 <sup>3</sup> / <sub>8</sub> x50 <sup>3</sup> / <sub>4</sub>	464x1289	54	1370	3 <sup>3</sup> / <sub>8</sub> x3 <sup>5</sup> / <sub>8</sub>	86x92	5	2.3	EP55C	EP55S
18 <sup>3</sup> / <sub>8</sub> x59 <sup>3</sup> / <sub>4</sub>	464x1518	63	1600	3 <sup>3</sup> / <sub>8</sub> x3 <sup>5</sup> / <sub>8</sub>	86x92	6	2.7	EP56C	EP56S
18 <sup>3</sup> / <sub>8</sub> x70 <sup>1</sup> / <sub>2</sub>	464x1791	74	1800	3 <sup>3</sup> / <sub>8</sub> x3 <sup>5</sup> / <sub>8</sub>	86x92	7	3.2	EP57C	

All panels are 7/8" (22mm) deep.

Note: Units with a solid shelf in the top position require the use of a three-sided double snake frame directly below it (see page 55).

Ordering Guide for Enclosure Panels

Super Erecta and Super Adjustable Wire Shelving Units Super Erecta Solid Shelving Units

Ends — Panels required for each end according to shelf width, as follows:

Nominal Post Height (in.) (mm)	18" (457mm) Nominal Shelf Width	21" (530mm) Nominal Shelf Width	24" (610mm) Nominal Shelf Width	30" (760mm) Nominal Shelf Width	36" (914mm) Nominal Shelf Width
54 1370	(1) EP35	(1) EP35	(1) EP55	(2) EP35	(1) EP35 (1) EP55
63 1600	(1) EP36	(1) EP36	(1) EP56	(2) EP36	(1) EP36 (1) EP56
74 1880	(1) EP37	(1) EP37	(1) EP57	(2) EP37	(1) EP37 (1) EP57

Backs — Requires multiple panels in quantities shown for specific length shelf:

For Wire Shelves:

Nominal Post Height (in.) (mm)	30" (760mm) Nominal Shelf Length	36" (914mm) Nominal Shelf Length	42" (1066mm) Nominal Shelf Length	48" (1219mm) Nominal Shelf Length	54" (1370mm) Nominal Shelf Length	60" (1524mm) Nominal Shelf Length	72" (1825mm) Nominal Shelf Length
54 1370	(2) EP35	(1) EP35 (1) EP55	(2) EP55	(2) EP35 (1) EP55	(1) EP35 (2) EP55	(3) EP55	(1) EP35 (3) EP55
63 1600	(2) EP36	(1) EP36 (1) EP56	(2) EP56	(2) EP36 (1) EP56	(1) EP36 (2) EP56	(3) EP56	(1) EP36 (3) EP56
74 1880	(2) EP37	(1) EP37 (1) EP57	(2) EP57	(2) EP37 (1) EP57	(1) EP37 (2) EP57	(3) EP57	(1) EP37 (3) EP57

For Solid Shelves\*:

Nominal Post Height (in.) (mm)	30" (760mm) Nominal Shelf Length	36" (914mm) Nominal Shelf Length	42" (1066mm) Nominal Shelf Length	48" (1219mm) Nominal Shelf Length	54" (1370mm) Nominal Shelf Length	60" (1524mm) Nominal Shelf Length	72" (1825mm) Nominal Shelf Length
54 1370	(1) EP55	(2) EP35	(1) EP35 (1) EP55	(2) EP55	N/A	(1) EP35 (2) EP55	N/A (1) EP35 (2) EP55
63 1600	(1) EP56	(2) EP36	(1) EP36 (1) EP56	(2) EP56	N/A	(1) EP36 (2) EP56	N/A (1) EP36 (2) EP56
74 1880	(1) EP57	(2) EP37	(2) EP37 (1) EP57	(2) EP57	N/A	(1) EP37 (2) EP57	N/A (1) EP37 (2) EP57

\*Note: Units with a solid shelf in the top position require the use of a three-sided double snake frame directly below it (see page 57).



Super Adjustable Super Erecta Cart with Enclosure Panels

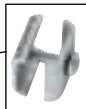

8 included per kit

Hardware Kit for Mobile Applications

It is recommended that additional clamp assemblies be used to secure the enclosure panels to the intermediate shelves on a mobile unit or transport cart. For the most abusive mobile applications, use two clamp assemblies at each intermediate shelf level for each enclosure panel.

Cat. No. **9970Z** Kit of 8 clamp assemblies

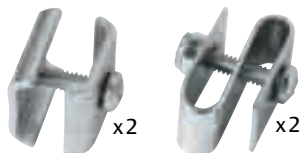

Mounting Kit for Enclosure Panel

Replacement Mounting Kit for Enclosure Panel

Kit includes two security S-hooks and two clamp assemblies.

Cat. No. **9970EPZ**

Shelf-to-Shelf Dividers — 9.25

Full height dividers efficiently compartmentalize the space between two shelves. Corrosion proof. Compatible with Super Erecta and Super Adjustable wire shelves.

Fits Shelf Depth (mm)		Nominal Height (in./mm)		Approx. Pkd. Wt. (lbs./kg)		Cat. No.
18, 21	457, 530	16	406	2.3	1.0	MD18-16
18, 21	457, 530	20	508	2.5	1.1	MD18-20
18, 21	457, 530	24	610	3.8	1.7	MD18-24
24	610	16	406	2.8	1.2	MD24-16
24	610	20	508	3.0	1.3	MD24-20
24	610	24	610	4.4	2.0	MD24-24

\*Note: -16 parts have three panels, -20 parts have four panels, -24 parts have five panels.

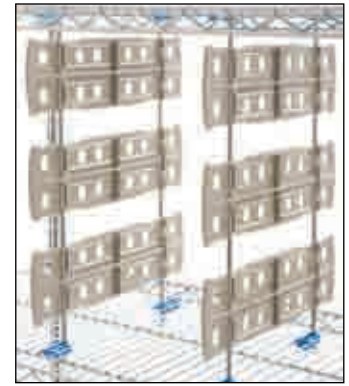

Shelf-to-Shelf Dividers

Rods and Tabs — 10.04

Form side and back enclosures for a shelving unit. Can also serve as uniform dividers within unit by passing through shelves from top to bottom. Recommended spacing: every 6" (150mm) to 12" (305mm), depending upon shelf contents.

Rods

Min. Post Height (in.)	Rod Length (mm)	Approx. Pkd. Wt. (lbs./kg)		Cat. No. Plated	Cat. No. Stainless
54	52 1320	1	0.5	R52C	R52S
63	61 1549	1	0.5	R61C	R61S
74	72 1830	1 1/4	0.6	R72C	R72S
86	84 2135	1 1/2	0.7	R84C	R84S

Tabs

Rods are shipped with 4 tabs per rod.

Additional Tabs — Bag of 12 Cat. No. 9084Z



Rod with Tab in place

Three-Sided Double Snake Frames — 10.04

Provide additional support or access to floor with these sturdy square snake frames. Plated finish.

Width/Length (in./mm)		Approx. Pkd. Wt. (lbs./kg)		Cat. No. Plated
18x24	457x610	5	2.3	SF31N3C
18x30	457x760	6	2.7	SF32N3C
18x36	457x914	6 1/2	2.7	SF33N3C
18x42	457x1066	7	3.2	SF34N3C
18x48	457x1219	7 3/4	3.5	SF35N3C
18x60	457x1524	8	3.6	SF36N3C
18x72	457x1829	9	4.1	SF37N3C
21x24	530x610	5	2.3	SF41N3C
21x30	530x760	6	2.7	SF42N3C
21x36	530x914	6 1/2	2.7	SF43N3C
21x42	530x1066	7	3.2	SF44N3C
21x48	530x1219	8	3.6	SF45N3C
21x60	530x1524	8 1/2	3.8	SF46N3C
21x72	530x1829	10	4.5	SF47N3C
24x24	610x610	6	2.7	SF51N3C
24x30	610x760	7	3.2	SF52N3C
24x36	610x914	7 1/2	3.4	SF53N3C
24x42	610x1066	8	3.6	SF54N3C
24x48	610x1219	9	4.1	SF55N3C
24x60	610x1524	10	4.5	SF56N3C
24x72	610x1829	11	5.0	SF57N3C



Three-sided Double Snake Frame

Hanger Rails — 10.05

Convenient rail fits on posts along the width or length of the unit. Optional hooks can hang from rail at any point.

Length† (in./mm)	Approx. Pkd. Wt. (lbs./kg)	Cat. No.		Cat. No.		Cat. No.	
		Chrome	Black	White	Smoked Glass	Designer Colors	
14	355	H114C	H114B	H114W	H114-DSG	H114-D	
18	457	H118C	H118B	H118W	H118-DSG	H118-D	
24	610	H124C	H124B	H124W	H124-DSG	H124-D	
30	760	H130C	H130B	H130W	H130-DSG	H130-D	
36	914	H136C	H136B	H136W	H136-DSG	H136-D	
48	1219	H148C	H148B	H148W	H148-DSG	H148-D	

†14", 18" and 24" (355, 457 and 610mm) sizes fit shelf width (depth). 30", 36" and 48" (760, 914 and 1219mm) sizes fit shelf length.

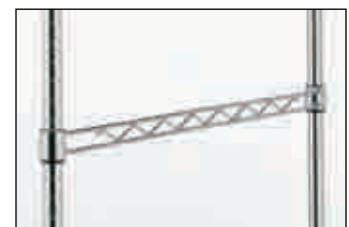

Hanger Rail

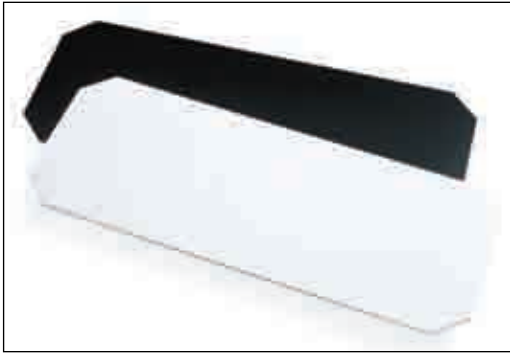

Decorator Shelf Inlays

Decorator Shelf Inlays — 10.06

Hardboard mats prevent small items from falling through wire shelves. Fit between posts and level with top of shelf edge. Reversible, black and white. Packed individually.

Width/Length (in.) (mm)		Cat. No.
14x36	355x914	1436BWI
14x48	355x1219	1448BWI
18x24	457x610	1824BWI
18x36	457x914	1836BWI
18x48	457x1219	1848BWI
24x24	610x610	2424BWI
24x36	610x914	2436BWI
24x48	610x1219	2448BWI



Clear Shelf Inlays

Clear Shelf Inlays — 10.06

Nearly invisible plastic mat retains open-wire look of shelves and allows light penetration. Sold in packages of 4.

Width/Length (in.) (mm)			Cat. No.	Width/Length (in.) (mm)			Cat. No.
14x36	355x914	1436CI-4		21x36	530x914	2136CI-4	
14x48	355x1219	1448CI-4		21x48	530x1219	2148CI-4	
14x60	355x1524	1460CI-4		21x60	530x1524	2160CI-4	
18x36	457x914	1836CI-4		24x36	610x914	2436CI-4	
18x48	457x1219	1848CI-4		24x48	610x1219	2448CI-4	
18x60	457x1524	1860CI-4		24x60	610x1524	2460CI-4	

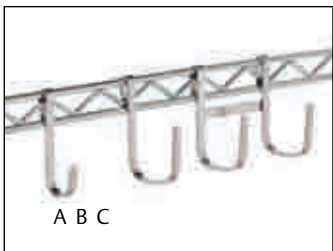

Snap-on Hooks

Snap-On Hooks — 10.05

Multi-purpose hooks in three styles attach to hanger rails, mounting rails or shelves for instant access.

Description	Height (in.) (mm)	Cat. No. Chrome	Cat. No. Black
Style A — Small	3 <sup>7</sup> / <sub>16</sub> 90	HK23C	HK23B
Style B — Large	3 <sup>7</sup> / <sub>16</sub> 90	HK25C	HK25B
Style C — Double	3 <sup>7</sup> / <sub>16</sub> 90	HK26C	

Garment Hanger Tube with Brackets — 10.05

Hanger tubes attach easily under Super Erecta shelves for hanging garments. Available in 18", 21" and 24" (457, 530 and 610mm) widths and in same length as shelves.



Garment Hanger Tube with Brackets

Tube Length (in.) (mm)		Approx. Pkd. Wt. (lbs.) (kg)		Shelf Width 18" (457mm)	Shelf Width 21" (530mm)	Shelf Width 24" (610mm)
24	610	2 <sup>1</sup> / <sub>2</sub>	1.1	AT2418NC	AT2421NC	AT2424NC
30	760	2 <sup>1</sup> / <sub>2</sub>	1.1	AT3018NC	AT3021NC	AT3024NC
36	914	3	1.4	AT3618NC	AT3621NC	AT3624NC
42	1066	3 <sup>1</sup> / <sub>2</sub>	1.6	AT4218NC	AT4221NC	AT4224NC
48	1219	3 <sup>1</sup> / <sub>2</sub>	1.6	AT4818NC	AT4821NC	AT4824NC
60	1524	4	1.8	AT6018NC	AT6021NC	AT6024NC
72	1828	4 <sup>1</sup> / <sub>2</sub>	2.0	AT7218NC	AT7221NC	AT7224NC

Tray Slides — 10.04

Free up shelves for more efficient use of space. Available in chrome and Metroseal 3 finish. 22<sup>3</sup>/<sub>4</sub>" H. (578mm).

Width		Overall Depth		Slide Profile		On Center Slide Spacing		Fits Shelf Width		Approx. Weight/Pair		Cat. No. Chrome	Cat. No. Metroseal 3 with Microban®
(in.)	(mm)	(in.)	(mm)	(in.)	(mm)	(in.)	(mm)	(in.)	(mm)	(lbs.)	(kg)		
14 <sup>5</sup> / <sub>8</sub>	371	2 <sup>1</sup> / <sub>4</sub>	56	1 <sup>1</sup> / <sub>2</sub>	37	1 <sup>1</sup> / <sub>2</sub>	37	18	457	9 <sup>1</sup> / <sub>2</sub>	4.3	15SNC	15SNK3
20	508	2 <sup>1</sup> / <sub>4</sub>	56	1 <sup>1</sup> / <sub>2</sub>	37	1 <sup>1</sup> / <sub>2</sub>	37	24	610	11	5.0	20SNC	20SNK3



Tray Slides

Super Erecta® Slide System — 10.04

A super space-saving solution. Using Super Erecta® wire units 21" or 24" (530 and 610mm) wide, tote boxes and this innovative slide system, you have the flexibility to create a custom configuration that can be positioned quickly on new or existing units without the use of tools. Finish is nickel-chrome wire with clear protective coating.

Outside Slide Dimensions Height/Width/Length		Fits Shelf Width		Adaptable Boxes		Approx. Pkd. Wt.		Cat. No.
(in.)	(mm)	(in.)	(mm)			(lbs.)	(kg)	
10 <sup>1</sup> / <sub>4</sub> x20 <sup>3</sup> / <sub>8</sub> x21 <sup>5</sup> / <sub>8</sub>	256x510x537	24	610	TB/MTB93030		4 <sup>3</sup> / <sub>4</sub>	2.1	SS2NC
				TB/MTB93060				
				TB/MTB93080				
10 <sup>1</sup> / <sub>4</sub> x14x17 <sup>1</sup> / <sub>8</sub>	256x355x430	21	530	TB/MTB92035		3 <sup>1</sup> / <sub>2</sub>	1.5	SS3NC
				TB/MTB92060				
				TB/MTB92080				
10 <sup>1</sup> / <sub>4</sub> x25 <sup>1</sup> / <sub>8</sub> x17 <sup>1</sup> / <sub>8</sub>	256x630x430	21	530	TB/MTB93030*		4	1.8	SS4NC
				TB/MTB93060*				
				TB/MTB93080*				

\*Fits SS4NC with box turned sideways.

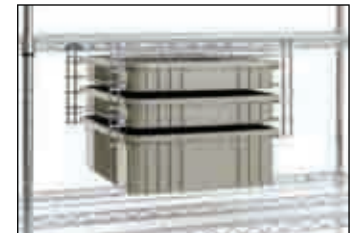

Super Erecta Slide System in place on shelf (Tote box sold separately)

Adjustable Undershelf Slides — 10.04

These slides can be spaced to fit any width container or tote box.

Item	Approx. Pkd. Wt.		Cat. No. (pair)
	(lbs.)	(kg)	
For 18" (457mm) wide shelf	1	0.4	US18NA
*For 21" (530mm) wide shelf	1	0.4	US21NA
For 24" (610mm) wide shelf	1	0.4	US24NA

\*Not adaptable to 24" (610mm) long shelf.



Adjustable Undershelf Slide

File Basket — 10.05

The convenient place to keep files and papers.

- Measures 2<sup>5</sup>/<sub>8</sub>" W. x 12<sup>3</sup>/<sub>4</sub>" L. x 8<sup>3</sup>/<sub>4</sub>" H. (67mm W. x 324mm L. x 222mm H.).
- Large enough to hold standard-size file folders.
- Attaches easily.

Width/Length		Height		Approx. Pkd. Wt.		Cat. No.
(in.)	(mm)	(in.)	(mm)	(lbs.)	(kg)	
2 <sup>5</sup> / <sub>8</sub> x12 <sup>3</sup> / <sub>4</sub>	63x330	8 <sup>3</sup> / <sub>4</sub>	228	2.1	1.0	PH1239C



File Basket



Indicates antimicrobial product.



Large Display/Storage Basket

**Storage Baskets — 10.05**

Generous-sized baskets attach in seconds to hanger rail or shelves.

	Width/Length/Depth		Approx. Pkd. Wt.		Cat. No. Plated	Cat. No. Black	Cat. No. White	Cat. No. Smoked Glass	Cat. No. Designer Colors
	(in.)	(mm)	(lbs.)	(kg)					
13 <sup>3</sup> / <sub>8</sub> x5x7	345	127x180	8 <sup>1</sup> / <sub>2</sub>	4	H209C	H209B	H209W	H209-DSG	H209-D
17 <sup>3</sup> / <sub>8</sub> x7 <sup>1</sup> / <sub>2</sub> x5	440	190x127	7	3	H210C	H210B	H210W	H210-DSG	H210-D
17 <sup>3</sup> / <sub>8</sub> x7 <sup>1</sup> / <sub>2</sub> x10	440	190x255	11	5	H212C	H212B	H212W	H212-DSG	H212-D

**Swing Hanger — 10.05**

Attaches to post to provide convenient storage for hanging items. Red epoxy finish.

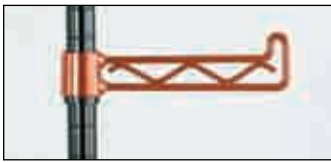

Swing Hanger

Arm Length	Weight Capacity		Cat. No.	
(in.)	(mm)	(lbs.)		(kg)
6 <sup>1</sup> / <sub>4</sub>	160	20	9	H110R

**Extension Display Hanger — 10.05**

Snaps on Super Erecta Shelf hanger rails and shelf frames. Accepts standard carded merchandise.



Extension Display Hanger

Length	Approx. Pkd. Wt.	Finish/Color*	Cat. No.
6	.25 .1	Chrome	HHK6C
6	.25 .1	Black	HHK6B
8	.25 .1	Chrome	HHK8C
8	.25 .1	Black	HHK8B

\*White, smoked glass and designer colors also available. Allow 4-6 week lead time.

**Color Shelf Marker — 10.05**

Color code for effective organization. Snaps securely to the front edge of Super Erecta and Super Adjustable Super Erecta Wire Shelving.

Shelf Marker Size				Shelf Marker Size			
(in.)	(mm)	Color	Cat. No.	(in.)	(mm)	Color	Cat. No.
6x1 1/4	152x32	Blue	<b>CSM6-B</b>	6x1 1/4	152x32	White	<b>CSM6-W</b>
6x1 1/4	152x32	Green	<b>CSM6-G</b>	6x1 1/4	152x32	Yellow	<b>CSM6-Y</b>
6x1 1/4	152x32	Red	<b>CSM6-R</b>	6x1 1/4	152x32	Gray	<b>CSM6-GR</b>
6x1 1/4	152x32	Tan	<b>CSM6-T</b>				



Color Shelf Markers



CSM6-B



CSM6-G



CSM6-R



CSM6-T



CSM6-W



CSM6-Y

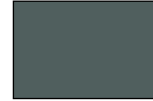

CSM6-GR

**Label Holders**

It's easy to identify shelf contents with these snap-on plastic holders, available in four styles and a variety of sizes. Labels not included.

**1 1/4" (32mm) Label Holders — 10.05**

Gray. Holds most commercial labels. Available in a variety of lengths.

Label Size		Fits Shelf Length		Cat. No.
(in.)	(mm)	(in.)	(mm)	
3x1 1/4	75x32	All		<b>9990P</b>
13x1 1/4	330x32	18	457	<b>9990P1</b>
19x1 1/4	480x32	24	610	<b>9990P2</b>
25x1 1/4	635x32	30	760	<b>9990P30</b>
31x1 1/4	725x32	36	914	<b>9990P3</b>
43x1 1/4	1090x32	48	1219	<b>9990P4</b>
55x1 1/4	1395x32	60	1520	<b>9990P5</b>

For Cantilever Shelves, use 3" (75mm) label holder only.



1 1/4" (32mm) Label Holder

**Clear Label Holders — 10.05**

Clear plastic allows decorator colors to show through. Holds most commercial 1 1/4" (32mm) labels.

Label Size		Fits Shelf Length		Cat. No.
(in.)	(mm)	(in.)	(mm)	
3x1 1/4	75x32	All		<b>9990CL</b>
13x1 1/4	330x32	18	457	<b>9990CL1</b>
19x1 1/4	480x32	24	610	<b>9990CL2</b>
25x1 1/4	635x32	30	760	<b>9990CL30</b>
31x1 1/4	725x32	36	914	<b>9990CL3</b>
43x1 1/4	1090x32	48	1219	<b>9990CL4</b>
55x1 1/4	1395x32	60	1520	<b>9990CL5</b>

For Cantilever Shelves, use 3" (75mm) label holder only.



Clear Label Holder

**Slanted Label Holders — 10.05**

Gray solid plastic holder puts 1 1/4" (32mm) labels on slant for easier viewing.

Label Size		Fits Shelf Length		Cat. No.
(in.)	(mm)	(in.)	(mm)	
3x1 1/4	75x32	All		<b>9990SL</b>
13x1 1/4	330x32	18	457	<b>9990SL1</b>
19x1 1/4	480x32	24	610	<b>9990SL2</b>
25x1 1/4	635x32	30	760	<b>9990SL30</b>
31x1 1/4	725x32	36	914	<b>9990SL3</b>
43x1 1/4	1090x32	48	1219	<b>9990SL4</b>
55x1 1/4	1395x32	60	1520	<b>9990SL5</b>

For Cantilever Shelves, use 3" (75mm) label holder only.



Slanted Label Holder

**Metro Bins — 10.08**

Convenient way to organize and identify small items.

- Hopper-front design allows for easy access and clear visibility
- Lightweight, durable polypropylene and polyethylene bins have molded front slots to accept labels.
- For application specific totes refer to index.

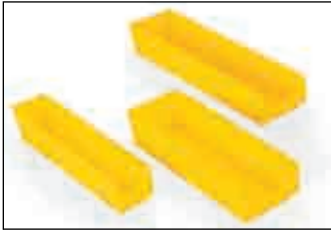

Shelf Bins — Nesting

**Shelf Bins — Nesting**

These bins are sized to work on the two most popular shelf widths 18" (457mm) and 24" (610mm) for efficient handling and exchange.



Supply Bins — Stacking

Outside Dimensions Width/Length/Height (in.)	Outside Dimensions Width/Length/Height (mm)	Approx. Pkd. 23 Wt./Ctn. (kg)		Bin Carton Quantity	Color	Bin Cat. No.	Divider Cat. No.	Divider Carton Quantity
		(lbs.)	(kg)					
11 <sup>5</sup> / <sub>8</sub> x4 <sup>1</sup> / <sub>8</sub> x4	295x105x102	9	4.1	24	Yellow	<b>MB30120Y</b>	<b>MB40120</b>	24
11 <sup>5</sup> / <sub>8</sub> x6 <sup>1</sup> / <sub>8</sub> x4	295x168x102	7	3.2	12	Yellow	<b>MB30130Y</b>	<b>MB40130</b>	24
17 <sup>7</sup> / <sub>8</sub> x4 <sup>1</sup> / <sub>8</sub> x4	454x105x102	7	3.2	12	Yellow	<b>MB30128Y</b>	<b>MB40120</b>	24
17 <sup>7</sup> / <sub>8</sub> x6 <sup>5</sup> / <sub>8</sub> x4	454x168x102	9	4.1	12	Yellow	<b>MB30138Y</b>	<b>MB40130</b>	24
17 <sup>7</sup> / <sub>8</sub> x11 <sup>1</sup> / <sub>8</sub> x4	454x283x102	15	6.8	12	Yellow	<b>MB30178Y</b>	<b>MB40170</b>	24
23 <sup>5</sup> / <sub>8</sub> x4 <sup>1</sup> / <sub>8</sub> x4	600x105x102	11	4.9	12	Yellow	<b>MB30124Y</b>	<b>MB40120</b>	24
23 <sup>5</sup> / <sub>8</sub> x6 <sup>5</sup> / <sub>8</sub> x4	600x168x102	8	3.6	6	Yellow	<b>MB30164Y</b>	<b>MB40130</b>	24
23 <sup>5</sup> / <sub>8</sub> x11 <sup>1</sup> / <sub>8</sub> x4	600x283x102	11	4.9	6	Yellow	<b>MB30174Y</b>	<b>MB40170</b>	24

**Note:** Bins are available in carton quantities only. Bins above are priced per each but must be ordered in multiples of carton quantity. (For example: MB30138Y is available in quantities of 12, 24, 36. List price refers to the price of 1 bin.)  
Dividers are available in carton quantities only. Dividers are sold by the carton and priced by the carton. (For example: 1 MB40120 = 24 dividers, the list price is for 24 dividers).



MB30265B

**Supply Bins — Stacking**

Stackable design maximizes vertical storage efficiency. Reinforced design adds strength and prevents spreading.



MB30283B

Outside Dimensions Width/Length/Height (in.)	Outside Dimensions Width/Length/Height (mm)	Approx. Pkd. Wt./Ctn. (kg)		Bin Carton Quantity	Color	Bin Cat. No.	Divider Cat. No.	Divider Carton Quantity
		(lbs.)	(kg)					
10 <sup>7</sup> / <sub>8</sub> x5 <sup>1</sup> / <sub>2</sub> x5	276x140x127	10	4.5	12	Blue	<b>MB30230B</b>	<b>MB40230</b>	6
10 <sup>7</sup> / <sub>8</sub> x11x5	276x279x127	10	4.5	6	Blue	<b>MB30235B</b>	<b>MB40230</b>	6
14 <sup>3</sup> / <sub>4</sub> x5 <sup>1</sup> / <sub>2</sub> x5	375x140x127	13	5.9	12	Blue	<b>MB30234B</b>	N/A	
14 <sup>3</sup> / <sub>4</sub> x8 <sup>1</sup> / <sub>4</sub> x7	375x210x178	24	10.9	12	Blue	<b>MB30240B</b>	<b>MB40245</b>	6
14 <sup>3</sup> / <sub>4</sub> x16 <sup>1</sup> / <sub>2</sub> x7	375x419x178	21	9.5	6	Blue	<b>MB30250B</b>	<b>MB40245</b>	6
18x8 <sup>1</sup> / <sub>4</sub> x9	457x210x229	17	7.7	6	Blue	<b>MB30265B*</b>	<b>MB40265</b>	6
20x12 <sup>3</sup> / <sub>8</sub> x6	508x314x203	9	4.1	3	Blue	<b>MB30281B*</b>	N/A	
20x18 <sup>3</sup> / <sub>8</sub> x12	508x467x305	7	3.2	1	Blue	<b>MB30283B*</b>	N/A	
8x20 <sup>1</sup> / <sub>2</sub> x7	205x521x178	21	9.5	6	Tan	<b>MB30348T†</b>		

\*MB30265B, MB30281B, MB30283B are not designed for use with hanging rail system.

†Includes two dividers.

**Note:** MB30234B, MB30281B, MB30283B — no dividers available.

Bins feature a full-width hanger lip that is designed for use with hanging systems.

Bins are available in carton quantities only. Bins above are priced per each but must be ordered in multiples of carton quantity. (For example: MB30235B is available in quantities of 6, 12, 18. List price refers to the price of 1 bin.)

Dividers are available in carton quantities only. Dividers are sold by the carton and priced by the carton. (For example: 1 MB40230 = 6 dividers, the list price is for 6 dividers).



MB34240G

**Bulk Supply Tub — Nesting**

Ruggedly constructed, perfect for storing large bulky items.

Outside Dimensions Width/Length/Height (in.)	Outside Dimensions Width/Length/Height (mm)	Approx. Pkd. Wt./Ctn. (kg)		Carton Quantity	Bin Color	Cat. No.
		(lbs.)	(kg)			
24 <sup>1</sup> / <sub>2</sub> x19x9 <sup>1</sup> / <sub>2</sub>	622x483x241	20	9.1	6	Gray	<b>MB34240G</b>

**Note:** Bins are available in carton quantities only. Bins above are priced per each but must be ordered in multiples of carton quantity. (For example: MB34240G is available in quantities of 6, 12, 18 etc. List price refers to the price of 1 bin.)

## Shelving and Cart Covers — 11.80

### Opaque Solid Fabric Covers

Protect contents from dust and other airborne contaminants.

- Deter pilferage: Allow units to be loaded prior to transport.
- Available in:
  - Uncoated White (100% knitted polyester)
  - Coated White (waterproof vinyl-nylon)
  - Uncoated Mariner Blue (200 denier nylon)
  - Coated Mariner Blue (waterproof vinyl-nylon)
- Choice of Velcro® or zipper closures.

Catalog numbers shown are for white cover. Add “MB” suffix to order Mariner Blue (i.e. 21X48X54UCMB)



21X48X54UCMB  
(shown in Mariner Blue)

Length/Height (in.) (mm)		White Nylon Uncoated		White Vinyl Coated	
		Zippered Closure Cat. No.	Velcro Closure Cat. No.	Zippered Closure Cat. No.	Velcro Closure Cat. No.
<b>FOR SHELF TRUCKS &amp; CARTS 18" (457mm) DEEP</b>					
36x54	914x1370	18X36X54UC	18X36X54VUC	18X36X54C	18X36X54VC
36x62	914x1550	18X36X62UC	18X36X62VUC	18X36X62C	18X36X62VC
48x54	1219x1370	18X48X54UC	18X48X54VUC	18X48X54C	18X48X54VC
48x62	1219x1550	18X48X62UC	18X48X62VUC	18X48X62C	18X48X62VC
60x54	1524x1370	18X60X54UC	18X60X54VUC	18X60X54C	18X60X54VC
60x62	1524x1550	18X60X62UC	18X60X62VUC	18X60X62C	18X60X62VC
<b>FOR SHELF TRUCKS &amp; CARTS 21" (530mm) DEEP</b>					
48x54	1219x1370	21X48X54UC	21X48X54VUC	21X48X54C	21X48X54VC
48x62	1219x1550	21X48X62UC	21X48X62VUC	21X48X62C	21X48X62VC
48x74	1219x1850	21X48X74UC	21X48X74VUC	21X48X74C	21X48X74VC
60x54	1524x1370	21X60X54UC	21X60X54VUC	21X60X54C	21X60X54VC
60x62	1524x1550	21X60X62UC	21X60X62VUC	21X60X62C	21X60X62VC
60x74	1524x1850	21X60X74UC	21X60X74VUC	21X60X74C	21X60X74VC
<b>FOR SHELF TRUCKS &amp; CARTS 24" (610mm) DEEP</b>					
36x54	914x1370	24X36X54UC	24X36X54VUC	24X36X54C	24X36X54VC
36x62	914x1550	24X36X62UC	24X36X62VUC	24X36X62C	24X36X62VC
36x74	914x1850	24X36X74UC	24X36X74VUC	24X36X74C	24X36X74VC
48x54	1219x1370	24X48X54UC	24X48X54VUC	24X48X54C	24X48X54VC
48x62	1219x1550	24X48X62UC	24X48X62VUC	24X48X62C	24X48X62VC
48x74	1219x1850	24X48X74UC	24X48X74VUC	24X48X74C	24X48X74VC
60x54	1524x1370	24X60X54UC	24X60X54VUC	24X60X54C	24X60X54VC
60x62	1524x1550	24X60X62UC	24X60X62VUC	24X60X62C	24X60X62VC
60x74	1524x1850	24X60X74UC	24X60X74VUC	24X60X74C	24X60X74VC
72x54	1825x1370	24X72X54UC	24X72X54VUC	24X72X54C	24X72X54VC
72x62	1825x1550	24X72X62UC	24X72X62VUC	24X72X62C	24X72X62VC
72x74	1825x1850	24X72X74UC	24X72X74VUC	24X72X74C	24X72X74VC

\*Cart covers are non-returnable.

Note: 86" (2185mm) high covers, in 24" (610mm) depth, available by special order.

### Clear Vinyl Cart Covers

- Allows visual access while protecting shelf contents from dust and other airborne contaminants.
- Vinyl construction with Velcro closures.
- Available for 18x36" (457x914mm) shelving.

Length/Height (in.) (mm)		Cat. No.
36x32	914x889	GWCVC41
36x52	914x1320	GWCVC62



Clear Vinyl  
Cart Cover

✓ Indicates antimicrobial product.



Keyboard Tray

**Keyboard Tray — 10.06**

Attaches to all Metro wire shelves, 36" (914mm) length or longer. Mouse Tray adapts to left or right of Keyboard Tray. Flip-top compartment provides convenient storage. Constructed of durable high-impact polystyrene. Assembles easily.

- Hardware included for attachment to Metro wire shelves; template provided for attachment to solid desk surfaces.
  - Keyboard Tray Dimensions: 22" L. (559mm) x 15 1/2" W. (394mm).
  - Dimension with Mouse Tray fully extended: 29 1/2" L. (749mm) x 15 1/2" W. (394mm).
- Cat. No. **CKS1522BL**



Wire Management Clip

**Wire Management Clip — 10.06**

Keeps wires and cables neatly organized both horizontally and vertically. Easily snaps over the edge of any Super Erecta wire or qwikSLOT shelf. Black epoxy finish.

Width		Length		Approx. Pkd. Wt.		Cat. No.
(in.)	(mm)	(in.)	(mm)	(lbs.)	(kg)	
2	51	2	51	.5	.25	<b>CWM</b>



Power Strip

**Power Strip — 10.06**

- Mounts quickly and easily to either a Super Erecta or qwikSLOT post.
- Includes a 15 foot (4572mm) long cord.
- Mounting brackets and hardware included.
- UL/CSA approved.
- 15 Amp Circuit Breaker.
- Illuminated Power Switch. 15A/125VAC.60Hz/1875 W.
- Gray/blue finish.
- 14/3 SJT Molded Power Supply Cord.

Width		Length		Approx. Pkd. Wt.		Cat. No.
(in.)	(mm)	(in.)	(mm)	(lbs.)	(kg)	
1 1/2	38	48	1219	6	2.72	<b>CPS48</b>

**Surface Mount Swing Arm for Flat Monitor — 10.06**

Cat. No. **LTFMA**

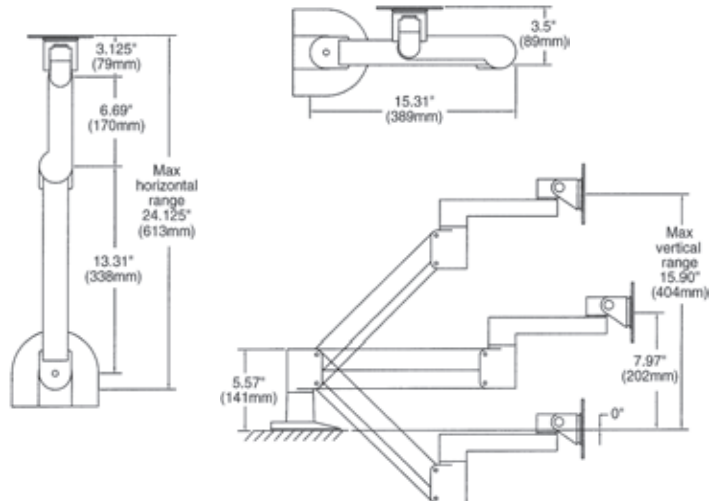



*Call today!*

**1.800.992.1776**

*A customer service representative is standing by to assist you.*



Not in the USA? Look on the back cover of your catalog for the contact information you need.

“Thank you for calling Metro, how can we help you?”

## Super Erecta® Solid Shelving

Setting the standard for solid shelving.

Perfect for applications involving spillage. Provides barrier between floor and bottom shelf contents to deter contamination.

- Shelf design features a 1/8" (3.2mm) raised "ship's edge" on all four sides to contain spills.
- Louvered/embossed shelf allows air circulation.
- Available in several styles and materials for a variety of applications. Shelves are constructed with 18-gauge stainless steel (Type 304) or galvanized materials.
- **Galvanized shelves** with uncoated cast corners are ideal for applications requiring a solid shelving or work surface and minimum resistance to corrosion. Available in flat solid and louvered/embossed styles.
- **Standard Stainless Steel solid shelves** (Type 304) with epoxy-coated cast corners address the majority of applications for solid, corrosion resistant shelves or work surfaces. Available in flat solid and louvered/embossed styles.
- **Premium Autoclave/Cart Washable Stainless Steel solid shelves** (Type 304) feature an all-stainless construction to withstand high temperature, corrosive applications. Available in flat solid style.



Flat Solid Stainless Shelves with black powder-coated corners



SiteSelect™ Posts are grooved at 1" (25mm) increments and numbered at 2" (50mm) increments. Posts are double-grooved every 8" (203mm) for easy identification.

### Metro Tip:

Use Metro Flat Solid Shelving at the bottom of a storage unit to maintain cleanliness by providing a barrier between floor and shelf contents above.

### SiteSelect Posts for Super Erecta® Solid Shelving — 10.20

Stationary posts are fitted with adjustable leveling bolts to compensate for uneven surfaces. Mobile posts come without leveling bolt to accommodate stem casters. Special length posts are available.†

Height*		Approx. Pkd. Wt.		Cat. No. Chrome Stationary	Cat. No. Chrome Mobile	Cat. No. Stainless Stationary**	Cat. No. Stainless Mobile
(in.)	(mm)	(lbs.)	(kg)				
7 1/2	191	1/2	0.3	<b>7P</b>	<b>7UP</b>		
14 1/2	370	1	0.5	<b>13P</b>	<b>13UP</b>	<b>13PS</b>	<b>13UPS</b>
27 1/2	699	1 3/4	0.75	<b>27P</b>	<b>27UP</b>	<b>27PS</b>	<b>27UPS</b>
34 1/2	875	2	0.9	<b>33P</b>	<b>33UP</b>	<b>33PS</b>	<b>33UPS</b>
54 9/16	1385	3	1.4	<b>54P</b>	<b>54UP</b>	<b>54PS</b>	<b>54UPS</b>
62 9/16	1590	3 1/2	1.6	<b>63P</b>	<b>63UP</b>	<b>63PS</b>	<b>63UPS</b>
74 5/8	1895	4	1.8	<b>74P</b>	<b>74UP</b>	<b>74PS</b>	<b>74UPS</b>
86 5/8	2200	5	2.3	<b>86P</b>	<b>86UP</b>	<b>86PS</b>	<b>86UPS</b>
96 5/8	2454	5 1/2	2.5	<b>***96P</b>			

†Note: Special length posts are available, priced at next higher length plus a cutting charge. Post lengths to be specified as cut to a round number, ie: 74P cut to 69" (1753mm) . . . This will result in an overall post height with adjustment of 69 3/8" (1762mm) to 69 7/8" (1775mm). \*Height includes leveling bolt and cap.

\*\*Stainless stationary post includes stainless leveling bolt. \*\*\*96P should not be used on units less than 24" (610mm) deep. Consult Metro Engineering for alternate recommendations.

## Super Erecta® Solid Shelving — 10.20

Shelves are priced and sold individually. For standard packaging, the number of shelves per box varies by size. 14"/18" (355/457mm) wide solid shelving: less than 60" (1524mm) long (no more than 4 per carton); 60" (1524mm) long (no more than 2 per carton); 21" (530mm) wide solid shelving: less than 42" (1066mm) long (no more than 4 per carton); 42" (1066mm) or longer (no more than 2 per carton); 24" (610mm) wide solid shelving: 24", 30" (610, 760mm) long (no more than 4 per carton); 36" (914mm) or longer (no more than 2 per carton).

Width/Length (in.) (mm)	Approx. Pkd. Wt. per Shelf (lbs.) (kg)	GALVANIZED		STANDARD STAINLESS STEEL		
		Cat. No. Flat	Cat. No. Louvered/Embossed	Cat. No. Flat	Cat. No. Louvered/Embossed	
14x24	355x610	10 4.5	1424FG	1424LG	1424FS	1424LS
14x30	355x760	12 5.4	1430FG	1430LG	1430FS	1430LS
14x36	355x914	14 6.4	1436FG	1436LG	1436FS	1436LS
14x42	355x1066	15 6.8	1442FG	1442LG	1442FS	1442LS
14x48	355x1219	17 7.7	1448FG	1448LG	1448FS	1448LS
14x60	355x1524	22 9.9	1460FG	1460LG	1460FS	1460LS
18x24	457x610	11 5.0	1824FG	1824LG	1824FS	1824LS
18x30	457x760	14 6.4	1830FG	1830LG	1830FS	1830LS
18x36	457x914	16 7.3	1836FG	1836LG	1836FS	1836LS
18x42	457x1066	18 8.2	1842FG	1842LG	1842FS	1842LS
18x48	457x1219	20 9.1	1848FG	1848LG	1848FS	1848LS
18x60	457x1524	24 10.9	1860FG	1860LG	1860FS	1860LS
21x24	530x610	13 5.9	2124FG	2124LG	2124FS	2124LS
21x30	530x760	15 6.8	2130FG	2130LG	2130FS	2130LS
21x36	530x914	18 8.2	2136FG	2136LG	2136FS	2136LS
21x42	530x1066	21 9.5	2142FG	2142LG	2142FS	2142LS
21x48	530x1219	23 10.4	2148FG	2148LG	2148FS	2148LS
21x60	530x1524	26 11.8	2160FG	2160LG	2160FS	2160LS
24x24	610x610	15 6.8	2424FG	2424LG	2424FS	2424LS
24x30	610x760	17 7.7	2430FG	2430LG	2430FS	2430LS
24x36	610x914	19 8.6	2436FG	2436LG	2436FS	2436LS
24x42	610x1066	21 9.5	2442FG	2442LG	2442FS	2442LS
24x48	610x1219	24 10.9	2448FG	2448LG	2448FS	2448LS
24x60	610x1524	31 14.0	2460FG	2460LG	2460FS	2460LS

Note: For 24"x72" (610x1829mm) size, contact your Metro representative.  
Weight Capacity (evenly distributed load): Shelves 48" (1219mm) or less in length can hold up to 800 lbs. (363kg). 60" (1524mm) long shelves can hold up to 600 lbs. (272kg).

## Autoclavable/Cart-Washable Solid Stainless Shelving

All-stainless construction will address autoclave and cart washing applications.

Width/Length (in.) (mm)	Approx. Pkd. Wt. per Shelf (lbs.) (kg)	Cat. No. Autoclavable Stainless	GALVANIZED		STANDARD STAINLESS STEEL	
			Cat. No. Flat	Cat. No. Louvered/Embossed	Cat. No. Flat	Cat. No. Louvered/Embossed
14x24	355x610	10 4.5	1424NFS			
14x30	355x760	12 5.4	1430NFS			
14x36	355x914	14 6.4	1436NFS			
14x42	355x1066	15 6.8	1442NFS			
14x48	355x1219	17 7.7	1448NFS			
14x60	355x1524	22 9.9	1460NFS			
18x24	457x610	11 5.0	1824NFS			
18x30	457x760	14 6.4	1830NFS			
18x36	457x914	16 7.3	1836NFS			
18x42	457x1066	18 8.2	1842NFS			
18x48	457x1219	20 9.1	1848NFS			
18x60	457x1524	24 10.9	1860NFS			
21x24	530x610	13 5.9	2124NFS			
21x30	530x760	15 6.8	2130NFS			
21x36	530x914	18 8.2	2136NFS			
21x42	530x1066	21 9.5	2142NFS			
21x48	530x1219	23 10.4	2148NFS			
21x60	530x1524	26 11.8	2160NFS			
24x24	610x610	15 6.8	2424NFS			
24x30	610x760	17 7.7	2430NFS			
24x36	610x914	19 8.6	2436NFS			
24x42	610x1066	21 9.5	2442NFS			
24x48	610x1219	24 10.9	2448NFS			
24x60	610x1524	31 14.0	2460NFS			

### Metro Tip:

Order aluminum split sleeves with stainless C-rings for corrosive, high-temperature autoclave or cart washing applications. (Cat. No. 9986S, one bag required per shelf).

## Super Erecta® Counter Units — 10.35

To create a counter unit, select the following components:

- 2 each — 14" (355mm) deep upper shelves, listed above
- 2 each — 24" (610mm) deep lower shelves, listed above
- 2 each — upper front posts, listed below
- 2 each — lower front posts, listed below
- 2 each — 63" (1600mm) or 74" (1880mm) high back posts (page 66).

## Special Posts For Counter Units — 10.35

	Unit Height (in.) (mm)	Post Height* (in.) (mm)	Approx. Pkd. Wt. (lbs.) (kg)	Cat. No. Plated	Cat. No. Stainless
Upper Front Posts	63 1600	28 <sup>5</sup> / <sub>8</sub> 727	1 <sup>1</sup> / <sub>2</sub> 0.7	27PF	27PFS
	74 1880	40 <sup>5</sup> / <sub>8</sub> 1032	2 0.9	39PF	39PFS
Lower Front Posts	All Heights	34 <sup>1</sup> / <sub>2</sub> 877	2 0.9	33PM	33PMS

\*Height includes leveling bolt and cap.



Counter Unit with galvanized shelves.

Shelf Ledges for Solid Shelves — 10.25

Sturdy 4" (101mm) ledges contain items on shelves. Spring-clip tabs included for attachment.



4" (101mm) Ledges

Fits Shelf Length		Approx. Pkd. Wt. Per 6 Pieces		Cat. No. Plated	Cat. No. Stainless
(in.)	(mm)	(lbs.)	(kg)		
14	355	7½	3.4	L14WC	L14WS
18	457	9	4.1	L18WC	L18WS
21	530	10½	4.7	L21WC	L21WS
24	610	12	5.4	L24WC	L24WS
30	760	13½	6.0	L30WC	L30WS
36	914	16½	7.4	L36WC	L36WS
42	1066	19½	8.7	L42WC	L42WS
48	1219	22½	10.1	L48WC	L48WS
60	1524	30	13.5	L60WC	L60WS

\*Actual ledge length is approximately 1" (25mm) shorter than nominal shelf length/width.

Rods and Tabs for Solid Shelves — 10.25

Create a more versatile system by enclosing sides and back of an entire unit. Tabs required to attach rods to a 4-shelf unit are supplied. Additional tabs also available in bags of 6.

Additional Tabs  
Bag of 6  
Cat. No. 9184Z



Rods with Tab in place

Rods

Min. Post Height	Rod Length		Approx. Pkd. Wt.		Cat. No. Plated
	(in.)	(mm)	(lbs.)	(kg)	
54	52	1320	1	0.5	R52FC
63	60	1524	1	0.5	R60FC
74	72	1830	1¼	0.6	R72FC
86	84	2135	1½	0.7	R84FC

Shelf Dividers — 10.25

The easy way to keep shelves orderly. Eight inch (203mm) high dividers attach with spring clips (provided).



Shelf Dividers

Length		Approx. Pkd. Wt. Per 6 Pieces		Cat. No. Plated	Cat. No. Stainless
(in.)	(mm)	(lbs.)	(kg)		
14	355	12	5.4	DD14FC	
18	457	13½	6.0	DD18FC	DD18FS
21	530	15	6.8	DD21FC	
24	610	16½	7.4	DD24FC	DD24FS

Solid Shelf Joining Clamp — 10.25

Save time and money by eliminating adjacent posts and replacing with solid shelf joining clamps. Join units end-to-end, back-to-back or at right angles. Two clamps required per shelf to attach to adjacent units.

Zinc. Cat. No. 9998Z



Joining Clamp

**Note:** Shelves with joining clamps can only be attached to shelves supported by two or more posts.

Adjustable Undershelf Slides — 10.25

Create a convenient drawer system by combining a tote box with these slides. Two slides are required, and can be spaced to fit any width container.



Adjustable Undershelf Slides

Item	Approx. Pkd. Wt.		Cat. No. Solid
	(lbs.)	(kg)	
For 18" (457mm) wide shelf	1	0.4	US18FA
For 21" (530mm) wide shelf	1	0.4	US21FA
For 24" (610mm) wide shelf	1	0.4	US24FA

\*For application-specific totes, refer to index.

## Erecta Shelf® Shelving

This easy-to-assemble system puts space to work practically anywhere.

- Units go together without tools — shelf grooves simply lock into uprights at 5" (127mm) increments.
- Accessories create a truly versatile system.

### Erecta Shelf® Uprights — 10.50

Width/Length		Approx. Pkd. Wt.		Cat. No. Chrome
(in.)	(mm)	(lbs.)	(kg)	
12x53½	305x1359	7	3.2	1252C
12x63½	305x1613	8	3.3	1262C
12x73½	305x1867	9	4.1	1272C
12x88½	305x2248	11	5.0	1287C
18x53½	457x1359	8	3.3	1852C
18x63½	457x1613	9	4.1	1862C
18x73½	457x1867	11	5.0	1872C
18x88½	457x2248	13½	6.2	1887C

Packaging: 6 uprights to a carton.

### Erecta Shelf® Wire Shelves — 10.50

Width/Length		Approx. Pkd. Wt.		Cat. No. Chrome
(in.)	(mm)	(lbs.)	(kg)	
12x24	305x610	5	2.2	1224C
12x30	305x760	6	2.7	1230C
12x36	305x914	7	3.1	1236C
12x42	305x1066	8¼	3.7	1242C
12x48	305x1219	9½	4.2	1248C
12x60	305x1524	12	5.4	1260C
18x24	457x610	6½	2.9	1824C
18x30	457x760	8	3.6	1830C
18x36	457x914	10	4.5	1836C
18x42	457x1066	11	4.9	1842C
18x48	457x1219	12½	5.6	1848C
18x60	457x1524	16	7.2	1860C



### Shelf Dividers — 10.56

Keep shelves orderly with these snap-in-place, 8" (203mm) high dividers.

Shelf Width		Approx. Pkd. Wt. Per 6 Pieces		Cat. No. Plated
(in.)	(mm)	(lbs.)	(kg)	
12	305	12	5.4	DD12C
18	457	13½	6.1	DD18C
24	610	16½	7.4	DD24C



Shelf Divider

### Corner Braces

Join units at right angles and eliminate the need for one upright with the use of two corner braces per shelf.

Cat. No. 9999Z



Corner Brace



HD Super Solid Stainless Shelving with black powder-coated corners



HD Super Post



HD Super Stem Caster Post



HD Super Stem Caster

Stainless solid shelving has black powder-coated corners. Galvanized solid shelving has uncoated cast corners.

HD Super™ shelves, posts, and casters are not compatible with Super Erecta or Super Adjustable Super Erecta components.

### HD Super™ Solid Shelving

Heavy-duty system features 16-gauge solid shelves.

- Large 1<sup>5</sup>/<sub>8</sub>" (41mm) diameter posts and 2" (51mm) shelf adjustability.
- Shelf options include flat or louvered/embossed styles, and galvanized or stainless steel finishes.

#### HD Super Flat Shelves — 10.65

Width/Length (in.) (mm)		Approx. Pkd. Wt. (lbs.) (kg)		Cat. No. Galvanized	Cat. No. Stainless
18x36	457x914	21	9.5	1836HFG	1836HFS
18x42	457x1066	23	10.4	1842HFG	1842HFS
18x48	457x1219	26	11.7	1848HFG	1848HFS
18x54	457x1370	28	12.7	1854HFG	1854HFS
18x60	457x1524	31	14.0	1860HFG	1860HFS
24x36	610x914	25	11.3	2436HFG	2436HFS
24x42	610x1066	29	13.1	2442HFG	2442HFS
24x48	610x1219	32	14.4	2448HFG	2448HFS
24x54	610x1370	35	15.8	2454HFG	2454HFS
24x60	610x1524	38	17.1	2460HFG	2460HFS

#### HD Super Louvered/Embossed Shelves — 10.65

Width/Length (in.) (mm)		Approx. Pkd. Wt. (lbs.) (kg)		Cat. No. Stainless
18x36	457x914	21	9.5	1836HLS
18x42	457x1066	23	10.4	1842HLS
18x48	457x1219	26	11.7	1848HLS
18x54	457x1370	28	12.7	1854HLS
18x60	457x1524	31	14.0	1860HLS
24x36	610x914	25	11.3	2436HLS
24x42	610x1066	29	13.1	2442HLS
24x48	610x1219	32	14.4	2448HLS
24x54	610x1370	35	15.8	2454HLS
24x60	610x1524	38	17.1	2460HLS

**Note:** The weight capacity of a HD Super Shelf is 1,000 lbs. (457kg) per shelf, evenly distributed across shelf.

#### HD Super Stationary Posts — 10.65

Height* (in.) (mm)	Approx. Pkd. Wt. (lbs.) (kg)	Cat. No. Chrome	Cat. No. Stainless
56 1421	5.8 2.6	54HPC	54HPS
64 1624	6.3 2.9	63HPC	63HPS
76 1929	7.5 3.4	74HPC	74HPS

\*Height includes leveling foot and cap.

**Note:** Special length posts are available. For more information, contact your Metro representative.

**Packaging:** 4 posts to a carton.

#### HD Super Stem Caster Posts — 10.65

Height (in.) (mm)	Approx. Pkd. Wt. (lbs.) (kg)	Cat. No. Chrome	Cat. No. Stainless
54 <sup>9</sup> / <sub>16</sub> 1386	5.7 2.5	54UHPC	54UHPS
62 <sup>9</sup> / <sub>16</sub> 1590	6.3 2.8	63UHPC	63UHPS
74 <sup>5</sup> / <sub>8</sub> 1894	7.5 3.3	74UHPC	74UHPS

#### HD Super Stem Casters — 10.65

Includes donut bumpers with each caster.

Wheel Diameter (in.) (mm)	Face Diameter (in.) (mm)	Type	Wheel Tread	Approx. Pkd. Wt. (lbs.) (kg)	Cat. No.
5 127	1 <sup>1</sup> / <sub>2</sub> 38.1	Swivel	Polyurethane	3 <sup>1</sup> / <sub>2</sub> 1.5	5HHP
5 127	1 <sup>1</sup> / <sub>2</sub> 38.1	Brake	Polyurethane	3 <sup>3</sup> / <sub>4</sub> 1.5	5HHPB

Load rating per caster: 400 lbs. (182kg).

## HD Super™ Dunnage Shelves — 10.67

Static load capacity (uniformly distributed)

- 48" (1219mm) shelf: 3,000 lbs. (1361kg).
- 60" (1524mm) shelf: 2,400 lbs. (1089kg).
- For use on H.D. 1<sup>5</sup>/<sub>8</sub>" (41mm) posts only.
- Removable wire deck.

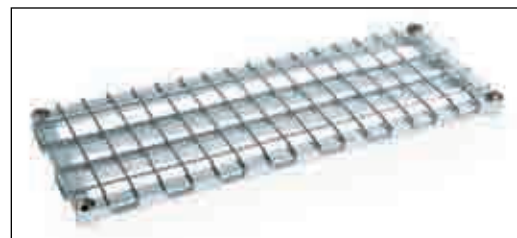

HD Super Dunnage Shelf

Width/Length (in.) (mm)		Approx. Pkd. Wt. (lbs.) (kg)		Cat. No. Chrome	Cat. No. Metroseal 3 with Microban®	Cat. No. Stainless
18x48	457x1219	35	15.7	<b>1848HDC</b>	<b>1848HDRK3</b>	<b>1848HDRS</b>
18x60	457x1524	43	19.3	<b>1860HDC</b>	<b>1860HDRK3</b>	<b>1860HDRS</b>
24x48	610x1219	38	17.1	<b>2448HDC</b>	<b>2448HDRK3</b>	<b>2448HDRS</b>
24x60	610x1524	47	21.1	<b>2460HDC</b>	<b>2460HDRK3</b>	<b>2460HDRS</b>

**Important:** In stationary shelving, stability decreases as the ratio of height to width increases and when heavier loads are placed on upper shelves. Keep units as wide and low as possible, using the dunnage shelf as the bottom shelf. If two dunnage shelves are being used, both should be placed within the lower half of the unit.

**Note:** Not compatible with Super Erecta or Super Adjustable Super Erecta components.



HD Super™ Cantilever Shelf

## HD Super™ Cantilever Shelf — 10.67

Width/Length (in.) (mm)		Approx. Pkd. Wt. (lbs.) (kg)		Cat. No. Chrome	Cat. No. Stainless
12x54	304x1372	11.8	5.3	<b>1254CHC</b>	<b>1254CHS</b>
12x60	304x1524	12.7	5.7	<b>1260CHC</b>	<b>1260CHS</b>

## HD Super™ Replacement Parts — 10.65

Replacement HD Super™ Aluminum Split Sleeves with Zinc Ring  
4 pair per bag  
Cat. No. **9986HZ**



Replacement HD Super™ Aluminum Split Sleeve

## Replacement 5<sup>1</sup>/<sub>2</sub>" (140mm) Donut Bumpers

Cat. No. **9992H**

Above fit 1<sup>5</sup>/<sub>8</sub>" (41mm) posts only.



Replacement 5<sup>1</sup>/<sub>2</sub>" (140mm) Donut Bumper

## Replacement HD Super™ Plastic Split Sleeves

4 pair per bag  
Plastic — Cat. No. **9985H**



Replacement HD Super™ Plastic Split Sleeve

## 3<sup>1</sup>/<sub>2</sub>" (89mm) Foot Plates

Cat. No. **9993HS**



3<sup>1</sup>/<sub>2</sub>" (89mm) Foot Plate

Post Clamps  
Cat. No. **9994HZ**



Post Clamp

## Wall Mounting Brackets

(not shown)  
Cat. No. **9984HZ**



Indicates antimicrobial product.



# WALL SHELVING & CARTS

Wall Shelving & Storage Systems .....74-82  
Premium Polymer Utility Carts ..... 83  
Polymer Utility Carts .....84-86  
Utility Carts.....87-88  
Heavy-Duty Utility Carts .....89

# Wall-to-wall efficiency.

SmartWall G3™ Productivity System  
Organized, efficient wall space at work.



A unique storage and work station system for often underutilized wall space.

**Wall-mounted tracks** are the foundation for attaching . . .

- Productivity stations with grids, accessories, and storage shelves
- Wall Shelving using uprights and Metro shelves
- Customizable storage space using combinations of shelving, grids, and specialized accessories

SmartWall G3 will keep these areas cleaner and more organized.

- Prep areas
- Janitorial supply
- Above carts that are in a staging area or a storage room
- Above sinks, work tables, casework, equipment, or bulk floor storage



**Flexible, Robust Design:** Wall tracks and uprights are designed to interface with wood studs, plywood, concrete, and other suitable wall structures.

**Easy to Adapt:** Uprights and grid brackets can be easily repositioned along the track before being fastened to the wall. Shelves and accessories are easy to add and remove.

**Easy to Install:** Once the tracks are installed level, shelving and task stations can be quickly configured.

**Easy to Clean:** Shelves, shelf supports, and grids can easily be removed for thorough cleaning of walls. Wall tracks and uprights can easily be wiped clean.

**Durable Finishes:** Super Erecta Brite for dry environments; Metroseal 3 epoxy for wet or damp environments with built-in Microban® antimicrobial product protection to inhibit the growth of bacteria, mold, mildew, and fungus that cause odors and product degradation.



**General Guidelines**

**Selecting Wall Tracks.**

Wall track or combination of tracks must be at least 2" (51mm) longer than the desired span of shelves. 1" (25mm) on each end of the span of tracks is reserved for hardware that acts as a stop. *(Example: If 152" (3860mm) of wall track could be mounted, then the length of a shelf tier cannot exceed 150" (3810mm).*

**Uprights.**

- 15" (381mm) uprights: 1 shelf tier maximum
- 30" (762mm) uprights: 3 shelf tiers maximum
- 45" (1143mm) uprights: 4 shelf tiers maximum

**Shelves.**

When configuring side-by-side shelving units, the adjacent shelves on the same tier must have the same depth. Minimum space between shelf tiers is 9" (229mm).

**Note:** When using MetroMax i shelves with SmartWall G3 shelf supports, order one adapter kit per shelf (Cat. No. M9997-4).

**Shelf Supports.**

Order to match up with the depth of the shelf.

**Configuring Basic Wall Shelving**

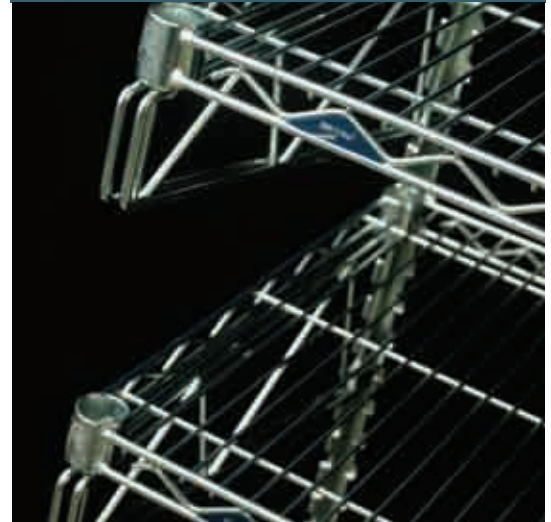

**Ordering Guide**

**Single Shelving Unit**

1. Select a wall track or tracks.
2. Select two uprights.
3. Select from Super Erecta wire or solid shelves, Super Erecta Pro, MetroMax Q, or MetroMax i shelves.
4. Select single shelf supports (2 per shelf)

**To order the unit pictured:**

Qty.	Cat. No.	
1	SW40BR	Wall Track
2	SWU45BR	Upright
1	2436BR	Wire Shelf
2	SWS24BR	Single Shelf Support
2	1836BR	Wire Shelf
4	SWS18BR	Single Shelf Support



**Side-by-Side Shelving Unit**

**To order the unit pictured:**

Qty.	Cat. No.	
1	SW56K3	Wall Track
1	SW40K3	Wall Track
4	SWU30K3	Upright
6	1830NK3	Wire Shelf
4	SWS18K3	Single Shelf Support
4	SWD18K3	Double Shelf Support



Single shelf supports are used on the ends of the wall shelf unit. Double (or Intermediate) shelf supports are used to join adjacent units.



**S**  
Single Shelf Support



**D**  
Double (Intermediate) Shelf Support

## Configuring Basic Task Stations



### General Guidelines

#### Selecting Wall Tracks

Wall track or combination of tracks must be at least 2" (51mm) longer than the desired span of shelves. 1" (25mm) on each end of the span of tracks is reserved for hardware that acts as a stop. (Example: If 152" (3860mm) of wall track could be mounted, then the length of a shelf tier cannot exceed 150" (3810mm).

#### Grids

Grids may attach directly to the uprights. Grids may not overhang the uprights by more than 6" (152mm). When uprights are not used, select the appropriate grid bracket kit based on the configuration.

#### Uprights and Shelf Supports

Enable standard Super Erecta, Super Erecta Pro, MetroMax Q, and MetroMax i shelves to be used as part of the task station.

#### Combinations of Grids and Shelves

Grids can be mounted directly behind shelves, but shelf supports and grids cannot occupy the same slots on the upright. Once the grid has been mounted to the upright, the shelf support can be mounted to its own slots and can be adjusted on 3" (76mm) increments within the grid space.

## Ordering Guide

### Medium-Duty Task Station

1. Select wall track or tracks.
2. Select uprights. (two per task station)
3. Select shelves and single shelf supports. (two supports per shelf)
4. Select grid and accessories.

#### Notes:

- Most often shelves and grids of the same length are used together.
- Maximum unit capacity when mounted to wood studs or plywood is 400 lbs. (180kg).

**Note:** Refer to catalog sheet 10.42 for weight capacities in other types of wall construction.

### Standard-Duty Task Station

1. Select wall track or tracks.
2. Select grid or multiple grids.
3. Select SWGB1 grid bracket kit. (one per grid)
4. Select accessories including bulk grid shelves (pictured).

#### Notes:

- Maximum unit capacity when mounted to wood studs or plywood is 250 lbs. (113kg).

**Note:** Refer to catalog sheet 10.42 for weight capacities in other types of wall construction.

- Grids may be mounted to the wall without wall tracks using SWGB2 or WGBRKT grid bracket kits.



#### Consists of:

Qty.	Cat. No.	
1	SW40K3	Wall Track
2	SWU30K3	Upright
1	1836NK3	Wire Shelf
2	SWS18K3	Single Shelf Support
1	WG1836K3	Wire Grid
1	SWA1	Accessory Pack



#### Consists of:

Qty.	Cat. No.	
1	SW40K3	Wall Track
1	WG3036K3	Wire Grid
1	SWGB1	Grid Bracket Kit
1	GS1836K3	Grid Shelf
1	SWA2	Accessory Pack

Medium-Duty Task Station — 10.42b

Cat. No. SWK36-1

- Bulk overhead storage space with a 1836NK3 wire shelf
- 18" x 36" (457 x 914mm) grid space
- 40" (1016mm) track
- Overall dimensions: Length x Height  
40" x 31 1/4" (1016 x 793mm)

Consists of:

Qty.	Cat. No.	
1	SW40K3	Wall Track
2	SWU30K3	Upright
2	SWS18K3	Single Shelf Support
1	1836NK3	Shelf
1	WG1836K3	Wire Grid



Standard-Duty Task Station — 10.42b

Cat. No. SWK36-2

- Standard duty 50 lb. capacity overhead shelf
- 40" (1016mm) track and 30" x 36" (762 x 914mm) grid space
- Overall dimensions: Length x Height  
40" x 39 11/16" (1016 x 1008mm)

Consists of:

Qty.	Cat. No.	
1	SW40K3	Wall Track
1	SWG B1	Grid Bracket Kit
1	WG3036K3	Grid
1	GS1836K3	Grid Shelf



Accessory Pack — Sink — 10.42b

Cat. No. SWA1

- Packaged in one carton
- To fit minimum 18" x 36" (457 x 914mm) grid space
- Grids not included

Consists of:

Qty.	Cat. No.	
1	H210K3	Wire Basket
1	IWA-11K3	Lid Holder
1	FCH	Utensil Cylinder
1	FC1	Cylinder Holder
2	PGHK6K3	Prong Hook
6	HK23C	Standard Hook

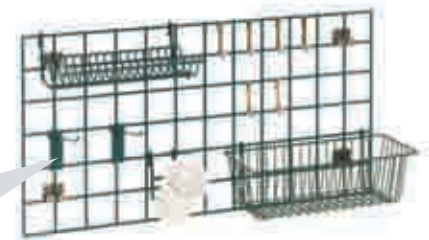

Wire Grid and Grid Brackets Not Included.

Accessory Pack — Prep — 10.42b

Cat. No. SWA2

- Packaged in one carton
- To fit minimum 18" x 36" (457 x 914mm) grid space
- Grids not included

Consists of:

Qty.	Cat. No.	
1	PBA-GSDK3	Small Shelf
2	H210K3	Wire Basket
1	DD3722A	Bin Holder
1	MB30230B	Small Bin
2	PGHK6K3	Prong Hook
6	HK23C	Standard Hook



Wire Grid and Grid Brackets Not Included.

SmartWall G3 can be configured in endless combinations of storage shelves, task station grids, and space management accessories. Visit [metro.com/SWG3](http://metro.com/SWG3) for more ideas on how to put wall space to work.

SmartWall G3 Components — 10.42



Wall Track



**Wall Tracks** (minimum one per system)

- Joiner plates and stop fastener hardware included. Does not include hardware to mount wall tracks to the wall.
- Replacement joiner plate (1) and stop fastener hardware (2 sets): Cat. No. RPTRK-HDWE

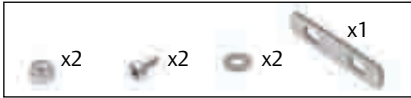

Hardware

Actual Length (in.)	Actual Length (mm)	Actual Depth (in.)	Actual Depth (mm)	Actual Width (in.)	Actual Width (mm)	Approx. Pkd. Wt. (lbs.)	Approx. Pkd. Wt. (kg)	Cat. No. Super Erecta Brite	Cat. No. Metroseal 3
40	1016	3/4	19	1 9/16	40	5.0	2.2	SW40BR	SW40K3
56	1423	3/4	19	1 9/16	40	6.0	2.6	SW56BR	SW56K3
72	1829	3/4	19	1 9/16	40	7.0	3.1	SW72BR	SW72K3

\*Note: Tracks can be cut to length, but Metro does not provide this service. Touch-up paint for Metroseal 3 tracks is available. Cat. No. TP-K2.

**Uprights** (For medium-duty applications, minimum two per system. Sold by the piece)

- Built-in slots allow shelf supports and grids to attach without tools or hardware.
- 1 1/2" (38mm) slot spacing allows shelves and grids to be adjusted on 1 1/2" (38mm) increments

Actual Length (in.)	Actual Length (mm)	Actual Width (in.)	Actual Width (mm)	Actual Depth (in.)	Actual Depth (mm)	Number of Slots	Approx. Pkd. Wt. (lbs.)	Approx. Pkd. Wt. (kg)	Cat. No. Super Erecta Brite	Cat. No. Metroseal 3
16	406	1 1/8	29	1 7/8	48	7	1.8	0.8	SWU15BR	SWU15K3
31	787	1 1/8	29	1 7/8	48	17	3.5	1.5	SWU30BR	SWU30K3
44 1/2	1130	1 1/8	29	1 7/8	48	26	5.3	2.3	SWU45BR	SWU45K3

**Shelf Supports** (Sold by the piece)

- Mount directly to slotted uprights. Suitable for use with Super Erecta, MetroMax Q, and MetroMax i shelves.
- Single shelf supports are used on each end of a single unit or side-by-side unit.
- Double (intermediate) shelf supports are used when configuring side-by-side wall shelving units.

**Single Shelf Supports**

Fits shelf depth	Actual Length (in.)	Actual Length (mm)	Actual Width (in.)	Actual Width (mm)	Actual Height (in.)	Actual Height (mm)	Approx. Pkd. Wt. (lbs.)	Approx. Pkd. Wt. (kg)	Cat. No. Super Erecta Brite	Cat. No. Metroseal 3
14" (355mm)	16 9/16	421	1 1/2	38	8 3/16	208	2.5	1.1	SWS14BR	SWS14K3
18" (457mm)	20 9/16	522	1 1/2	38	8 3/16	208	3.0	1.3	SWS18BR	SWS18K3
21" (530mm)	23 9/16	598	1 1/2	38	8 3/16	208	3.5	1.5	SWS21BR	SWS21K3
24" (610mm)	26 9/16	675	1 1/2	38	8 3/16	208	3.5	1.5	SWS24BR	SWS24K3

\*Note: Replacement plastic sleeve for shelf support. Cat. No. RP-SPSLV.

Note: When using MetroMax i shelves with shelf supports, please order 1 adapter kit per shelf. Cat. No. M9997-4

**Double (Intermediate) Shelf Supports**

Fits shelf depth	Actual Length (in.)	Actual Length (mm)	Actual Width (in.)	Actual Width (mm)	Actual Height (in.)	Actual Height (mm)	Approx. Pkd. Wt. (lbs.)	Approx. Pkd. Wt. (kg)	Cat. No. Super Erecta Brite	Cat. No. Metroseal 3
14" (355mm)	16 9/16	421	1 1/2	38	8 3/16	208	2.5	1.1	SWD14BR	SWD14K3
18" (457mm)	20 9/16	522	1 1/2	38	8 3/16	208	3.0	1.3	SWD18BR	SWD18K3
21" (530mm)	23 9/16	598	1 1/2	38	8 3/16	208	3.5	1.5	SWD21BR	SWD21K3
24" (610mm)	26 9/16	675	1 1/2	38	8 3/16	208	3.5	1.5	SWD24BR	SWD24K3

\*Note: Replacement plastic sleeve for shelf support. Cat. No. RP-SPSLV.

Note: When using MetroMax i shelves with shelf supports, please order 1 adapter kit per shelf. Cat. No. M9997-4

**Grid Mounting Brackets** (for standard-duty applications without uprights)

- Use to connect the grid to the wall when uprights are not used. One kit required per grid.

Description	Approx. Pkd. Wt. (lbs.)	Approx. Pkd. Wt. (kg)	Cat. No.
Bracket kit to connect grid to wall track; includes (2) top and (4) bottom (stainless steel)	2.0	0.9	SWGB1
Direct wall mount bracket kit; consists of (6) bottom brackets (stainless steel)	2.0	0.9	SWGB2
Direct wall mount bracket kit; consists of (6) black plastic brackets	2.0	0.9	WGBRKT

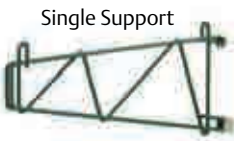

Single Support

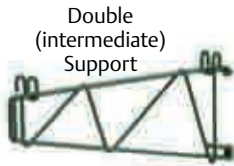

Double (intermediate) Support

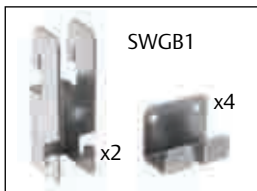

SWGB1

x4



SWGB2

WGBRKT

x6

x6

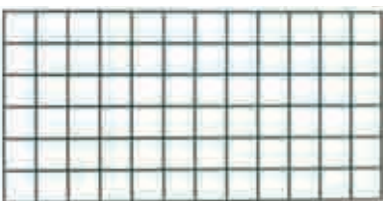

Grid: 18" x 36" (457 x 914mm)

**Wire Grids**

- Brackets to mount the grid to the wall track or the wall are not included and can attach directly to uprights without brackets or tools.
- Grid openings measure approximately 3" x 3" (76 x 76mm)

Width x Length (in.)	Width x Length (mm)	Approx. Pkd. Wt. (lbs.)	Approx. Pkd. Wt. (kg)	Cat. No. Plated	Cat. No. Metroseal 3
18x30	457x760	7.5	3.3	—	WG1830K3
18x36	457x914	9.0	4.1	WG1836BR	WG1836K3
18x48	457x1219	12.0	5.4	WG1848BR	WG1848K3
18x60	457x1524	14.0	6.4	WG1860BR	WG1860K3
24x36	610x914	12.0	5.4	—	WG2436K3
24x48	610x1219	15.5	7.0	—	WG2448K3
30x36	760x914	12.8	5.8	—	WG3036K3
30x48	760x1219	16.5	7.5	—	WG3048K3
33x54	838x1370	21.0	9.5	PBA-GPC	—

\*Note: Can be retrofitted to original MetroMax and MetroMax Q shelving.

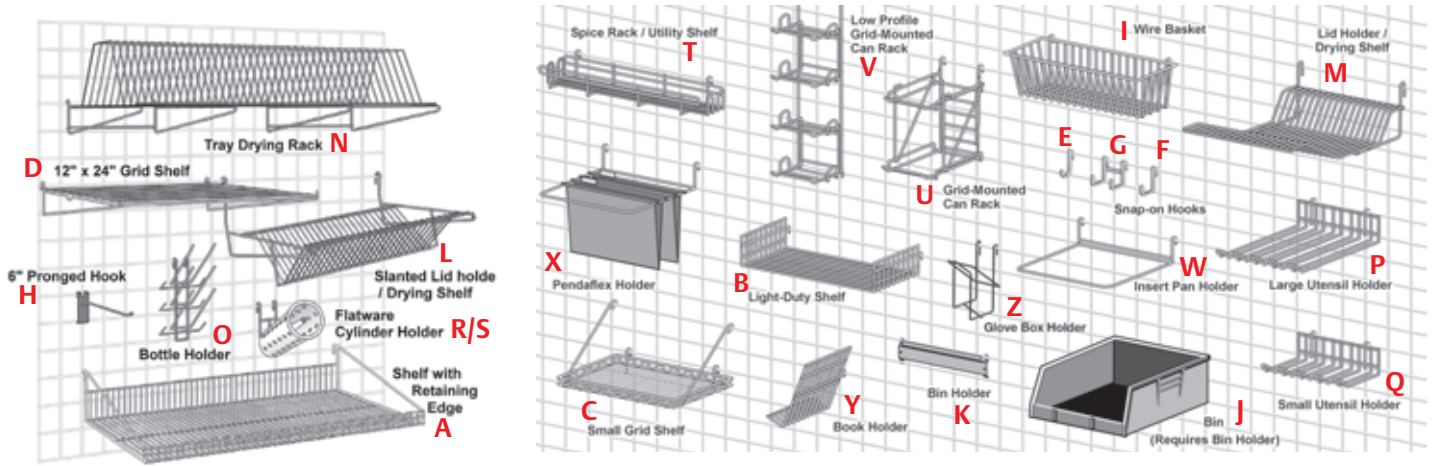

## Accessories for Grids — 10.43

### Shelves for Grids

		Width/Length/Height (in.)	(mm)	Approx. Pkd. Wt. (lbs.)	(kg)	Cat. No. Plated	Cat. No. Metroseal 3
A	14"x36" (356x914mm) Shelf w/Retaining Edge	15 <sup>9</sup> / <sub>16</sub> x35 <sup>1</sup> / <sub>4</sub> x7 <sup>3</sup> / <sub>4</sub>	391x895x197	12	4.5	—	GS1436K3
A	14"x48" (356x1219mm) Shelf w/Retaining Edge	15 <sup>9</sup> / <sub>16</sub> x47 <sup>1</sup> / <sub>4</sub> x7 <sup>3</sup> / <sub>4</sub>	391x1200x197	16	6.0	—	GS1448K3
A	18"x30" (457x762mm) Shelf w/Retaining Edge	19 <sup>9</sup> / <sub>16</sub> x29 <sup>1</sup> / <sub>4</sub> x7 <sup>3</sup> / <sub>4</sub>	492x743x197	15	5.6	—	GS1830K3
A	18"x36" (457x914mm) Shelf w/Retaining Edge	19 <sup>9</sup> / <sub>16</sub> x35 <sup>1</sup> / <sub>4</sub> x7 <sup>3</sup> / <sub>4</sub>	492x895x197	18	6.7	—	GS1836K3
A	18"x48" (457x1219mm) Shelf w/Retaining Edge	19 <sup>9</sup> / <sub>16</sub> x47 <sup>1</sup> / <sub>4</sub> x7 <sup>3</sup> / <sub>4</sub>	492x1200x197	24	9.0	—	GS1848K3
B	Light-Duty Shelf with Side Ledges	9 W.x18 <sup>1</sup> / <sub>2</sub> L.	228 W.x470 L.	4	1.8	PBA-GSD	PBA-GSDK3
C	Small Grid Shelf — 18" (457mm)	16 <sup>3</sup> / <sub>4</sub> W.x16 <sup>3</sup> / <sub>4</sub> L.	425 W.x425 L.	6	2.7	PBA-MS	PBA-MSK3
D	Flat Grid Shelf — 24" (610mm)	12 <sup>1</sup> / <sub>16</sub> x24x4	322x610x102	7	2.6	—	FGS1224K3

### Hooks

		Width/Length/Height (in.)	(mm)	Approx. Pkd. Wt. (lbs.)	(kg)	Cat. No. Chrome	Cat. No. Metroseal
E	Small Hook	1 <sup>1</sup> / <sub>4</sub> x3 <sup>1</sup> / <sub>2</sub>	32x89	—	—	HK23C	—
F	Large Hook	2x3 <sup>1</sup> / <sub>2</sub>	50x89	—	—	HK25C	—
G	Double Large Hook	2x3 <sup>1</sup> / <sub>2</sub>	50x89	—	—	HK26C	—
H	6" (152mm) Pronged Hook	1 <sup>1</sup> / <sub>4</sub> x7 <sup>5</sup> / <sub>16</sub> x5 <sup>5</sup> / <sub>8</sub>	32x194x92	.3	0.1	—	PGHK6K3

### Baskets

		Width/Length/Height (in.)	(mm)	Approx. Pkd. Wt. (lbs.)	(kg)	Cat. No. Chrome	Cat. No. Metroseal 3
I	Small Basket	13 <sup>3</sup> / <sub>8</sub> x5x7	345x127x180	8.5	4	H209C	H209K3
I	5" (127mm) Deep Large Basket	17 <sup>3</sup> / <sub>8</sub> x7 <sup>1</sup> / <sub>2</sub> x5	440x190x127	7	3	H210C	H210K3
I	10" (254mm) Deep Large Basket	17 <sup>3</sup> / <sub>8</sub> x7 <sup>1</sup> / <sub>2</sub> x10	440x190x255	11	5	H212C	H212K3

### Bins and Holders

		Width/Length/Height (in.)	(mm)	Approx. Pkd. Wt. (lbs.)	(kg)	Cat. No.
J	Blue Bin Packed 12/Ctn.	10 <sup>7</sup> / <sub>16</sub> x5 <sup>1</sup> / <sub>2</sub> x5	279x140x127	1	0.45	MB30230B
J	Blue Bin Packed 6/Ctn.	10 <sup>7</sup> / <sub>16</sub> x11x5	279x280x127	1.5	0.68	MB30235B
J	Blue Bin Packed 12/Ctn.	14 <sup>3</sup> / <sub>4</sub> x8 <sup>1</sup> / <sub>4</sub> x7	375x210x180	2	0.91	MB30240B
K	Single Bin Holder	3x <sup>1</sup> / <sub>2</sub> (LxH)	76x13 (LxH)	0.5	0.23	DD3722A
K	Small Bin Holder	11x3 (LxH)	280x76 (LxH)	1	.45	PBA-1BH
K	Large Bin Holder	22x3	559x76 (LxH)	2	.91	PBA-2BH

### Drying Rack Accessories

		Width/Length/Height (in.)	(mm)	Pkd. Wt. (lbs.)	(kg)	Cat. No. Plated	Cat. No. Metroseal 3
L	Slanted Lid Holder/Drying Shelf	14 <sup>1</sup> / <sub>8</sub> x20 <sup>3</sup> / <sub>16</sub> x12 <sup>1</sup> / <sub>8</sub>	359x527x307	5.0	2.3	—	IWA-S11K3
M	Lid Holder/Drying Shelf	8 <sup>1</sup> / <sub>4</sub> x13 <sup>1</sup> / <sub>2</sub> x4 <sup>1</sup> / <sub>2</sub>	210x343x114	2	0.9	—	IWA-11K3
N	Tray Drying Rack	14 <sup>9</sup> / <sub>16</sub> x46 <sup>1</sup> / <sub>4</sub> x10 <sup>3</sup> / <sub>16</sub>	371x1175x259	12.0	5.4	—	TDR48K3
O	6-Prong Bottle Holder	14 <sup>7</sup> / <sub>8</sub> x5 <sup>1</sup> / <sub>8</sub> x11	378x130x279	2.3	0.8	—	BH6K3

### Utensil Holders

		Width/Length/Height (in.)	(mm)	Approx. Pkd. Wt. (lbs.)	(kg)	Cat. No. Plated	Cat. No. Metroseal 3
P	Large Utensil Holder	10 <sup>1</sup> / <sub>2</sub> x10 <sup>3</sup> / <sub>8</sub> x4	267x264x102	4	1.8	—	IWA-12K3
Q	Small Utensil Holder	4 <sup>3</sup> / <sub>8</sub> x10 <sup>3</sup> / <sub>8</sub> x4	111x264x102	4	1.8	—	IWA-14K3
R	Flatware/Instrument Cylinder	4 <sup>5</sup> / <sub>16</sub> x4 <sup>5</sup> / <sub>16</sub> x5 <sup>1</sup> / <sub>2</sub>	109x109x140	0.3	0.1	—	FC1
S	Cylinder Holder	2 <sup>5</sup> / <sub>8</sub> x5 <sup>7</sup> / <sub>8</sub> x5 <sup>3</sup> / <sub>4</sub>	67x149x146	1.0	0.5	—	FCH

### Miscellaneous Accessories

		Width/Length/Height (in.)	(mm)	Approx. Pkd. Wt. (lbs.)	(kg)	Cat. No. Plated	Cat. No. Metroseal 3
T	Spice Rack/Utility Shelf	5 <sup>1</sup> / <sub>4</sub> x22 <sup>1</sup> / <sub>2</sub> x4	133x571x102	3.5	1.6	SR24BR	SR24K3
U	Grid Mounted Can Rack, 4 Capacity	8 <sup>1</sup> / <sub>4</sub> x13 <sup>3</sup> / <sub>4</sub> x12	210x349x305	4	1.8	CR4BR	—
V	Low-Profile Grid-Mounted Can Rack	6 <sup>1</sup> / <sub>2</sub> x7 <sup>3</sup> / <sub>4</sub> x28 <sup>1</sup> / <sub>2</sub>	165x197x724	4.3	2.0	CR4LPBR	—
W	Insert Pan Holder	7 <sup>1</sup> / <sub>2</sub> x12 <sup>1</sup> / <sub>2</sub> x4	190x317x102	2.3	1.0	STP3BR	—
X	Hanging File Holder	6 <sup>1</sup> / <sub>4</sub> W.x12 <sup>1</sup> / <sub>2</sub> L.	159 W.x317 L.	3	1.4	PBA-PFH	—
Y	Book Holder	2 W. x 9 H.	50 W.x228 H.	3	1.4	PBA-CHD	—
Z	Glove Box Holder (Vertical)	6 <sup>3</sup> / <sub>8</sub> W.x10 <sup>1</sup> / <sub>2</sub> H.	162 W.x267H.	2	0.9	—	GBHVK3

Inside Dimensions 5<sup>7</sup>/<sub>8</sub>" W.x3<sup>7</sup>/<sub>16</sub>" D. [267mm W.x87mm D.]



**Erecta Shelf® Wall Mounts — 10.56**

Used to create wall-mounted shelving units with 12" (305mm) or 18" (457mm) Erecta shelves of any length.

- Models are available to accommodate from one to five shelves. (Each mount consists of two shelf supports and mounting brackets.)
- Wall bolts or screws not included; they must be selected according to type of wall.
- Order shelves from page 69.



Wall Mounts with Shelf  
(Shelf sold separately, see page 39)

Width (in.)	Width (mm)	Height (in.)	Height (mm)	Capacity	Approx. Pkd. Wt. (Pr.)		Cat. No. Chrome
					(lbs.)	(kg)	
12	305	10 <sup>3</sup> / <sub>4</sub>	273	1 Shelf	2 <sup>1</sup> / <sub>2</sub>	1.1	<b>12WB1C</b>
12	305	20 <sup>13</sup> / <sub>16</sub>	528	1 to 3 Shelves	5	2.3	<b>12WB3C</b>
12	305	30 <sup>13</sup> / <sub>16</sub>	782	1 to 5 Shelves	7 <sup>1</sup> / <sub>4</sub>	3.2	<b>12WB5C</b>
18	457	11 <sup>3</sup> / <sub>4</sub>	298	1 Shelf	3	1.4	<b>18WB1C</b>
18	457	21 <sup>5</sup> / <sub>8</sub>	548	1 to 3 Shelves	6	2.7	<b>18WB3C</b>
18	457	31 <sup>5</sup> / <sub>8</sub>	807	1 to 5 Shelves	8 <sup>1</sup> / <sub>2</sub>	3.8	<b>18WB5C</b>

For additional mounting brackets (single) order Cat. No. **9975C**

Double mounting brackets are also available for use where continuous wall shelving is to be installed. Cat. No. **9976C**

Load Rating: 200 lbs. (91kg) per shelf, not to exceed 200 lbs. (91kg) per unit.

Units must be secured to sufficient wall support structure.



12WS12C  
Erecta Shelf® Wall Kit

**Erecta Shelf® Wall Kit — 10.56**

Kit includes two shelves, shelf supports, and mounting brackets. Wall bolts and screws not included; they must be selected according to type of wall. Chrome.

Shelf Length (in.)	Shelf Length (mm)	Overall Length (in.)	Overall Length (mm)	Shelf Width (in.)	Shelf Width (mm)	Overall Width (in.)	Overall Width (mm)	Overall Height (in.)	Overall Height (mm)	Approx. Pkd. Wt. (lbs.)	Approx. Pkd. Wt. (kg)	Cat. No.
24	610	26 <sup>1</sup> / <sub>4</sub>	673	12	305	13	330	21	530	18 <sup>1</sup> / <sub>2</sub>	8.3	<b>12WS12C</b>
36	914	38 <sup>1</sup> / <sub>4</sub>	971	12	305	13	330	21	530	25 <sup>1</sup> / <sub>4</sub>	11.3	<b>12WS32C</b>
48	1219	50 <sup>1</sup> / <sub>4</sub>	1283	12	305	13	330	21	530	32	14.4	<b>12WS52C</b>

Kit packaged in one box and UPS shippable.

Load Rating: 200 lbs. (91kg) per shelf, not to exceed 200 lbs. (91kg) per unit.

Units must be secured to sufficient wall support structure.

**Direct Wall Mount Shelving — 9.20**

Use standard Super Erecta stainless steel direct wall mount shelf supports with MetroMax shelves or open frames with wire drop in baskets. Order one MetroMax corner adapter kit with each shelf or shelf frame. Shelf supports are sold individually.

Single — Use at shelf ends; two are required for a stand-alone shelf.

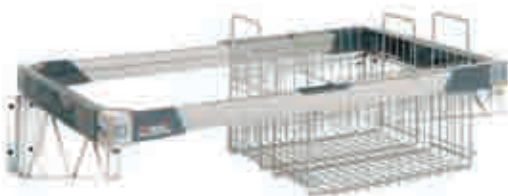

Wall Mount Brackets shown with MetroMax i Open Frame and Drop-In Basket.

Shelf Width (in.)	Shelf Width (mm)	Approx. Pkd. Wt.		Cat. No. Stainless Steel
		(lbs.)	(kg)	
18	457	2	0.9	<b>1WD18S</b>
24	610	2 <sup>1</sup> / <sub>4</sub>	1.0	<b>1WD24S</b>

Double — When constructing a run of shelves, use double shelf supports to join adjacent shelves.

Shelf Width (in.)	Shelf Width (mm)	Approx. Pkd. Wt.		Cat. No. Stainless Steel
		(lbs.)	(kg)	
18	457	3	1.4	<b>2WD18S</b>
24	610	4 <sup>1</sup> / <sub>4</sub>	2.0	<b>2WD24S</b>

For MetroMax i Open Frame and Drop-In Basket, see page 27.

**NSF** Note: Wall shelving is NSF listed.

**MetroMax i® Corner Adapter Kit**

Order one kit per MetroMax i shelf or shelf frame.

Cat. No. **M9997-4**

**Wall Mounts**

An ideal method for storing items overhead or above work surfaces.

- Brackets accommodate all Super Erecta® sizes and types of shelves.
- Use double supports to mount adjacent shelves, single supports at ends.
- Metal caps to cover openings are provided.
- Available in chrome, Metroseal 3 or stainless steel.

**Post-Type Wall Mounts — 10.40**

**Standard Units**

Post-type wall mounts are available in pre-packaged “End Units” and “Mid Units; complete with all needed components except shelves, wall bolts or screws, which must be selected according to type of wall. \*Shelf supports are chrome-plated.

- A** “End Unit” consists of two posts with wall mounting brackets, and two single shelf supports for each shelf level.
- B** “Mid Unit” consists of one post with brackets and double support for each shelf.

If shelving is to be the length of one shelf, order End Unit only.

If two-shelf lengths, order one End Unit and one Mid Unit; three lengths, one End and two Mid Units; four lengths, one End and three Mid Units; etc.

**For 14" (355mm) Shelf Width**

Shelf Levels	Approx. Pkd. Wt.		Cat. No. End Unit	Approx. Pkd. Wt.		Cat. No. Mid Unit
	(lbs.)	(kg)		(lbs.)	(kg)	
1	7	3.2	<b>SW21C</b>	5	2.3	<b>AW21C</b>
2	14	6.4	<b>SW23C</b>	9	4.1	<b>AW23C</b>
3	22	10	<b>SW25C</b>	14	6.4	<b>AW25C</b>
4	28	12.7	<b>SW26C</b>	18	8.2	<b>AW26C</b>

**For 18" (457mm) Shelf Width**

Shelf Levels	Approx. Pkd. Wt.		Cat. No. End Unit	Approx. Pkd. Wt.		Cat. No. Mid Unit
	(lbs.)	(kg)		(lbs.)	(kg)	
1	7	3.2	<b>SW31C</b>	5	2.3	<b>AW31C</b>
2	14	6.4	<b>SW33C</b>	11	5	<b>AW33C</b>
3	22	10	<b>SW35C</b>	17	8	<b>AW35C</b>
4	28	12.7	<b>SW36C</b>	21	9.5	<b>AW36C</b>

**For 21" (530mm) Shelf Width**

Shelf Levels	Approx. Pkd. Wt.		Cat. No. End Unit	Approx. Pkd. Wt.		Cat. No. Mid Unit
	(lbs.)	(kg)		(lbs.)	(kg)	
1	8	3.6	<b>SW41C</b>	6	2.7	<b>AW41C</b>
2	16	7.3	<b>SW43C</b>	12	5.5	<b>AW43C</b>
3	25	11.3	<b>SW45C</b>	18	8.2	<b>AW45C</b>
4	32	14.4	<b>SW46C</b>	23	10.4	<b>AW46C</b>

**For 24" (610mm) Shelf Width**

Shelf Levels	Approx. Pkd. Wt.		Cat. No. End Unit	Approx. Pkd. Wt.		Cat. No. Mid Unit
	(lbs.)	(kg)		(lbs.)	(kg)	
1	9	4.1	<b>SW51C</b>	6	2.7	<b>AW51C</b>
2	18	8.2	<b>SW53C</b>	12	5.5	<b>AW53C</b>
3	28	12.7	<b>SW55C</b>	19	9	<b>AW55C</b>
4	36	16	<b>SW56C</b>	24	10.9	<b>AW56C</b>

**\*Note:** User should determine that wall material and method of mounting are suitable to support the shelves and their contents. Mounting hardware not included.

Maximum Load Rating: 250 lbs. (113kg) per shelf, not to exceed 250 lbs. (113kg) per unit.

See page 42 for Super Erecta shelves.



Post-Type Wall Mount Installation



Post-Type Wall Mounts

**Metro Tip:**  
Have you looked at your walls lately? Unused wall space provides the perfect opportunity for a significant increase in storage capacity. Metro offers a complete line of wall shelving systems to maximize storage density.



## Posts and Brackets — 10.40

Two end brackets (BES) are supplied with each of these double-footed posts. One intermediate bracket (BCS) is supplied with 33PDF posts and two are supplied with 54PDF and 63PDF posts. Order desired number/style of shelf supports below.

Post Height (in.) (mm)	Description	Approx. Pkd. Wt. (lbs.) (kg)	Cat. No. Chrome	Cat. No. Metroseal 3 with Microban®	Cat. No. Stainless
13 <sup>7</sup> / <sub>8</sub> 350	Post for 1 tier	1 <sup>1</sup> / <sub>4</sub> 0.6	13PDF	13PDFK3	13PDFS
33 <sup>5</sup> / <sub>8</sub> 854	Post for 2 tiers	2 <sup>3</sup> / <sub>4</sub> 1.2	33PDF	33PDFK3	33PDFS
54 1370	Post for 3 or more tiers	5 2.3	54PDF	54PDFK3	54PDFS
62 1573	Post for 4 or more tiers	6 2.7	63PDF	63PDFK3	63PDFS
	End Bracket	1 <sup>1</sup> / <sub>2</sub> 0.2	BES	BESK3	SBES
	Intermediate Bracket	1 <sup>1</sup> / <sub>2</sub> 0.2	BCS	BCSK3	SBCS

**Note:** User should determine that wall material and method of mounting are suitable to support the shelves and their contents. Mounting hardware not included. Order shelves from page 42.

## Corner Adapters for MetroMax i shelving

Use when joining MetroMax i shelves with wire shelf supports. Box of 4. Use one box per shelf. Cat. No. **M9997-4**

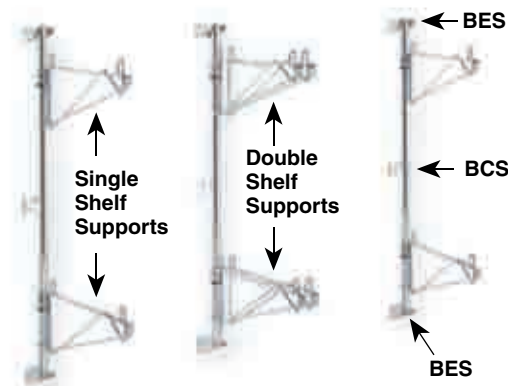

Typical configuration using two end units and one mid unit

Maximum Load Rating:  
250 lbs. (113kg) per shelf,  
not to exceed 250 lbs.  
(113kg) per unit.

See page 42 for Super Erecta shelves.

## Metro Tip:

MetroMax Q and MetroMax i shelves can be used with Super Erecta Post Mounting Shelf Supports and Direct Wall Mounts.

## Shelf Supports — Post Mounting — 10.40

Single —  
Two required per shelf (one at each end.)

Shelf Width (in.) (mm)	Approx. Pkd. Wt. (lbs.) (kg)	Cat. No. Chrome	Cat. No. Metroseal 3 with Microban®	Cat. No. Stainless
14 355	2 0.9	1WS14C	1WS14K3	1WS14S
18 457	2 0.9	1WS18C	1WS18K3	1WS18S
21 530	2 <sup>1</sup> / <sub>2</sub> 1.1	1WS21C	1WS21K3	1WS21S
24 610	3 1.4	1WS24C	1WS24K3	1WS24S

Double —  
For run of multiple shelves.

Shelf Width (in.) (mm)	Approx. Pkd. Wt. (lbs.) (kg)	Cat. No. Chrome	Cat. No. Metroseal 3 with Microban®	Cat. No. Stainless
14 355	3 1.4	2WS14C	2WS14K3	2WS14S
18 457	3 <sup>3</sup> / <sub>4</sub> 1.7	2WS18C	2WS18K3	2WS18S
21 530	4 <sup>1</sup> / <sub>4</sub> 1.9	2WS21C	2WS21K3	2WS21S
24 610	4 <sup>1</sup> / <sub>2</sub> 2.0	2WS24C	2WS24K3	2WS24S

Order shelves from page 42.

## Direct Wall Mounts — 10.40

Each consists of one shelf support and mounting plate, with two shelf collar caps. Use single support at shelf ends; double support for adjoining shelves.

Single — Two required per shelf.

Shelf Width (in.) (mm)	Approx. Pkd. Wt. (lbs.) (kg)	Cat. No. Chrome	Cat. No. Metroseal 3 with Microban®	Cat. No. Stainless
14 355	1 <sup>1</sup> / <sub>2</sub> 0.7	1WD14C	1WD14K3	1WD14S
18 457	2 0.9	1WD18C	1WD18K3	1WD18S
21 530	2 0.9	1WD21C	1WD21K3	1WD21S
24 610	2 <sup>1</sup> / <sub>4</sub> 1.0	1WD24C	1WD24K3	1WD24S

Double

Shelf Width (in.) (mm)	Approx. Pkd. Wt. (lbs.) (kg)	Cat. No. Chrome	Cat. No. Metroseal 3 with Microban®	Cat. No. Stainless
14 355	3 1.4	2WD14C	2WD14K3	2WD14S
18 457	3 1.4	2WD18C	2WD18K3	2WD18S
21 530	4 1.8	2WD21C	2WD21K3	2WD21S
24 610	4 <sup>1</sup> / <sub>2</sub> 2.0	2WD24C	2WD24K3	2WD24S

**Note:** User should determine that wall material and method of mounting are suitable to support the shelves and their contents.



Single Shelf Support



Double Shelf Support



## Hole Plugs — 10.06

This chrome-plated cover is used to fill shelf-corner openings. Use wherever posts have been eliminated by "S" hooks.

Cat. No. **9997C**

✓ Indicates antimicrobial product.

# Push ahead.

Give yourself the versatility you need with Metro Utility Carts.

## Premium Polymer Utility Carts

- Can be used in a variety of unique transport applications.
- Durable materials, ergonomic handles, and premium casters promote long life and ease of use.
- Microban product protection built into the shelf mats, frames, and posts.
- Easier to clean with removable shelf mats.

## MetroMax i® Utility Carts

- Corrosion proof shelves, posts, and Type 304 stainless steel handle.
- Corrosion resistant 5PCX casters with 5" (127mm) polyurethane wheels, polymer horns, and stainless steel axles.
- 39<sup>1</sup>/<sub>4</sub>" (997mm) tall. Weight capacity of cart: 900 lbs. (408kg) evenly distributed.

Nominal Width/Length (in.) (mm)		Actual Width/Length (in.) (mm)		Description	Approx. Pkd. Wt. (lbs.) (kg)		Cat. No.
18x30	457x760	20 <sup>5</sup> / <sub>16</sub> x34 <sup>1</sup> / <sub>2</sub>	516x876		2-shelf	35.5	
24x36	610x914	26 <sup>5</sup> / <sub>16</sub> x40 <sup>1</sup> / <sub>2</sub>	668x1029	2-shelf	46.0	20.5	<b>MXUC2436G-25</b>
18x30	457x760	20 <sup>5</sup> / <sub>16</sub> x34 <sup>1</sup> / <sub>2</sub>	516x876	3-shelf	46.0	20.5	<b>MXUC1830G-35</b>
24x36	610x914	26 <sup>5</sup> / <sub>16</sub> x40 <sup>1</sup> / <sub>2</sub>	668x1029	3-shelf	61.5	27.5	<b>MXUC2436G-35</b>



## MetroMax Q® Utility Carts

- Quick adjust corrosion resistant shelves and posts.
- Corrosion proof Type 304 stainless steel handle.
- Includes four 5MPX casters with 5" (127mm) polyurethane wheels.
- 39<sup>1</sup>/<sub>4</sub>" (997mm) tall. Weight capacity of cart: 900 lbs. (408kg) evenly distributed.

Nominal Width/Length (in.) (mm)		Actual Width/Length (in.) (mm)		Description	Approx. Pkd. Wt. (lbs.) (kg)		Cat. No.
18x30	457x760	20 <sup>5</sup> / <sub>16</sub> x34 <sup>1</sup> / <sub>2</sub>	16x876		2-shelf	35.5	
24x36	610x914	26 <sup>5</sup> / <sub>16</sub> x40 <sup>1</sup> / <sub>2</sub>	668x1029	2-shelf	46.0	20.5	<b>MQUC2436G-25</b>
18x30	457x760	20 <sup>5</sup> / <sub>16</sub> x34 <sup>1</sup> / <sub>2</sub>	516x876	3-shelf	46.0	20.5	<b>MQUC1830G-35</b>
24x36	610x914	26 <sup>5</sup> / <sub>16</sub> x40 <sup>1</sup> / <sub>2</sub>	668x1029	3-shelf	61.5	27.5	<b>MQUC2436G-35</b>



## Helpful Hints

- Configure a cart to your exact needs using a combination of MetroMax i® and Q™ shelves and posts.
- Consider MetroMax i solid shelves when spill containment is required or to protect supplies from dirt during transport.
- A typical utility cart will be configured using 27" (685mm) or 33" (875mm) stem caster posts with 5" (127mm) casters.

**Shelves and posts: pages 14-15 Casters: page 16 Handles: page 17**



Solid bottom shelf and 5PCX/5PCBX casters pictured

# This is myCart... get your own.

## myCart Series™

Designed for your transport needs...  
making every step count.

Corrosion proof  
& impact resistant  
polymer shelves.

Easy to clean  
surface

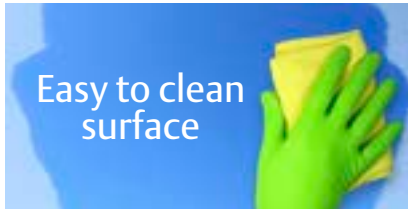

Personalization Label



## Better Containment!

Ship's edge retains small spills  
and prevents items from sliding  
off during transport.

## Easy & Useful

Easy-grip handle  
and roomy  
utility tray



## More Legroom!

50% more legroom than  
conventional carts!  
You won't hit your shins  
or kick the cart!

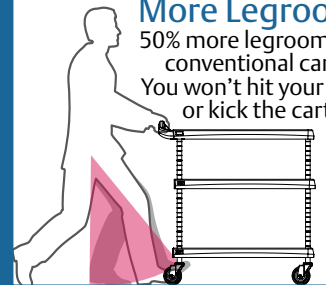

## Cleanable

- > NSF Listed.
- > Smooth surfaces easily wipe clean and won't stain.
- > Specific models available with Microban® Antimicrobial product protection.

## Durable

- > Corrosion proof, impact resistant shelves are designed to withstand daily abuse.
- > Sturdy construction: 300 lb. (136kg), 400 lb. (181kg), and 500 lb. (227kg) capacity models available.

## User Friendly

- > Additional legroom puts more distance between the shelves and you. You can push the cart more freely without hitting your shins and feet off the cart.
- > Right-sized for common containers and racks.
- > Large covered utility tray organizes small items and easily wipes clean.
- > Easy-grip handle and four swivel casters ensure easy maneuvering.
- > Each cart comes with two personalization labels for easy identification.

**myCart Series™ — 12.29**

- > Available in 2-shelf and 3-shelf configurations.
- > 7/16" (11mm) deep ship's edge lip around shelf perimeter.
- > MY1627 and MY2030 Base Model specs: Chrome posts, 4" (102mm) non-marking swivel casters. 150 lbs. (68kg) capacity per shelf.
- > MY2636 Base Model specs: Chrome posts, 5" (127mm) swivel resilient rubber casters, 200 lbs. (90kg) capacity per shelf.
- > MY1627 Upgrade Model specs: Blue shelves with built-in Microban antimicrobial product protection, type 304 stainless steel posts, 4" (102mm) non-marking swivel casters, 150 lbs. (68kg) capacity per shelf.

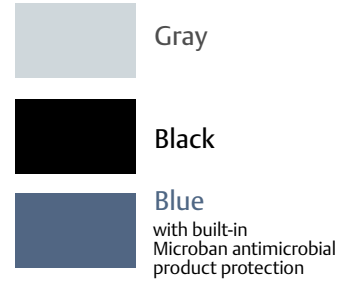

**Carts**

Width/Length/Height		Description	Load Rating Per Cart		Approx. Pkd. Wt.		Cat. No. Gray	Cat. No. Black	Cat. No. Blue with Antimicrobial
(in.)	(mm)		(lbs.)	(kg)	(lbs.)	(kg)			
18 <sup>5</sup> / <sub>16</sub> x 31 <sup>1</sup> / <sub>2</sub> x 35 <sup>1</sup> / <sub>2</sub>	465x800x902	2-shelf base model	300	136	28.5	12.9	MY1627-24G	MY1627-24BL	MY1627-24BU
18 <sup>5</sup> / <sub>16</sub> x 31 <sup>1</sup> / <sub>2</sub> x 35 <sup>1</sup> / <sub>2</sub>	465x800x902	3-shelf base model	400	181	34	15.4	MY1627-34G	MY1627-34BL	MY1627-34BU
23 <sup>7</sup> / <sub>16</sub> x 34 <sup>3</sup> / <sub>8</sub> x 35 <sup>1</sup> / <sub>2</sub>	595x873x902	2-shelf base model	300	136	33	15	MY2030-24G	MY2030-24BL	MY2030-24BU
23 <sup>7</sup> / <sub>16</sub> x 34 <sup>3</sup> / <sub>8</sub> x 35 <sup>1</sup> / <sub>2</sub>	595x873x902	3-shelf base model	400	181	41.5	19	MY2030-34G	MY2030-34BL	MY2030-34BU
27 <sup>1</sup> / <sub>16</sub> x 40 <sup>1</sup> / <sub>4</sub> x 36 <sup>7</sup> / <sub>8</sub>	703x1022x937	2-shelf base model	400	181	40	18.1	MY2636-25G	MY2636-25BL	MY2636-25BU
27 <sup>1</sup> / <sub>16</sub> x 40 <sup>1</sup> / <sub>4</sub> x 36 <sup>7</sup> / <sub>8</sub>	703x1022x937	3-shelf base model	500	227	51	23.1	MY2636-35G	MY2636-35BL	MY2636-35BU
18 <sup>5</sup> / <sub>16</sub> x 31 <sup>1</sup> / <sub>2</sub> x 35 <sup>1</sup> / <sub>2</sub>	465x800x902	2-shelf cart, upgrade	300	136	28.5	12.9	-	-	MY1627-24BU-SS
18 <sup>5</sup> / <sub>16</sub> x 31 <sup>1</sup> / <sub>2</sub> x 35 <sup>1</sup> / <sub>2</sub>	465x800x902	3-shelf cart, upgrade	400	181	34	15.4	-	-	MY1627-34BU-SS

**Accessories**

> Utility bin and wastebasket can be easily removed from their holders to empty contents or for routine cleaning.

Width/Height/Depth		Description	Fits Cart	Load Rating		Approx. Pkd. Wt.		Cat. No.
(in.)	(mm)			(lbs.)	(kg)	(lbs.)	(kg)	
17 <sup>7</sup> / <sub>8</sub> x 16 <sup>1</sup> / <sub>4</sub> x 14 <sup>3</sup> / <sub>4</sub>	454x413x375	Wastebasket + Holder	MY1627	25	11.3	5.7	2.5	MYWB1
23 x 16 <sup>1</sup> / <sub>4</sub> x 14 <sup>3</sup> / <sub>4</sub>	584x413x375	Wastebasket + Holder	MY2030	25	11.3	5.8	2.6	MYWB2
14 <sup>3</sup> / <sub>8</sub> x 15 <sup>3</sup> / <sub>8</sub> x 10 <sup>3</sup> / <sub>8</sub>	365x391x264	Wastebasket Only				2.8	1.3	MF222
17 <sup>3</sup> / <sub>8</sub> x 7 x 15 <sup>1</sup> / <sub>4</sub>	454x178x387	Utility Bin + Holder	MY1627	25	11.3	5	2.2	MYUB1
23 x 7 x 15 <sup>1</sup> / <sub>4</sub>	584x178x387	Utility Bin + Holder	MY2030	25	11.3	5.1	2.3	MYUB2
16 <sup>3</sup> / <sub>8</sub> x 6 x 11	416x152x279	Utility Bin Only				2	0.9	UB1



Utility Bin and Holder



Wastebasket and Holder

**Personalization Labels**

Personalization labels provide easy identification

- > Constructed of polyester material with a clear polyester flap to protect written information from wiping off.

4 3/8" L x 7 7/8" H (117.5x22.4mm)

Cat. No. **MYCARTLBL-10PK** Pack of 10



**Replacement Casters**

4" (102mm) non-marking swivel caster. Used with MY1627 and MY2030 models.

Cat. No. **RPBC4M-4**, bag of four.

5" (127mm) swivel resilient rubber caster. Used with MY2636 models.

Cat. No. **5M**, sold individually.



**16x27**

**Easy-grip handle and utility tray**

- > Small footprint for tight spaces.
- > Accommodates Metro tote boxes and ISO totes.

MY1627



**20x30**

**MY2030 cart handle has built-in recessed support channel to manage odd shaped items.**

- > Right-sized to fit : Glass & dish racks, bussing totes, silverware bins, milk crates.

MY2030



**26x36**

**MY2636 cart handle has a built-in slot to hold scanners and labelers.**

- > Ideal for large bulky items. 5" (127mm) Caster makes cart easier to maneuver. 3-shelf model holds up to 500 lbs.

MY2636



Available in blue colored myCart.

Indicates antimicrobial product.



Weight load capacity for Deep Ledge series.  
 150 lbs. (68kg) per shelf.  
 2-shelf model: 300 lbs. (136kg)  
 3-shelf model: 400 lbs. (181kg)



Gray



Blue



Black



Slate Blue  
 (with Microban product protection)



Deep Ledge Utility Carts — 12.28 NSF

Specially designed with a 2<sup>3</sup>/<sub>4</sub>" (70mm) deep ledge to contain product and spills.

- Polymer shelves are easy to clean and corrosion proof.
- Available colors are gray, black, blue and slate blue. Slate blue contains Microban antimicrobial product protection.
- Available in 2-shelf and 3-shelf models.
- Center shelf option adjusts at 1" (25mm) increments.

Width/Length/Height (in.)	Width/Length/Height (mm)	Description	Approx. Pkd. Wt. (lbs.) (kg)		Cat. No.*	Cat. No. Slate Blue with Microban
21 <sup>1</sup> / <sub>2</sub> x33 <sup>3</sup> / <sub>4</sub> x33 <sup>1</sup> / <sub>4</sub>	546x857x845	2-shelf unit	29	31.1	BC2030-2D	BC2030-2DMB
21 <sup>1</sup> / <sub>2</sub> x33 <sup>3</sup> / <sub>4</sub> x33 <sup>1</sup> / <sub>4</sub>	546x857x845	3-shelf unit	37 <sup>1</sup> / <sub>2</sub>	17.0	BC2030-3D	BC2030-3DMB
27x39 <sup>1</sup> / <sub>2</sub> x33 <sup>1</sup> / <sub>4</sub>	685x1003x845	2-shelf unit	35	15.9	BC2636-2D	
27x39 <sup>1</sup> / <sub>2</sub> x33 <sup>1</sup> / <sub>4</sub>	685x1003x845	3-shelf unit	46 <sup>1</sup> / <sub>2</sub>	21.1	BC2636-3D	

\*Add color designation to part number when ordering: Gray (G), Black (BL) and Blue (BU).  
 Example: BC2030-3DG = 3-shelf gray cart.



Accessories and Replacement Casters — 12.28

- Utility Bin and Wastebasket can be easily removed from the holders to empty contents or for routine cleaning.

Description	Fits Cart	Width/Height/Depth (in.)	Width/Height/Depth (mm)	Approx. Pkd. Wt. (lbs.) (kg)		Deep Ledge Cat. No.
Wastebasket + Holder	BC2030	21 <sup>1</sup> / <sub>4</sub> x27 <sup>1</sup> / <sub>2</sub> x13 <sup>1</sup> / <sub>4</sub>	540x700x337	8.0	3.8	BCWB2D
Utility Bin + Holder	BC2030	21 <sup>1</sup> / <sub>4</sub> x7 <sup>3</sup> / <sub>4</sub> x14 <sup>1</sup> / <sub>2</sub>	540x197x368	6.0	2.7	BCUB2D
Wastebasket Only		14 <sup>3</sup> / <sub>8</sub> x15 <sup>5</sup> / <sub>8</sub> x10 <sup>3</sup> / <sub>8</sub>	365x391x264	2.8	1.3	MF222
Utility Bin Only		16 <sup>3</sup> / <sub>8</sub> x6x11	416x152x279	2.0	0.9	UB1
Replacement Caster Kit — All						RPBC4M-4

Note: Caster kit contains four 4" (102mm) swivel casters.



\*MICROBAN® and the MICROBAN® symbol are registered trademarks of the Microban Products Company, Huntersville, NC.

## Basket Cart



Includes two light-duty basket style shelves, one standard wire shelf, four posts, extended handle, and four 4" diameter swivel casters (two with brakes)

- Basket shelves have a 3 1/2" (89mm) high edge to secure contents during transport.
- Durable chrome finish
- 400 lbs. (182kg) capacity per cart; 150 lbs. (68kg) capacity per shelf
- Ships in one box

Shelf Width/Length (in.) (mm)		Overall Length (including handle) (in.) (mm)		Overall Height (in.) (mm)		Approx. Pkd. Wt. (lbs.) (kg)		Cat. No.
18x36	457x914	39 7/8	1013	40 1/8	1020	49	22	<b>BASCART-SR</b>



Basket Cart

## Basket Shelves – Regular Duty

- 3 1/2" (89mm) deep basket with 400 lb. (182kg) weight capacity
- Ideal for containing and displaying smaller items.

Size (in.) (mm)		Cat. No. Chrome	Cat. No. Black
14x36	355x914	—	<b>DD3448A</b>
14x48	355x1219	—	<b>DD3448B</b>
18x36	457x914	<b>CC9744A</b>	<b>CC9744C</b>
18x48	457x1219	<b>CC9744</b>	<b>CC9744B</b>

Shelf Width/Length (in.) (mm)		Approx. Pkd. Wt. (lbs.) (kg)		Cat. No. Chrome	Cat. No. Black
14x36	355x914	8	3.6	<b>1436NC</b>	<b>1436NBL</b>
14x48	355x1219	9 1/2	4.3	<b>1448NC</b>	<b>1448NBL</b>
18x36	457x914	9 1/2	4.3	<b>1836NC</b>	<b>1836NBL</b>
18x48	457x1219	12	5.4	<b>1848NC</b>	<b>1848NBL</b>

Post Height (in.) (mm)		Approx. Pkd. Wt. (lbs.) (kg)		Cat. No. Chrome	Cat. No. Black
27 1/2	699	1 3/4	0.75	<b>27UP</b>	<b>27UPBL</b>
34 1/2	875	2	0.9	<b>33UP</b>	<b>33UPBL</b>
54 9/16	1385	3	1.4	<b>54UP</b>	<b>54UPBL</b>

Handle Length (in.) (mm)		Cat. No. Chrome
14	355	<b>EH14NC</b>
18	457	<b>EH18NC</b>

Casters Diameter (in.) (mm)		Approx. Pkd. Wt. (lbs.) (kg)		Cat. No.
4	102	1 1/2	0.6	<b>4LD</b>
5	127	2 1/2	1.1	<b>5M</b>
5	127	2 1/8	0.94	<b>5MP</b>



Basket Shelves

Unit shown consists of:

- (2) CC9744A
- (4) 27UPBL
- (2) 5MP
- (2) 5MPB

Mix and Match basket shelves with these Super Erecta components to customize a cart.



MW200 Series

MW Series Utility Carts — 12.01 NSF

- Consist of Super Erecta wire shelves with plastic split sleeves, two one-piece handles of matching finish, and designated casters with donut bumpers.
- Two- and three-tier models available.
- 375 lbs. (170kg) weight capacity per cart. MW carts use light-duty resilient casters.
- 18" (457mm) wide carts have 4" (102mm) casters. Cart is 38" (965mm) high.
- 21" and 24" (530 and 610mm) wide carts have 5" (127mm) casters. Cart is 39" (990mm) high.

Utility Carts with Stainless Steel Solid Shelves

Width/Length (in.) (mm)		Approx. Pkd. Wt. (lbs.) (kg)		Cat. No. 2-Shelf	Approx. Pkd. Wt. (lbs.) (kg)		Cat. No. 3-Shelf
18x24	457x610	40	18.1	<b>MW103</b>	48	21.8	<b>MW203</b>
18x30	457x760	45	20.4	<b>MW104</b>	53	24.0	<b>MW204</b>
18x36	457x914	48	21.8	<b>MW105</b>	59	26.8	<b>MW205</b>
21x36	530x914	54	24.5	<b>MW106</b>	74	33.6	<b>MW206</b>
24x36	610x914	60	27.2	<b>MW108</b>	66	29.9	<b>MW208</b>



MW400 Series

Utility Carts with 1 Solid, 2 Wire Shelves

Width/Length (in.) (mm)		Approx. Pkd. Wt. (lbs.) (kg)		Shelf Material	Handles	Cat. No.
18x24	457x610	43	19.5	Stainless Steel, Chrome	Chrome	<b>MW401</b>
18x30	457x760	47	21.3	Stainless Steel, Chrome	Chrome	<b>MW402</b>
18x36	457x914	52	23.6	Stainless Steel, Chrome	Chrome	<b>MW403</b>
21x36	530x914	59	26.8	Stainless Steel, Chrome	Chrome	<b>MW404</b>
24x36	610x914	65	29.5	Stainless Steel, Chrome	Chrome	<b>MW406</b>



MW600 Series

Utility Carts with 2 Wire Shelves

Width/Length (in.) (mm)		Approx. Pkd. Wt. (lbs.) (kg)		Shelf Material	Handles	Cat. No.
18x24	457x610	34	15.4	Chrome	Chrome	<b>MW601</b>
18x24	457x610	34	15.4	Stainless Steel	Stainless Steel	<b>MW602</b>
18x30	457x760	37	16.8	Chrome	Chrome	<b>MW603</b>
18x30	457x760	37	16.8	Stainless Steel	Stainless Steel	<b>MW604</b>
18x36	457x914	40	18.1	Chrome	Chrome	<b>MW605</b>
18x36	457x914	39	17.7	Stainless Steel	Stainless Steel	<b>MW606</b>
21x36	530x914	44	20.0	Chrome	Chrome	<b>MW607</b>
21x36	530x914	44	20.0	Stainless Steel	Stainless Steel	<b>MW608</b>
24x36	610x914	47	21.3	Chrome	Chrome	<b>MW611</b>
24x36	610x914	46	20.9	Stainless Steel	Stainless Steel	<b>MW612</b>



MW700 Series

Utility Carts with 3 Wire Shelves

Width/Length (in.) (mm)		Approx. Pkd. Wt. (lbs.) (kg)		Shelf Material	Handles	Cat. No.
18x24	457x610	39	17.6	Chrome	Chrome	<b>MW701</b>
18x24	457x610	38	17.2	Stainless Steel	Stainless Steel	<b>MW702</b>
18x30	457x760	43	19.5	Chrome	Chrome	<b>MW703</b>
18x30	457x760	42	19.1	Stainless Steel	Stainless Steel	<b>MW704</b>
18x36	457x914	47	21.3	Chrome	Chrome	<b>MW705</b>
18x36	457x914	45	20.4	Stainless Steel	Stainless Steel	<b>MW706</b>
21x36	530x914	50	22.7	Chrome	Chrome	<b>MW707</b>
21x36	530x914	50	22.7	Stainless Steel	Stainless Steel	<b>MW708</b>
24x36	610x914	60	27.7	Chrome	Chrome	<b>MW711</b>
24x36	610x914	57	25.9	Stainless Steel	Stainless Steel	<b>MW712</b>

## SP Series Utility Carts — 12.10 **NSF**

- Consist of Super Erecta wire shelves with plastic split sleeves, two one-piece handles of matching finish, and designated casters with donut bumpers.
- Two- and three-tier models available.
- 5" (127mm) casters allow for transport of heavier loads than the MW Series Carts.
- 39" (990mm) high.



2-Tier with 5M casters

Super Erecta Brite finish — 600 lbs. (273kg) capacity per cart

- 5M Resilient Rubber Casters; casters have plated horns and axles.

Shelf Width/Length (in.)	Shelf Width/Length (mm)	2-TIER MODELS		3-TIER MODELS	
		Approx. Pkd. Wt. (lbs.) (kg)	Cat. No. Super Erecta Brite	Approx. Pkd. Wt. (lbs.) (kg)	Cat. No. Super Erecta Brite
18x36	457x914	40 18	<b>2SPN33ABR</b>	50 22.5	<b>3SPN33ABR</b>
21x36	530x914	44 20	<b>2SPN43ABR</b>	55 24.7	<b>3SPN43ABR</b>
24x36	610x914	48 22	<b>2SPN53ABR</b>	61 27.4	<b>3SPN53ABR</b>
24x48	610x1219	54 24	<b>2SPN55ABR</b>	70 31.5	<b>3SPN55ABR</b>
24x60	610x1524	64 29	<b>2SPN56ABR</b>	85 38.2	<b>3SPN56ABR</b>



3-Tier with 5MP casters

Chrome finish — 900 lbs. (410kg) capacity per cart

- 5MP Polyurethane Casters; casters have plated horns and axles.

Shelf Width/Length (in.)	Shelf Width/Length (mm)	2-TIER MODELS		3-TIER MODELS	
		Approx. Pkd. Wt. (lbs.) (kg)	Cat. No. Chrome	Approx. Pkd. Wt. (lbs.) (kg)	Cat. No. Chrome
18x36	457x914	40 18	<b>2SPN33DC</b>	50 22.5	<b>3SPN33DC</b>
21x36	530x914	44 20	<b>2SPN43DC</b>	55 24.7	<b>3SPN43DC</b>
24x36	610x914	48 22	<b>2SPN53DC</b>	61 27.4	<b>3SPN53DC</b>
24x48	610x1219	54 24	<b>2SPN55DC</b>	70 31.5	<b>3SPN55DC</b>
24x60	610x1524	64 29	<b>2SPN56DC</b>	85 38.2	<b>3SPN56DC</b>



3-Tier with 5PC casters

Type 304 Stainless Steel — 900 lbs. (410kg) capacity per cart

- 5PC Polyurethane Casters; casters have polymer horns and stainless steel ax

Shelf Width/Length (in.)	Shelf Width/Length (mm)	2-TIER MODELS		3-TIER MODELS	
		Approx. Pkd. Wt. (lbs.) (kg)	Cat. No. Stainless Steel	Approx. Pkd. Wt. (lbs.) (kg)	Cat. No. Stainless Steel
18x36	457x914	40 18	<b>2SPN33PS</b>	50 22.5	<b>3SPN33PS</b>
21x36	530x914	44 20	<b>2SPN43PS</b>	55 24.7	<b>3SPN43PS</b>
24x36	610x914	48 22	<b>2SPN53PS</b>	61 27.4	<b>3SPN53PS</b>
24x48	610x1219	54 24	<b>2SPN55PS</b>	70 31.5	<b>3SPN55PS</b>
24x60	610x1524	64 29	<b>2SPN56PS</b>	85 38.2	<b>3SPN56PS</b>

## One-Piece Handles — 12.20

May be used with Super Erecta shelving, casters, and components to customize a cart to your exact needs.

Shelf Width/Length (in.)	Shelf Width/Length (mm)	Approx. Pkd. Wt. (lbs.) (kg)	Cat. No. Chrome	Cat. No. Stainless Steel
18	457	5½ 2.5	<b>H3C</b>	<b>H3S</b>
21	533	5¾ 2.6	<b>H4C</b>	<b>H4S</b>
24	610	6 2.7	<b>H5C</b>	<b>H5S</b>

Height: 34½" (876mm).



One-Piece Handle



# HIGH-DENSITY STORAGE, DUNNAGE & SECURITY

High-Density Movable Aisle Shelving .....	92-99
Vertical High-Density Shelving .....	100
Dunnage Racks & Shelves .....	101-102
Security Storage.....	103-107
Seismic Shelving .....	108-109

# So smart...

## qwikTRAK® High-Density Storage



BOOST  
STORAGE SPACE  
BY UP TO  
**50%**  
WITH NO ADDED  
CONSTRUCTION  
COSTS.

### qwikTRAK key facts

The aluminum and stainless steel floor tracks provide a smooth, gliding surface for mobile units.

- Mobile units are designed to move easily and store heavy weight loads. MetroMax i mobile qwikTRAK units can hold up to 1,200 lbs. (544kg). MetroMax Q, Super Adjustable, and Super Erecta mobile qwikTRAK units can hold up to 2,000 lbs. (907kg).
- Floor tracks protect the floors from wear and tear and do not require to be mounted to the floor.
- Floor tracks compensate for rough or choppy floor surfaces.

Double-Deep Configurations can be created where two systems are joined together to increase the overall depth of the storage system for even greater storage capacity.

Choose the shelving type based on the application.

Both single- and double-deep systems can be used with Metro wire shelving (Super Erecta or Super Adjustable Super Erecta) and polymer shelving systems (MetroMax i and MetroMax Q).



THE SECRET TO  
HIGH-DENSITY  
STORAGE IS THE  
**ACTIVE  
AISLE**  
CONCEPT.

# it's dense.

## Top-Track® High-Density Storage



**ADA Compliant**



### Top-Track key facts

The guide track is positioned above the shelving system.

- Floors are easy to clean.
- Utility carts can easily be rolled into and out of the active aisle.
- The guide track compensates for uneven floor surfaces and keeps units in alignment.
- Mobile units are designed to address medium-duty applications. The weight capacity of a Top-Track mobile unit is 900 lb. (410kg).

Choose the shelving type based on your application.

Top-Track (single deep) can be used with Metro wire shelving (Super Erecta or Super Adjustable Super Erecta) and polymer shelving systems (MetroMax i and MetroMax Q).

Double-Deep configurations can be created when two systems are joined together to increase the overall depth of the storage system for even greater storage capacity. Double-Deep Top-Track is only available for Super Erecta and Super Adjustable Super Erecta style shelving.



HIGH DENSITY STORAGE . . . THE SMART WAY TO PUT SPACE TO WORK.

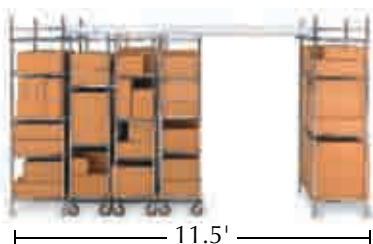



High-Density qwikTRAK® Storage Systems for: Super Erecta, Super Erecta Pro,™ Super Adjustable, MetroMax Q, and MetroMax i Systems.



MetroMax i qwikTRAK

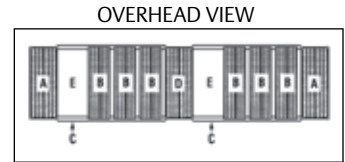
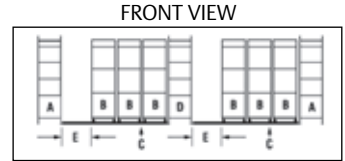

SYSTEM COMPONENTS

- A = Stationary End Units
- B = Mobile Units
- C = qwikTRAK
- D = Stationary Intermediate Unit
- E = Active Aisle



Grooved casters fit securely on track.

Shelves Sold Separately  
 Super Erecta — Pg. 42  
 Super Erecta Pro — Pg. 34  
 Super Adjustable — Pg. 37  
 MetroMax Q — Pg. 15  
 MetroMax i — Pg. 14

qwikTRAK Storage System — 11.15

Stationary End Unit Kits

Includes 74" high posts (1880mm) high stationary posts, and hardware necessary for connecting stationary end units to tracks and anchoring tracks to the floor. Order one kit per system. Shelves are sold separately.

Super Erecta, Super Erecta Pro, Super Adjustable Super Erecta				MetroMax Q		MetroMax i	
Approx. Pkd. Wt. (lbs.)	Approx. Pkd. Wt. (kg)	Cat. No. Chrome-Plated	Cat. No. Metroseal 3 with Microban®	Cat. No. Stainless Steel	Approx. Pkd. Wt. (lbs.)	Approx. Pkd. Wt. (kg)	Cat. No.
39.6	18.0	<b>BTEC</b>	<b>BTEK3</b>	<b>BTES</b>	42.0	19.1	<b>BTEQ3</b>
							25.0 11.4 <b>BTEX3</b>

Stationary Intermediate Unit Kits

Includes 74" high posts (1880mm) high stationary posts, and hardware necessary for connecting one stationary intermediate unit to tracks and anchoring tracks to the floor. Shelves are sold separately.

Super Erecta, Super Erecta Pro, Super Adjustable Super Erecta				MetroMax Q		MetroMax i	
Approx. Pkd. Wt. (lbs.)	Approx. Pkd. Wt. (kg)	Cat. No. Chrome-Plated	Cat. No. Metroseal 3 with Microban®	Cat. No. Stainless Steel	Approx. Pkd. Wt. (lbs.)	Approx. Pkd. Wt. (kg)	Cat. No.
22.6	10.3	<b>BTAC</b>	<b>BTAK3</b>	<b>BTAS</b>	24.2	11.0	<b>BTAQ3</b>
							15.7 7.1 <b>BTAX3</b>

Mobile Unit Kits

Includes four 74" high posts (1880mm) high mobile posts, four casters, donut bumpers, and other hardware to assemble a mobile unit. Shelves are sold separately. One kit required per mobile unit.

Super Erecta, Super Erecta Pro, Super Adjustable Super Erecta				MetroMax Q		MetroMax i	
Approx. Pkd. Wt. (lbs.)	Approx. Pkd. Wt. (kg)	Cat. No. Chrome-Plated	Cat. No. Metroseal 3 with Microban®	Cat. No. Stainless Steel	Approx. Pkd. Wt. (lbs.)	Approx. Pkd. Wt. (kg)	Cat. No.
25.0	11.4	<b>BTMC</b>	<b>BTMK3</b>	<b>BTMS</b>	27.0	12.3	<b>BTMQ3</b>
							18.5 8.4 <b>BTMX3</b>

Note: All casters feature an acetyl grooved wheel. Chrome plated kit (BTMC) includes casters with plated steel components. BTMK3/BTMS/BTMQ3/BTMX3 kits include casters with stainless steel components.

Track Sets

Includes tracks and hardware needed to assemble track runs up to 21' (6400mm).

Length (ft.)	Length (mm)	Approx. Pkd. Wt. (lbs.)	Approx. Pkd. Wt. (kg)	Cat. No.	Length (ft.)	Length (mm)	Approx. Pkd. Wt. (lbs.)	Approx. Pkd. Wt. (kg)	Cat. No.
2.5	762	4	1.8	<b>BTS2.5NA</b>	14	4267	19	8.6	<b>BTS14NA</b>
6	1828	9	4.1	<b>BTS6NA</b>	15	4572	21	9.5	<b>BTS15NA</b>
7	2135	10	4.5	<b>BTS7NA</b>	16	4877	22	10.0	<b>BTS16NA</b>
8	2440	11	5.0	<b>BTS8NA</b>	17	5182	23	10.5	<b>BTS17NA</b>
9	2743	13	5.9	<b>BTS9NA</b>	18	5486	25	11.4	<b>BTS18NA</b>
10	3048	14	6.4	<b>BTS10NA</b>	19	5791	26	11.8	<b>BTS19NA</b>
11	3352	15	6.8	<b>BTS11NA</b>	20	6096	27	12.3	<b>BTS20NA</b>
12	3657	17	7.7	<b>BTS12NA</b>	21	6400	29	13.2	<b>BTS21NA</b>
13	3962	18	8.2	<b>BTS13NA</b>					

Note: BTS2.5NA includes a joining kit to connect the tracks to other track sets.

✓ Indicates antimicrobial product.

Notes:

1. All end, intermediate, and mobile units must be 18" (457mm) or wider.
2. Each stationary end and intermediate unit must have a minimum of four shelves. Super Adjustable shelves may be used for all tiers.
3. qwikTRAK is available with 74" posts (1880mm) as standard. Requests for TALLER posts must be reviewed by Metro Engineering. For applications requiring posts SHORTER than 74" (1880mm), contact your Metro representative.
4. Existing Metro Super Erecta, Super Adjustable, MetroMax Q, and MetroMax i shelving units can be retrofitted as part of a HD qwikTRAK installation.
5. Under normal conditions, aisle width of 30"-36" (760-914mm) is recommended. The storage of very large objects within the system, however, may require an aisle width larger than 36" (914mm).
6. A stationary intermediate unit is required when the track length exceeds 21 feet (6400mm). A stationary intermediate unit may be used at the discretion of the user when the track lengths are less than 21 ft. (6400mm).
7. It is recommended that the tracks are installed a minimum of 1 3/4" (45mm) from the wall.
8. Actual width of a qwikTRAK system is the Nominal Shelf length + 3 1/2" (89mm).
9. Actual height of a mobile qwikTRAK unit is: Nominal post height + 4.5" (115mm)
10. Actual length of a qwikTRAK system is: Nominal track length + the nominal width of each end unit + 3" (76mm)
11. Weight capacities for standard qwikTRAK: Super Erecta, Super Adjustable, MetroMax Q systems are designed to hold up to 2,000 lbs. (907kg) per shelving unit. MetroMax i stationary units can hold up to 2,000 lbs. (907kg); MetroMax i mobile units can hold up to 1,200 lbs. (544kg) per unit.

Double-Deep qwikTRAK® Storage System for: Super Erecta, Super Erecta Pro, Super Adjustable, MetroMax Q, and MetroMax i Systems.

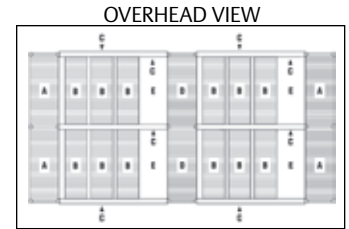
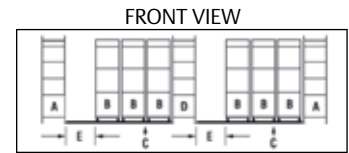

Shelves Sold Separately  
 Super Erecta — Pg. 42  
 Super Erecta Pro — Pg. 34  
 Super Adjustable — Pg. 37  
 MetroMax Q — Pg. 15  
 MetroMax i — Pg. 14

**SYSTEM COMPONENTS**  
 A = Stationary End Units  
 B = Mobile Units  
 C = qwikTRAK  
 D = Stationary Intermediate Unit  
 E = Active Aisle

## Donut

### Stationary End Unit Kits

Includes 74" high posts (1880mm) high stationary posts and hardware necessary for connecting stationary end units to tracks and anchoring tracks to the floor. Order one kit per double-deep system. Shelves are sold separately.

Super Erecta, Super Erecta Pro, Super Adjustable Super Erecta				MetroMax Q		MetroMax i				
Approx. Pkd. Wt. (lbs.)		Cat. No. Chrome-Plated	Cat. No. Metroseal 3 with Microban®	Cat. No. Stainless Steel	Approx. Pkd. Wt. (lbs.)		Cat. No.	Approx. Pkd. Wt. (kg)	Cat. No.	
73.6	33.5	<b>LBTEC</b>	<b>LBTEK3</b>	<b>LBTES</b>	76.3	34.7	<b>LBTEQ3</b>	42.3	19.2	<b>LBTEX3</b>

### Stationary Intermediate Unit Kits

Includes 74" high posts (1880mm) high stationary posts and hardware necessary for connecting one double-deep stationary intermediate unit to tracks and anchoring tracks to the floor. Shelves are sold separately.

Super Erecta, Super Erecta Pro, Super Adjustable Super Erecta				MetroMax Q		MetroMax i				
Approx. Pkd. Wt. (lbs.)		Cat. No. Chrome-Plated	Cat. No. Metroseal 3 with Microban®	Cat. No. Stainless Steel	Approx. Pkd. Wt. (lbs.)		Cat. No.	Approx. Pkd. Wt. (kg)	Cat. No.	
39.6	18.0	<b>LBTAC</b>	<b>LBTAK3</b>	<b>LBTAS</b>	41.3	18.8	<b>LBTAQ3</b>	24.3	11.0	<b>LBTAX3</b>

## Mobile Units

Includes (8) 74" (1880mm) high -UP posts, (4) V-groove casters, (1) stainless steel center channel caster assembly, donut bumpers, Tie Bar Brackets, and other hardware. Shelves are sold separately. One kit required per Double-Deep Mobile Unit.

Super Erecta, Super Erecta Pro, Super Adjustable Super Erecta				MetroMax Q		MetroMax i	
Shelf Width (in.)	(mm)	Cat. No. Chrome	Cat. No. Metroseal 3 with Microban®	Cat. No. Stainless Steel	Cat. No.	Cat. No.	Cat. No.
18	457	<b>LBTM18C</b>	<b>LBTM18K3</b>	<b>LBTM18S</b>	<b>LBTM18Q3</b>		<b>LBTM18X3</b>
21	530	<b>LBTM21C</b>	<b>LBTM21K3</b>	<b>LBTM21S</b>	<b>LBTM21Q3</b>		—
24	610	<b>LBTM24C</b>	<b>LBTM24K3</b>	<b>LBTM24S</b>	<b>LBTM24Q3</b>		<b>LBTM24X3</b>

**Note:** All casters feature an acetyl grooved wheel. Chrome plated kit includes single casters with plated steel components. Metroseal 3/Stainless Steel/MetroMax Q/MetroMax i kits include single casters with stainless steel components.

## Track Sets

Includes tracks and hardware needed to assemble Double-Deep qwikTRAK systems up to 21' (6400mm).

Length (ft.)	(mm)	Approx. Pkd. Wt. (lbs.)	(kg)	Cat. No.	Length (ft.)	(mm)	Approx. Pkd. Wt. (lbs.)	(kg)	Cat. No.
2.5	762	4	1.8	<b>LBTS2.5NA</b>	14	4267	19	8.6	<b>LBTS14NA</b>
6	1828	9	4.1	<b>LBTS6NA</b>	15	4572	21	9.5	<b>LBTS15NA</b>
7	2135	10	4.5	<b>LBTS7NA</b>	16	4877	22	10.0	<b>LBTS16NA</b>
8	2440	11	5.0	<b>LBTS8NA</b>	17	5182	23	10.5	<b>LBTS17NA</b>
9	2743	13	5.9	<b>LBTS9NA</b>	18	5486	25	11.4	<b>LBTS18NA</b>
10	3048	14	6.4	<b>LBTS10NA</b>	19	5791	26	11.8	<b>LBTS19NA</b>
11	3352	15	6.8	<b>LBTS11NA</b>	20	6096	27	12.3	<b>LBTS20NA</b>
12	3657	17	7.7	<b>LBTS12NA</b>	21	6400	29	13.2	<b>LBTS21NA</b>
13	3962	18	8.2	<b>LBTS13NA</b>					

**Note:** LBTS2.5NA includes a joining kit to connect the track to other track sets.

✓ Indicates antimicrobial product.

### Notes:

- All end, intermediate, and mobile units must be 18" (457mm) or wider.
- Each stationary end and intermediate unit must have a minimum of four shelves. Top and bottom Super Erecta shelves are required on all units with Super Adjustable shelves.
- For applications with Super Adjustable wire shelves, the top and bottom shelf of every double deep mobile unit MUST be standard Super Erecta wire shelves.
- quwikTRAK is available with 74" posts (1880mm) as standard. Requests for TALLER posts must be reviewed by Metro Engineering. For applications requiring posts SHORTER than 74" (1880mm), contact your Metro representative.
- Under normal conditions, aisle width of 30"-36" (760-914mm) is recommended. The storage of very large objects within the system, however, may require an aisle width larger than 36" (914mm).
- Two stationary intermediate units connected end to end are required when the track length exceeds 21 feet (6400mm). Stationary intermediate units may be used at the discretion of the user when the track lengths are less than 21 ft. (6400mm).
- It is recommended that the tracks are installed a minimum of 1 3/4" (45mm) from the wall.
- Maximum allowable shelf length for use with a double deep system is 60" (1524mm).
- The maximum width of a double deep configuration is 10'6" (3200mm). (i.e., two systems, each having 60" (1524mm) long shelves, plus 6" (150mm) for qwikTRAK components.
- Actual width of a double deep configuration is the Nominal Shelf Length + 3 1/2" (89mm).
- Weight capacities: Double Deep Mobile Units — Super Erecta/Super Adjustable, Super Erecta/MetroMax Q: 3,000 lbs. (1364kg) evenly distributed. MetroMax i: 1,800 lbs. (818kg) evenly distributed. Stationary End and Intermediate Units — Each end and intermediate double deep unit consists of two independent stationary shelving units positioned side by side. Each shelving unit has a maximum weight capacity of 2,000 lbs. (907kg).



Wire Shelving — Super Erecta®, Super Erecta Pro™ and Super Adjustable Top-Track — 11.12



Super Erecta® Top-Track®

FRONT VIEW

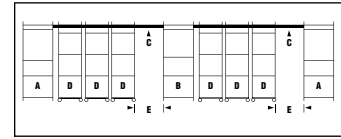

A = Stationary End Units  
 B = Stationary Intermediate Unit (Optional)  
 C = Track Set  
 D = Mobile Units  
 E = Open Aisle

OVERHEAD VIEW

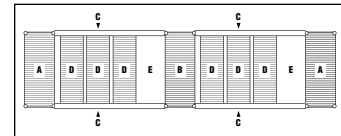

**Stationary End Unit Kits**

Includes hardware necessary for connecting stationary end units to track. One kit is required per single system. 86" (2185mm) posts are included. Shelves sold separately — See pages 34, 37 and 42.

Shelf Width (in.) (mm)	Approx. Pkd. Wt. (lbs.) (kg)	Cat. No. Chrome-Plated	Cat. No. Metroseal 3 with Microban®	Cat. No. Stainless Steel
18 457	11 4.9	TTE18C	TTE18K3	TTE18S
21 530	11.5 5.1	TTE21C	TTE21K3	TTE21S
24 610	12 5.4	TTE24C	TTE24K3	TTE24S



**Stationary Intermediate Unit Kits**

Includes hardware necessary for connecting intermediate unit to track on both sides. 86" (2185mm) posts are included. Shelves sold separately — See pages 34, 37 and 42.

Shelf Width (in.) (mm)	Approx. Pkd. Wt. (lbs.) (kg)	Cat. No. Chrome-Plated	Cat. No. Metroseal 3 with Microban®	Cat. No. Stainless Steel
18 457	7.5 3.3	TTA18C	TTA18K3	TTA18S
21 530	8 3.6	TTA21C	TTA21K3	TTA21S
24 610	8.5 3.8	TTA24C	TTA24K3	TTA24S

Refer to pages 55-62 for a complete selection of Super Erecta Shelf accessories. For Top-Track accessories, see page 100.

**Track Sets**

Includes necessary sections of track for assembling track runs up to 21' (6400mm).

Length (feet) (mm)	Approx. Pkd. Wt. (lbs.) (kg)	Cat. No.	Length (feet) (mm)	Approx. Pkd. Wt. (lbs.) (kg)	Cat. No.
2½ 762	15 6.8	TTS2.5NA	14 4267	98 44.1	TTS14NA
6 1828	40.5 18.2	TTS6NA	15 4572	106.5 47.9	TTS15NA
7 2135	47.5 21.3	TTS7NA	16 4877	113.5 51	TTS16NA
8 2440	56 25.2	TTS8NA	17 5182	121 54.4	TTS17NA
9 2743	62.5 28.1	TTS9NA	18 5486	128 51.6	TTS18NA
10 3048	69.5 31.2	TTS10NA	19 5791	135 60.7	TTS19NA
11 3353	76.5 34.4	TTS11NA	20 6096	142 63.9	TTS20NA
12 3657	83.5 37.5	TTS12NA	21 6400	149 67	TTS21NA
13 3962	92 41.4	TTS13NA			

Note: TTS2.5NA includes a joining kit to connect the track to other track sets.

**Notes:**

- Each stationary end and intermediate unit must have a minimum of four shelves. For all Super Adjustable applications, the top and bottom shelves must be round collar Super Erecta shelves.
- The standard Deep Top-Track system requires the use of 86" (2185mm) posts (i.e., 86P, 86PK3, or 86PS) on the stationary end and intermediate units. Shelves for the stationary end and intermediate units are sold separately.
- The mobile unit kit includes special 74" (1880mm) posts with casters. Shelves for mobile units are sold separately.
- Mobile units: If 18" wide mobile units are planned, the maximum allowable length shelf is 60" (1524mm) long. If 18" (457mm) wide by 60" (1524mm) long mobile units are planned, a maximum of five 18" (457mm) mobile units are allowable between two stationary units. 18" (457mm), 21" (530mm), 24" (610mm) wide mobile units can be intermixed in a given system. Recommended maximum load rating for a mobile unit is 900 lbs. (410kg). Floor should be level, smooth, and free from large cracks and raised obstacles.
- Under normal conditions, an aisle width of 30"-36" (760-914mm) is recommended. The storage of very large objects within the system, however, may require an aisle width larger than 36" (914mm).
- A stationary intermediate unit is required when track length exceeds 21 feet (6400mm). A stationary intermediate unit may be used at the discretion of the user when track lengths are less than 21 feet (6400mm).
- To accommodate bumpers, the actual size of a mobile unit is 2.5" (63.5mm) wider than the shelf width shown. For example, an 18" (457mm) wide unit is actually 20.5" (52mm).
- To calculate the overall length of a Super Erecta Top Track System, add the following: Nominal track length + Nominal widths of each end unit + 1.5" (38mm).

**Mobile Unit Kits** (shelves sold separately — see pages 34, 37 and 42)

One kit required per mobile unit. Kit includes posts, casters/caster channels, donut bumpers, and roller bearing assemblies.

Shelf Width (in.) (mm)	Overall Width (in.) (mm)	Approx. Pkd. Wt. (lbs.) (kg)	Cat. No. Chrome-Plated	Cat. No. Metroseal 3 with Microban®	Cat. No. Stainless Steel
18 457	20¼ 514	32 14.4	TTM18C	TTM18K3	TTM18S
21 530	23¼ 590	33 14.8	TTM21C	TTM21K3	TTM21S
24 610	26¼ 667	34 15.3	TTM24C	TTM24K3	TTM24S

Note: Casters feature wheels with polyurethane tread. Chrome plated kits include casters with plated steel components. Metroseal 3 and Stainless Steel kits include casters with stainless steel components.

✓ Indicates antimicrobial product.

Super Erecta® and Super Adjustable Double-Deep Top-Track® — 11.12

**Stationary End Unit Kits**

Includes hardware necessary for connecting stationary end units in Double Deep systems and connecting to an overhead track set. One kit is required for the entire double deep configuration. Shelves sold separately — See pages 37 and 42. 86" (2185mm) posts included.

Shelf Width (in.)	(mm)	Approx. Pkd. Wt.		Cat. No. Chrome-Plated
		(lbs.)	(kg)	
18	457	33	14.8	<b>LTTE18C</b>
21	530	37	16.6	<b>LTTE21C</b>
24	610	41	18.4	<b>LTTE24C</b>

**Stationary Intermediate Unit Kits**

Includes hardware necessary for connecting intermediate units in Double Deep systems and connecting to an overhead track set on each side. One kit is required for Intermediate units connected end-to-end. Shelves sold separately — See pages 37 and 42. 86" (2185mm) posts included.

Shelf Width (in.)	(mm)	Approx. Pkd. Wt.		Cat. No. Chrome-Plated
		(lbs.)	(kg)	
18	457	18	8	<b>LTTA18C</b>
21	530	20	9	<b>LTTA21C</b>
24	610	22	9.9	<b>LTTA24C</b>

**Track Sets**

Includes necessary sections of track for assembling track runs up to 21' (6400mm). For track sizes within the even 1-foot (305mm) increments, contact your Metro representative. Only one track set is required between stationary units.

Length (feet)	(mm)	Approx. Pkd. Wt.		Cat. No.
		(lbs.)	(kg)	
2½	762	15	6.8	<b>TTS2.5NA</b>
6	1828	40.5	18.2	<b>TTS6NA</b>
7	2135	47.5	21.3	<b>TTS7NA</b>
8	2440	56	25.2	<b>TTS8NA</b>
9	2743	62.5	28.1	<b>TTS9NA</b>
10	3048	69.5	31.2	<b>TTS10NA</b>
11	3353	76.5	34.4	<b>TTS11NA</b>
12	3657	83.5	37.5	<b>TTS12NA</b>
13	3962	92	41.4	<b>TTS13NA</b>

Length (feet)	(mm)	Approx. Pkd. Wt.		Cat. No.
		(lbs.)	(kg)	
14	4267	98	44.1	<b>TTS14NA</b>
15	4572	106.5	47.9	<b>TTS15NA</b>
16	4877	113.5	51	<b>TTS16NA</b>
17	5182	121	54.4	<b>TTS17NA</b>
18	5486	128	51.6	<b>TTS18NA</b>
19	5791	135	60.7	<b>TTS19NA</b>
20	6096	142	63.9	<b>TTS20NA</b>
21	6400	149	67	<b>TTS21NA</b>

**Note:** TTS2.5NA includes a joining kit to connect the track to other track sets.

**Mobile Unit Kits**

Includes posts, casters, caster channels, donut bumpers, roller bearing assemblies, and tie-together hardware to connect two mobile units (i.e., one in each system). Shelves sold separately — See pages 37 and 42.

Shelf Width (in.)	(mm)	Overall Width		Approx. Pkd. Wt.		Cat. No. Chrome-Plated
		(in.)	(mm)	(lbs.)	(kg)	
18	457	20¼	514	72	32.4	<b>LTTM18C</b>
21	530	23¼	590	75	33.7	<b>LTTM21C</b>
24	610	26¼	667	78	35	<b>LTTM24C</b>

**Notes:**

- Each stationary end and intermediate unit **must** have a minimum of four shelves. For all Super Adjustable applications, the top and bottom shelves must be non "quick adjust" Super Erecta shelves.
- The standard Double Deep Top-Track system requires the use of 86" (2185mm) posts (i.e., 86P) on the stationary end and intermediate units. **Shelves for the stationary end and intermediate units are sold separately.**
- The mobile unit kits include special 74" (1880mm) posts with casters. **Shelves for mobile units are sold separately.**
- Under normal conditions, an aisle width of 30"-36" (760-914mm) is recommended. The storage of very large objects within the system, however, may require an aisle width larger than 36" (914mm).
- Two intermediate shelving units connected end-to-end are required when the track length exceeds 21 feet (6400mm). Stationary intermediate shelving units may be used at the discretion of the user when track lengths are less than 21 feet (6400mm).
- The maximum Double Deep system configuration is 10'6" (3200mm) (i.e., two systems, each having 60" (1524mm) long shelves, plus 6" (150mm) for Top-Track components).
- Ease of rollability for the mobile units is an important consideration in evaluating Top-Track as a possible storage alternative. The floor should be level, smooth, and free from large cracks and raised obstacles. Two mobile shelving units connected end-to-end and loaded with between 800 to 1,200 lbs. (365-550kg) will require a human effort range (in lbs. of human force) of between 18-24 lbs. (8-11kg) to move the unit from a complete stop. Subjectively, an average 110 lb. (50kg) person will perceive this as acceptable effort levels. For loads over 1,200 lbs. (550kg), contact your Metro representative.
- Mobile units should have the top shelf positioned as close as possible to the track.
- To accommodate bumpers, the actual size of a mobile unit is 2.5" (63.5mm) wider than the shelf width shown. For example, an 18" (457mm) wide unit is actually 20.5" (52mm).
- To calculate the overall length of a Super Erecta Top Track System, add the following: Nominal track length + Nominal widths of each end unit + 1.5" (38mm).

FRONT VIEW

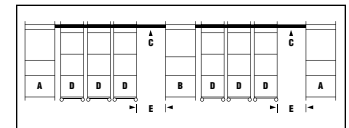

- A = Stationary End Units
- B = Stationary Intermediate Unit (Optional)
- C = Track Set
- D = Mobile Units
- E = Open Aisle

OVERHEAD VIEW

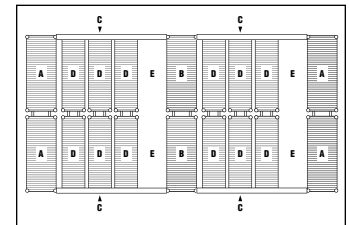

For Top-Track accessories, see page 100.

### Seismic Top-Track® Single Length System

**End Unit Kit:**

Includes four shelves, four staked posts, bracket bars, sway braces (for top, back, and end), anchor plates, foot plates, tubular braces, clamps, and assembly hardware.

Description	Cat. No.
Kit for 48" (1219mm) Stationary End Unit	SA48TTS
Kit for 54" (1370mm) Stationary End Unit	SA54TTS
Kit for 60" (1524mm) Stationary End Unit	SA60TTS

**Strut Kit:**

Description	Cat. No.
Kit for 48" (1219mm) Wide Unit	TTB48STRUT
Kit for 54" (1370mm) Wide Unit	TTB54STRUT
Kit for 60" (1524mm) Wide Unit	TTB60STRUT

**Note:** Floor anchoring hardware not included.

Example: For a complete "Single-Length Top-Track® System," the following would be required: Two Stationary End Units, One Track Set\* (11-foot [3355mm] maximum), One Center Strut (if track length exceeds 7 feet), Mobile Units.

Note: Posts and shelves are included in the end and intermediate unit kits. Shelves are sold separately for the mobile unit.

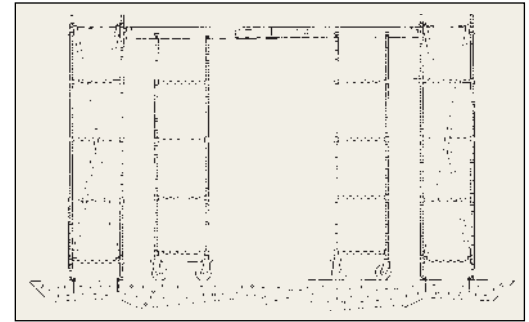

Single-Length System

Add track sets and mobile unit kits, refer to page 96.

### Seismic Top-Track® Double Length System

**End Unit Kit:**

Includes four shelves, four staked posts, bracket bars, sway braces (for top, back, and end), anchor plates, foot plates, tubular braces, clamps, and assembly hardware.

Description	Cat. No.
Kit for 48" (1219mm) Stationary End Unit	SA48TTS
Kit for 54" (1370mm) Stationary End Unit	SA54TTS
Kit for 60" (1524mm) Stationary End Unit	SA60TTS

**Intermediate Unit Kit:**

Includes eight shelves, eight staked posts, bracket bars, sway braces (for top, back, and end), anchor plates, foot plates, tubular braces, clamps, and assembly hardware.

Description	Cat. No.
Kit for 48" (1219mm) Stationary Intermediate Unit	SA48TTIS
Kit for 54" (1370mm) Stationary Intermediate Unit	SA54TTIS
Kit for 60" (1524mm) Stationary Intermediate Unit	SA60TTIS

**Strut Kit:**

Description	Cat. No.
Kit for 48" (1219mm) Wide Unit	TTB48STRUT
Kit for 54" (1370mm) Wide Unit	TTB54STRUT
Kit for 60" (1524mm) Wide Unit	TTB60STRUT

**Note:** Floor anchoring hardware not included.

Example: For a complete "Double-Length Top-Track® System," the following would be required: Two Stationary End Units, Two Track Sets\* (11-foot [3355mm] maximum), One Intermediate Unit, Two Center Struts (if track length exceeds 7 feet [2135mm]), Mobile Units.\*

Note: Posts and shelves are included in the end and intermediate unit kits. Shelves are sold separately for the mobile unit.

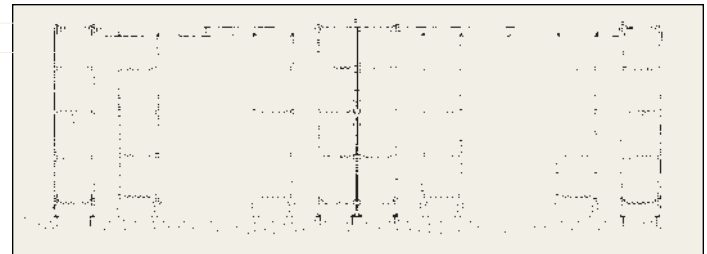

Double-Length System

Add track sets and mobile unit kits, refer to page 96.

See page 108-109 for Stationary Seismic shelving.

**Notes:**

- Each installation must have two stationary end units for a single-track length of 7' (2135mm) to 11' (3355mm).
- A center strut is required for each track section over 7' (2135mm).
- For track lengths over 11' (3355mm), an intermediate unit is required, thus creating a double-length system.
- Seismic Top-Track is based upon a weight-loading capacity of 25 lbs. (11kg) per square foot on a four-shelf stationary and mobile units, with maximum of 900 lbs. (408kg) per mobile unit. Additional shelves may be added, but are limited to a maximum load of 25 lbs. (11kg) per cubic foot per unit.
- A maximum of four 21" (6400mm) or 24" (610mm), or five 18" (457mm) mobile units are allowed per an 11' (3355mm) track length, with no more than a 900 lb. (408kg) weight capacity per mobile unit.
- Stationary End Units are available in 24"x48" (610x1219mm), 24"x54" (610x1370mm), and 24"x60" (610x1524mm).
- Seismic Top-Track design is based on the use of HR concrete, at least 5 1/2" (140mm) thick, with a compressive strength of 3,000 psi (211kg/cm). Anchorage is not included.
- To calculate the overall length of a Super Erecta Top Track System, add the following: Nominal track length + Nominal widths of each end unit + 1.5" (38mm).

**Notes:**

- Floor anchors are not included. The structural engineer of record must verify that the anchorage bolt and building structure are adequate for the applied load.
- For Seismic Top-Track, the highest load shelf must be no more than 60" (1524mm) from the floor.
- For Seismic Top-Track, a unit must have no more than four loaded shelves within 60" (1524mm) height.
- If a fifth shelf is used, it must serve only as a cover and not be used for load bearing.
- Each shelving unit, whether single or "back-to-back" cannot connect to other shelving units or walls.



# METROMAX i® AND METROMAX Q® TOP-TRACK®



## MetroMax iQ™ Top-Track — 9.29

The system compensates for uneven floor surfaces. Floor should be smooth and free from large cracks or raised obstacles. Maximum load capacity for mobile units is 900 lbs. (400kg).

**Maximizes Storage Capacity:** Top-Track can increase the storage capacity of a given area by 30% to 40%. Put more storage units into a defined space. A movable, open aisle allows full access to each entire shelving unit — eliminating hard to reach or “dead” spaces.

**Easy Access:** The overhead track system guides the mobile units and opens an access aisle between any two units. The track is above the storage units enabling easy access.

**Clean Design:** Guide tracks are installed overhead enabling easy cleaning of floors. MetroMax i® and MetroMax Q shelves feature removable polymer shelf mats and built-in Microban antimicrobial product protection to promote easier routine cleaning.

**Uniquely Interchangeable:** Mix and match MetroMax i® and Q shelves and posts based on the application. Corrosion proof MetroMax i® offers solid shelf option and better chemical resistance. Corrosion resistant MetroMax Q steel posts can improve the overall rigidity of the Top-Track system in higher weight bearing applications.

### Stationary End Unit Kit — Order one per Top-Track system.

- Includes hardware and components to connect track sets to two stationary end units. 86" (2185mm) posts included. Shelves are ordered separately (see pages 14 and 15).

Fits Shelf Width (in.)	Fits Shelf Width (mm)	i	Q
		Cat. No. End Unit Kit	Cat. No. End Unit Kit
18	457	<b>MXTTE18</b>	<b>MQTTE18</b>
21	530	—	<b>MQTTE21</b>
24	610	<b>MXTTE24</b>	<b>MQTTE24</b>

### Stationary Intermediate Unit Kit —

Required when the desired length of track exceeds 21' (6405mm).

- A stationary intermediate kit may be used at the discretion of the end user when track lengths are less than 21' (6405mm) to increase the overall rigidity of the system. Kit includes the hardware and components needed to connect track sets to one stationary intermediate unit. 86" (2185mm) posts included. Shelves are ordered separately (see pages 14 and 15).

Fits Shelf Width (in.)	Fits Shelf Width (mm)	i	Q
		Cat. No. Intermediate Unit Kit	Cat. No. Intermediate Unit Kit
18	457	<b>MXTTA18</b>	<b>MQTTA18</b>
21	530	—	<b>MQTTA21</b>
24	610	<b>MXTTA24</b>	<b>MQTTA24</b>

### Mobile Unit Kit — Order one per mobile unit.

- Kit includes posts, rigid casters, caster channels, bumpers, and roller assemblies. Shelves are sold separately.

Fits Shelf Width (in.)	Fits Shelf Width (mm)	i	i	Q	Q
		Cat. No. with Plated Casters	Cat. No. with Stainless Casters	Cat. No. with Plated Casters	Cat. No. with Stainless Casters
18	457	<b>MXTTM18C</b>	<b>MXTTM18S</b>	<b>MQTTM18C</b>	<b>MQTTM18S</b>
21	530	—	—	<b>MQTTM21C</b>	<b>MQTTM21S</b>
24	610	<b>MXTTM24C</b>	<b>MXTTM24S</b>	<b>MQTTM24C</b>	<b>MQTTM24S</b>

### Track Sets — One track set is required between stationary units

- Includes necessary sections of track for assembling track runs of 6' to 21' (1830-6405mm).

Length (feet)	Length (mm)	Approx. Pkd. Wt.		Cat. No.	Length (feet)	Length (mm)	Approx. Pkd. Wt.		Cat. No.
		(lbs.)	(kg)				(lbs.)	(kg)	
2½	762	15	6.8	<b>TTS2.5NA</b>	14	4267	98	44.1	<b>TTS14NA</b>
6	1828	40.5	18.2	<b>TTS6NA</b>	15	4572	106.5	47.9	<b>TTS15NA</b>
7	2135	47.5	21.3	<b>TTS7NA</b>	16	4877	113.5	51	<b>TTS16NA</b>
8	2440	56	25.2	<b>TTS8NA</b>	17	5182	121	54.4	<b>TTS17NA</b>
9	2743	62.5	28.1	<b>TTS9NA</b>	18	5486	128	51.6	<b>TTS18NA</b>
10	3048	69.5	31.2	<b>TTS10NA</b>	19	5791	135	60.7	<b>TTS19NA</b>
11	3353	76.5	34.4	<b>TTS11NA</b>	20	6096	142	63.9	<b>TTS20NA</b>
12	3657	83.5	37.5	<b>TTS12NA</b>	21	6400	149	67	<b>TTS21NA</b>
13	3962	92	41.4	<b>TTS13NA</b>					

**Note:** TTS2.5NA includes a joining kit to connect the tracks to longer track sections.

### Configuration Guidelines

- Standard Top-Track models include 86" (2185mm) stationary posts and 74" (1880mm) stem caster mobile posts. If a taller system is required, consult Metro Engineering.
- Mobile, stationary end, and intermediate units must have a minimum of 4 shelves.
- Stationary Intermediate Unit is required when the track length exceeds 21' (6405mm). Intermediate kits include special support rails that attach to the overhead tracks on both sides of the intermediate unit. A stationary intermediate unit may be used at the discretion of the user when track lengths are less than 21' (6405mm) for the purpose of adding greater stability to the overall system.
- Mobile Units: If 18" (457mm) wide mobile units are planned, the maximum allowable size shelf is 60" (1524mm) long. If 18" (457mm) wide by 60" (1524mm) long mobile units are planned, a maximum of five 18" (457mm) mobile units are allowable between two stationary units. 18" (457mm), 21" (530mm) and 24" (610mm) wide mobile units can be intermixed in a given system. The standard system requires 74" (1880mm) posts on the mobile units. Recommended maximum load rating for a mobile unit is 900 lbs. (410kg).
- Under normal conditions, an aisle of 30" to 36" (760-914mm) is recommended. The storage of very large objects within the system, however, may require an aisle width larger than 36" (914mm).
- To accommodate bumpers, the actual size of a mobile unit is 2.5" (63.5mm) wider than the shelf width shown. For example, an 18" (457mm) wide unit is actually 20.5" (521mm).
- To calculate the overall length of a MetroMax i or MetroMax Q Top-Track System, add the following: Nominal track length + Nominal widths of each end unit + 2" (51mm).

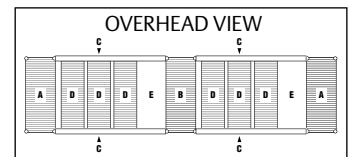
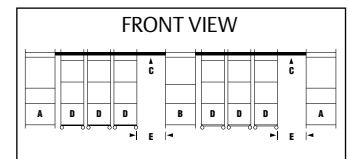

- A = Stationary End Units
- B = Stationary Intermediate Unit (Optional)
- C = Track Set
- D = Mobile Units
- E = Open Aisle

**Top-Track® Floor Pad Protectors — 9.29 11.12**

Use for both MetroMax Top-Track and Super Erecta Top-Track Systems.

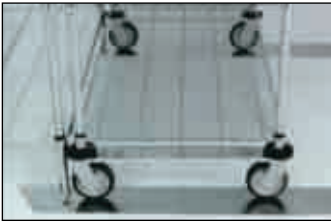

Top-Track® Floor Protectors

For Track Length (ft.) (mm)		Cat. No.	For Track Length (ft.) (mm)		Cat. No.
6	1828	<b>FPS6N</b>	14	4267	<b>FPS14N</b>
7	2135	<b>FPS7N</b>	15	4572	<b>FPS15N</b>
8	2440	<b>FPS8N</b>	16	4877	<b>FPS16N</b>
9	2743	<b>FPS9N</b>	17	5182	<b>FPS17N</b>
10	3048	<b>FPS10N</b>	18	5486	<b>FPS18N</b>
11	3353	<b>FPS11N</b>	19	5791	<b>FPS19N</b>
12	3657	<b>FPS12N</b>	20	6096	<b>FPS20N</b>
13	3962	<b>FPS13N</b>	21	6400	<b>FPS21N</b>



Top-Track® Wall Mount Bracket

**Top-Track® Wall Mount Bracket — 11.12**

Used to attach one set of tracks to the wall. Eliminates the need for a stationary end unit. Includes one pair of wall brackets and hardware to attach tracks to the wall brackets. Hardware to attach the wall brackets to the wall is NOT included.

Cat. No. **TTWM**



Top-Track® Stop Plate Kit

**Top-Track® Stop Plate Kit — 11.12**

Used in conjunction with the Wall Mount Bracket Kit. The stop plates bolt to the underside of the track next to the wall brackets to prevent the mobile units from bumping into the wall.

Cat. No. **TTSTP**

**Metro Tip:**

Floor pad protectors compensate for soft flooring materials by protecting the floor from wear and tear. For new construction projects, it is recommended that flooring of suitable durability is used in areas where Top-Track will be installed.



qwikTRAK Stop Plate Kit

**qwikTRAK Stop Plate Kit**

Eliminates the need for a stationary end unit. The kit contains two “L-shaped” stop plates that mount to the ends of the floor tracks. The stop plates prevent a mobile unit from rolling off the end of the tracks.

Cat. No. **BTSP**

Consult your Metro representative for guidance on configuring a qwikTRAK system using this kit.

Stop plates (kit of two) shown mounted to the end plates on the floor tracks.

**Super Erecta® Hi-Rise Shelving — 10.17**

- For light-duty storage applications where floor space is at a premium.
- Construct shelving up to 24 feet (7315mm) high — 3 times the height of conventional shelving
- Metro’s computerized engineering system assures correct specifications and load rating of Hi-Rise materials for your application.

All Hi-Rise installations must be reviewed and approved by Metro Engineering. Hi-Rise certification plate supplied. Only Super Erecta and Super Adjustable Super Erecta wire shelves (found on pages 37 and 42) can be used in Hi-Rise applications. Contact Metro customer service or your local Metro representative for details.

Material part numbers will be provided by Metro Product Development upon review of application.

**Metro Tip:**

One frequently overlooked opportunity to gain additional storage capacity is the efficient use of vertical space. By connecting Super Erecta posts, storage areas may be created that utilize every available cubic foot of unused vertical air space.



Super Erecta Hi-Rise Shelving

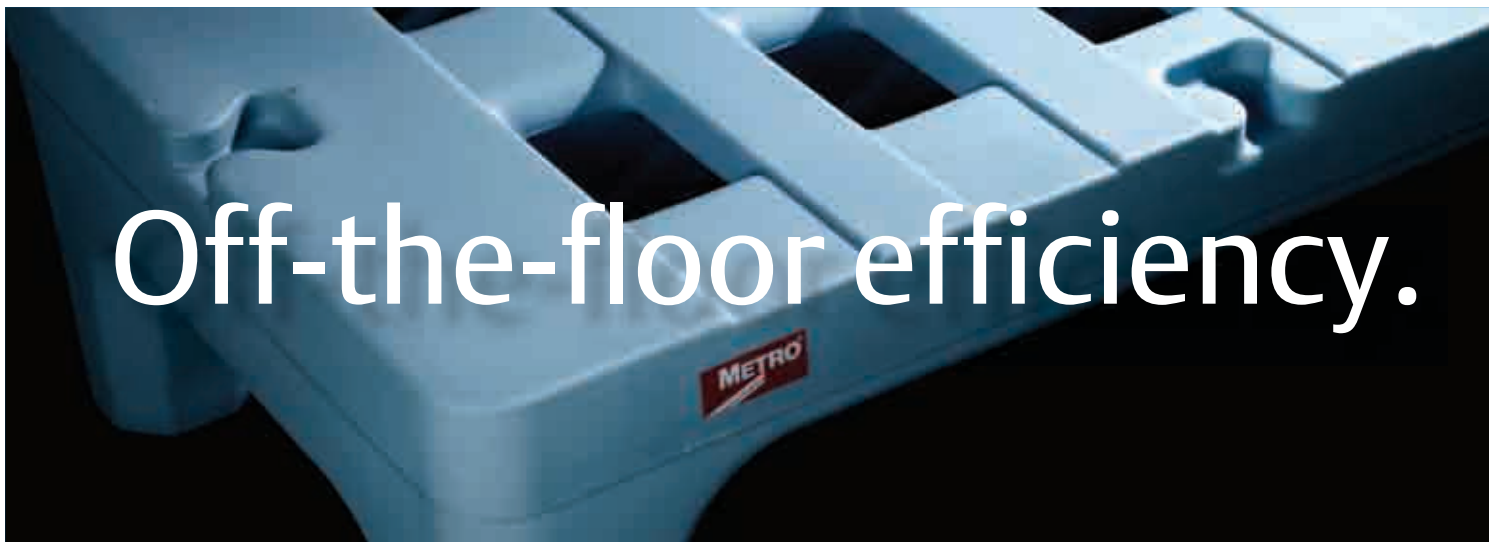

**Bow-Tie™ Dunnage Racks — 9.09**

12" (305mm) high; 22" (559mm) wide.

- Metro Bow-Tie Dunnage Racks are available with built-in Microban® antimicrobial product protection to protect from bacteria, mold, mildew and fungi that cause odors, stains and product degradation. Standard models, without Microban, are also available.
- Rust and corrosion-proof polymer material.
- Helps protect floors: legs have a larger radius than traditional dunnage racks and distribute the storage load across a wider area.
- Racks join together easily without tools in “end-to-end” and “back-to-back” configurations with the exclusive Bow-Tie™ feature.
- Heavy-duty construction gives racks the strength to hold up to 1,500 lbs. (683kg) for 30" (760mm) and 36" (914mm) long racks, and 3,000 (1365kg) for 48" (1219mm) and 60" (1524mm) racks.



Microban®  
antimicrobial product protection

Bow-Tie Dunnage Rack



Standard racks joined in “end-to-end” configuration.

Length (in.) (mm)	Height (in.) (mm)	Approx. Pkd. Wt. (lbs.) (kg)	Capacity (lbs.) (kg)	Cat. No.	
				Microban®	Standard
30	760	12 305	24 10.8	1500 68	HP2230PDMB HP2230PD
36	914	12 305	26 11.7	1500 68	HP2236PDMB HP2236PD
48	1219	12 305	34 15.3	3000 136	HP2248PDMB HP2248PD
60	1524	12 305	42 19	3000 136	HP2260PDMB HP2260PD

Indicates antimicrobial product.

Dunnage Platforms (Standard Duty) — 10.44

Space-saving platforms let you keep bulky items off the floor.

- Open wire provides air circulation and minimizes dust.
- All platforms use 13P or 13PS posts — height 14<sup>5</sup>/<sub>8</sub>" (371mm) including cap and leveling bolt.



Super Erecta Platform

Width/Length (in./mm)		Approx. Pkd. Wt. (lbs./kg)		Cat. No. Super Erecta Brite	Cat. No. Chrome	Cat. No. Stainless
18x24	457x610	11	5.0	P1824BR	P1824NC	P1824NS
18x30	457x760	12	5.5	P1830BR	P1830NC	P1830NS
18x36	457x914	13 <sup>1</sup> / <sub>2</sub>	6.1	P1836BR	P1836NC	P1836NS
21x24	530x610	12	5.5	P2124BR	P2124NC	P2124NS
21x30	530x760	13	5.9	P2130BR	P2130NC	P2130NS
21x36	530x914	15	6.8	P2136BR	P2136NC	P2136NS
24x24	610x610	13	5.9	P2424BR	P2424NC	P2424NS
24x30	610x760	15	6.8	P2430BR	P2430NC	P2430NS
24x36	610x914	17	7.7	P2436BR	P2436NC	P2436NS

Heavy-Duty Dunnage Racks — 10.46

A space-efficient way to store large, bulky items off the floor.

- Removable top mat lifts off for cleaning.
- Dunnage racks are 14<sup>1</sup>/<sub>2</sub>" (368mm) high including mat, cap and leveling bolt.



Dunnage Rack with Mat

Width/Length (in./mm)		Approx. Pkd. Wt. (lbs./kg)		Cat. No. Chrome	Cat. No. Metroseal 3 with Microban®	Cat. No. Stainless
18x24	457x610	22	10	HP31C	HP31K3	
18x30	457x760	25	11	HP32C	HP32K3	
18x36	457x914	30	13	HP33C	HP33K3	HP33S
18x48	457x1219	38	17	HP35C*	HP35K3*	HP35S*
24x24	610x610	28	12	HP51C	HP51K3	
24x30	610x760	30	14	HP52C	HP52K3	
24x36	610x914	36	16	HP53C	HP53K3	HP53S
24x48	610x1219	42	19	HP55C*	HP55K3*	HP55S*

Note: Maximum distributed static load capacity for stationary dunnage racks is 1,600 lbs. (725kg), except on units marked \* which have a 1,300 lb. (590kg) capacity.

Mobile Dunnage Racks (Heavy Duty) — 10.46

These easy-to-manuever racks feature two swivel and two swivel/brake casters; with non-marking polyurethane tread.

- Support frames: 1" (25mm) square tubing.
- Removable wire mat: 5<sup>1</sup>/<sub>16</sub>" (7.9mm) diameter wire.



Mobile Dunnage Rack shown in Metroseal 3 finish

Width/Length (in./mm)		Approx. Pkd. Wt. (lbs./kg)		Cat. No. Chrome	Cat. No. Metroseal 3 with Microban®	Cat. No. Stainless
18x36	457x914	42	18.9	MHP33C	MHP33K3	MHP33S
18x48	457x1219	50	22.5	MHP35C	MHP35K3	MHP35S
24x36	610x914	48	21.6	MHP53C	MHP53K3	MHP53S
24x48	610x1219	54	24.3	MHP55C	MHP55K3	MHP55S

Maximum distributed static load capacity is 800 lbs. (363kg).

Note: These units are designed for only the 5HP and 5HPB casters, which are shipped assembled with the special posts.

HD Super Duty Dunnage Racks — 10.68

Stores more than a ton safely off the floor.

- 48" (1219mm) rack has a 3,000 pound (1361kg) static load capacity (uniformly distributed); 60" (1524mm) rack carries up to 2,400 pounds (1089kg).
- HD Super™ design features fast, secure assembly without tools.
- Posts of 1<sup>5</sup>/<sub>8</sub>" (41mm) diameter provide greater rigidity.
- HD Super™ Dunnage Racks are 16<sup>1</sup>/<sub>4</sub>" (413mm) high including cap and leveling bolt.



HD Super Dunnage Rack

Width/Length (in./mm)		Approx. Pkd. Wt. (lbs./kg)		Cat. No. Chrome	Cat. No. Metroseal 3 with Microban®	Cat. No. Stainless
18x48	457x1219	52	23.4	HDP35C	HDP35K3	HDP35S
18x60	457x1524	62	27.9	HDP36C	HDP36K3	HDP36S
24x48	610x1219	57	26.6	HDP55C	HDP55K3	HDP55S
24x60	610x1524	66	29.7	HDP56C	HDP56K3	HDP56S

Maximum capacity 2,400 pounds (1089kg) uniformly distributed static load on the 60" (1524mm) length racks; 3,000 pounds (1361kg) on the 48" (1219mm) length racks.

Note: Capacity will be reduced and the unit will become less stable if the 3-sided frame is mounted higher than 6" (152mm) from the floor.



Indicates antimicrobial product.



## Security Units

Protect valuable materials and sensitive items from loss or pilferage.

- Ready View of Contents: Heavy-gauge open wire construction keeps contents visible at all times, making it easy to check inventory.
- Optional Adjustable Intermediate Shelves: Patented easily adjustable shelf designs — Super Adjustable Super Erecta, MetroMax Q, and quikSLOT — allow flexibility to meet changing needs. Can be positioned in 1" (25mm) increments along the entire height of post.
- Double Door: Each door opens 270 degrees and can be secured along the sides of the unit.
- Shipped Knocked-Down: Saves on freight costs. Easily assembled.











MetroMax Q Security Unit



Super Adjustable Super Erecta Security Unit

## Ordering Guide for Security Units

	DRY ENVIRONMENTS		WET ENVIRONMENTS		
1) Choose the right finish and shelving style based on the usage environment and/or cleaning methods.	Super Erecta Chrome Finish	quikSLOT Chrome Finish	Super Erecta Metroseal 3 Finish	MetroMax Q Polymer & Epoxy Coated Steel Finish	Super Erecta Type 304 Stainless Steel Finish
Corrosion protection	N/A	N/A	Corrosion Resistant	Corrosion Resistant	Corrosion Proof
NSF Listed	YES	NO	YES	YES	YES
2) Choose from Stationary and Mobile Options.					
Stationary	8 Models	5 Models	5 Models	3 Models	8 Models
Mobile: Medium-Duty Recommended security models with stem casters.	 DC & EC Models Include casters with zinc-plated horns	 DCQ & ECQ Models Include casters with zinc-plated horns	 VK3 Models Include casters with polymer horns	 VE Models Include casters with polymer horns	Casters are NOT provided with Stainless Steel Standard-Duty Stem Caster base models. Casters are sold separately for "SD" models.
Mobile: Heavy-Duty applications are best addressed by carts with dolly bases. Recommended when the cart will frequently be moved long distances, over doorways and thresholds, or between facilities or buildings. NOTE: Super Erecta security units are most often selected for these applications.	 Dollies/casters included LC Models	 Dollies/casters included LCQ Models	 Dollies/casters included LK3 Models	 Dollies/casters included LE Models	Dollies and plate casters are NOT provided with the Heavy-Duty Stainless Steel base models. Dollies & plate casters are ordered separately S-HD Models
3) Select Intermediate Shelves. Intermediate shelves are not included with base models.					



SEC55C shown with optional Super Adjustable intermediate shelves.

Super Erecta® Shelf Stationary Security — 66<sup>13</sup>/<sub>16</sub>" (1695mm) high  
Intermediate shelves are not included with base models and must be ordered separately. See page 105 for intermediate shelf options.

Width (in.) (mm)	Length (in.) (mm)	Fits Shelf (in.) (mm)		Approx. Pkd. Wt. (lbs.) (kg)	Cat. No. Chrome	Cat. No. Metroseal 3 with Microban®	Cat. No. Stainless Steel
21 <sup>1</sup> / <sub>2</sub>	546	38 <sup>1</sup> / <sub>2</sub>	980	18x36 457x914	138 63	SEC33C	SEC33K3
21 <sup>1</sup> / <sub>2</sub>	546	50 <sup>1</sup> / <sub>2</sub>	1295	18x48 457x1219	157 71	SEC35C	SEC35K3
27 <sup>1</sup> / <sub>4</sub>	692	38 <sup>1</sup> / <sub>2</sub>	980	24x36 610x914	154 70	SEC53C	SEC53K3
27 <sup>1</sup> / <sub>4</sub>	692	50 <sup>1</sup> / <sub>2</sub>	1295	24x48 610x1219	174 79	SEC55C	SEC55K3
27 <sup>1</sup> / <sub>4</sub>	692	62 <sup>1</sup> / <sub>2</sub>	1587	24x60 610x1524	195 89	SEC56C	SEC56K3
33 <sup>1</sup> / <sub>2</sub>	851	38 <sup>1</sup> / <sub>2</sub>	980	30x36 760x914	167 76	SEC63C	SEC63S
33 <sup>1</sup> / <sub>2</sub>	851	50 <sup>1</sup> / <sub>2</sub>	1295	30x48 760x1219	193 88	SEC65C	SEC65S
33 <sup>1</sup> / <sub>2</sub>	851	62 <sup>1</sup> / <sub>2</sub>	1587	30x60 760x1524	215 98	SEC66C	SEC66S



SEC55DC shown with optional Super Adjustable intermediate shelves (sold separately). Doors rotate 270° and can be secured to the sides of the cart while contents are being loaded on the shelves.

Super Erecta® Mobile Security

Standard-Duty Stem Caster Models — Chrome and Metroseal 3

Chrome and Metroseal 3 Standard-Duty Stem Caster Models include 5" (127mm) casters.

Intermediate shelves are not included with base models and must be ordered separately. See page 105 for intermediate shelf options.

Caster Type	Width (in.) (mm)	Length (in.) (mm)	Fits Shelf (in.) (mm)		Approx. Pkd. Wt. (lbs.) (kg)	Cat. No. Chrome	Cat. No. Metroseal 3 with Microban®
(2) 5MP/(2) 5MPB	21 <sup>1</sup> / <sub>2</sub>	546	40 <sup>3</sup> / <sub>4</sub>	1035	18x36 457x914	146 66	SEC33EC
(2) 5MP/(2) 5MPB	21 <sup>1</sup> / <sub>2</sub>	546	52 <sup>3</sup> / <sub>4</sub>	1340	18x48 457x1219	165 75	SEC35EC
(4) 5MP	27 <sup>1</sup> / <sub>4</sub>	692	40 <sup>3</sup> / <sub>4</sub>	1035	24x36 610x914	162 74	SEC53DC
(4) 5MP	27 <sup>1</sup> / <sub>4</sub>	692	52 <sup>3</sup> / <sub>4</sub>	1340	24x48 610x1219	182 83	SEC55DC
(4) 5MP	27 <sup>1</sup> / <sub>4</sub>	692	65	1651	24x60 610x1524	203 92	SEC56DC
(2) 5MP/5MPB	27 <sup>1</sup> / <sub>4</sub>	692	40 <sup>3</sup> / <sub>4</sub>	1035	24x36 610x914	162 74	SEC53EK3
(2) 5MP/5MPB	27 <sup>1</sup> / <sub>4</sub>	692	52 <sup>3</sup> / <sub>4</sub>	1340	24x48 610x1219	182 83	SEC55EK3
(2) 5MP/5MPB	27 <sup>1</sup> / <sub>4</sub>	692	65	1651	24x60 610x1524	203 92	SEC56EK3
(2) 5PC/5PCB	27 <sup>1</sup> / <sub>4</sub>	692	40 <sup>3</sup> / <sub>4</sub>	1035	24x36 610x914	162 74	SEC53VK3
(2) 5PC/5PCB	27 <sup>1</sup> / <sub>4</sub>	692	52 <sup>3</sup> / <sub>4</sub>	1340	24x48 610x1219	182 83	SEC55VK3
(2) 5PC/5PCB	27 <sup>1</sup> / <sub>4</sub>	692	65	1651	24x60 610x1524	203 92	SEC56VK3
(2) 5MP/(2) 5MPB	33 <sup>1</sup> / <sub>2</sub>	851	40 <sup>3</sup> / <sub>4</sub>	1035	30x36 760x914	175 80	SEC63EC
(2) 5MP/(2) 5MPB	33 <sup>1</sup> / <sub>2</sub>	851	52 <sup>3</sup> / <sub>4</sub>	1340	30x48 760x1219	202 92	SEC65EC
(2) 5MP/(2) 5MPB	33 <sup>1</sup> / <sub>2</sub>	851	65	1651	30x60 760x1524	223 101	SEC66EC

Casters: 5MP and 5MPB (with locking brake) feature a polyurethane tread. 5PC and 5PCB (with locking brake) casters feature a polymer horn and resist rusting. They are recommended for high-moisture environments. Large casters can create a tipping hazard. On security units using 18" (457mm) deep shelving, do not use casters larger than 5" (127mm) in diameter. Overall height: Models with 5MP casters — 67<sup>15</sup>/<sub>16</sub>" (1726mm) high. Models with 5PC casters — 68<sup>7</sup>/<sub>16</sub>" (1739mm) high.



SEC55LC shown with optional Super Adjustable intermediate shelves.

Heavy-Duty Models — Chrome and Metroseal 3 — 68<sup>7</sup>/<sub>16</sub>" (1739mm) high

Chrome and Metroseal 3 models feature aluminum dollies with wraparound bumpers and 5" (127mm) diameter casters.

Caster Type	Width (in.) (mm)	Length (in.) (mm)	Fits Shelf (in.) (mm)		Approx. Pkd. Wt. (lbs.) (kg)	Cat. No. Chrome	Cat. No. Metroseal 3 with Microban®
(2) B5P/B5PB	28 <sup>1</sup> / <sub>16</sub>	713	38 <sup>1</sup> / <sub>2</sub>	980	24x36 610x914	187 85	SEC53LC
(2) B5P/B5PB	28 <sup>1</sup> / <sub>16</sub>	713	50 <sup>1</sup> / <sub>2</sub>	1285	24x48 610x1219	210 95	SEC55LC
(2) B5P/B5PB	28 <sup>1</sup> / <sub>16</sub>	713	63 <sup>1</sup> / <sub>8</sub>	1600	24x60 610x1524	235 107	SEC56LC

**NSF** Note: Super Erecta Security Units are NSF listed.



✓ Indicates antimicrobial product.

### Standard-Duty Stem Caster Models — Stainless Steel — 62" (1575mm) high

Casters must be ordered separately. See pages 50-51, or consult your Metro representative for the proper caster for your application. Intermediate shelves are not included with base models and must be ordered separately.

Description	Width (in.) (mm)	Length (in.) (mm)	Fits Shelf (in.) (mm)		Approx. Pkd. Wt. (lbs.) (kg)		Cat. No. Stainless Steel
Standard Duty	21½ 546	40¾ 1035	18x36	457x914	138	63	SEC33S-SD
Standard Duty	21½ 546	52¾ 1340	18x48	457x1219	157	71	SEC35S-SD
Standard Duty	27¼ 692	40¾ 1035	24x36	610x914	154	70	SEC53S-SD
Standard Duty	27¼ 692	52¾ 1340	24x48	610x1219	174	79	SEC55S-SD
Standard Duty	27¼ 692	65 1651	24x60	610x1524	195	89	SEC56S-SD
Standard Duty	33½ 851	40¾ 1035	30x36	760x914	167	76	SEC63S-SD
Standard Duty	33½ 851	52¾ 1340	30x48	760x1219	193	88	SEC65S-SD
Standard Duty	33½ 851	65 1651	30x60	760x1524	215	98	SEC66S-SD

**Note:** Given height is for unit without casters. For approximate overall unit height add chosen caster diameter plus 1" (25mm).  
**Note:** Large casters can create a tipping hazard. On security units using 18" (457mm) deep shelving, do not use casters larger than 5" (127mm) in diameter.

**Metro Tip:**  
**Caster Selection:**  
 For highly corrosive environments, choose casters constructed of appropriate materials. While most wheels are corrosion resistant, the horns and axles are not. Select from a variety of Metro casters with polymer and stainless components. See pages 50-51 and 53 for more information.

### Heavy-Duty Models — Stainless Steel — 62" (1575mm) high

Heavy-duty stainless steel models include staked posts for use with standard Metro dollies. Dolly bases and plate casters must be ordered separately. See pages 52-54, or consult your Metro representative for the proper caster for your application. Intermediate shelves are not included with base models and must be ordered separately.

Description	Width (in.) (mm)	Length (in.) (mm)	Fits Shelf (in.) (mm)		Approx. Pkd. Wt. (lbs.) (kg)		Cat. No. Stainless Steel
Heavy Duty	28½ 713	38½ 980	24x36	610x914	154	70	SEC53S-HD
Heavy Duty	28½ 713	50½ 1285	24x48	610x1219	174	79	SEC55S-HD
Heavy Duty	28½ 713	63⅞ 1600	24x60	610x1524	195	89	SEC56S-HD

**Note:** Given height is for unit without a Metro dolly or casters.  
**Note:** To calculate the actual height of the unit using plate casters: 62" [1575mm] + ¼" [6mm] for dolly + load height of the caster (found on page 51).

Dolly bases are recommended for applications where security units will be transported over the road. Please consult your Metro representative for the appropriate casters and accessories for these applications.

### Intermediate Shelves for Super Erecta Shelf Security Units

Width (in.) (mm)	Length (in.) (mm)	Approx. Pkd. Wt. (lbs.) (kg)		Cat. No. Chrome	Cat. No. Metroseal 3 with Microban®	Cat. No. Stainless Steel	Cat. No. Super Erecta Pro
18	457	36	914	9½ 4.3	A1836NC	A1836NK3	A1836NS PR1836NK3
18	457	48	1219	12 5.4	A1848NC	A1848NK3	A1848NS PR1848NK3
24	610	36	914	13 6	A2436NC	A2436NK3	A2436NS PR2436NK3
24	610	48	1219	16 7	A2448NC	A2448NK3	A2448NS PR2448NK3
24	610	60	1524	21 9.5	A2460NC	A2460NK3	A2460NS PR2460NK3
30	760	36	914	15 6.8	A3036NC		A3036NS
30	760	48	1219	21 9.5	A3048NC		A3048NS
30	760	60	1524	26½ 11.8	A3060NC		A3060NS

**Note:** Standard Super Erecta shelves can also be used as intermediate shelves. Refer to page 42 for more information.

### Super Erecta Security Modules — 14.01

Convert a standard 24" (610mm) wide unit into a security module with this convenient kit.

- Used to enclose one or more areas of a unit.
- Fits between shelves spaced 20" (510mm) apart on any Super Erecta Shelving unit.
- Adapts to 24" (610mm) wide shelves in 30," 48" and 60" (760, 1219 and 1524mm) lengths.

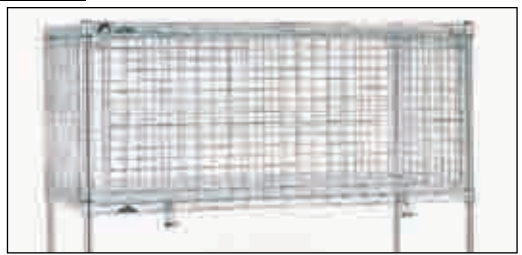

SECM2430NC  
Assembled on Shelving Unit

Width/Length (in.) (mm)	Height (in.) (mm)	Approx. Pkd. Wt. (lbs.) (kg)		Cat. No. Chrome	Cat. No. Stainless Steel
24x30 610x760	20 510	29¼ 14		SECM2430NC	SECM2430NS
24x48 610x1219	20 510	39¾ 18		SECM2448NC	*
24x60 610x1524	20 510	45¾ 21		SECM2460NC	*

**Note:** Security Module consists of side panels, back panels and door. Posts and shelves sold separately, see page 42.  
**When multiple security modules are stacked on one shelving unit, separate top and bottom shelves are still necessary for each module.**  
 Security modules must be used with Super Erecta Shelf wire shelves.  
 \*Consult your Metro representative for availability.

✓ Indicates antimicrobial product.





SEC53DCQ shown with Intermediate Shelves (optional)

qwikSLOT™ Security Units — 14.01

- Add/Remove-A-Shelf Feature: Allows the unit to quickly adapt to your changing storage needs.
- Shelves can be adjusted easily in seconds.
- Models include two standard Super Erecta shelves which must be used as the top and bottom shelves of the unit. qwikSLOT intermediate shelves are sold separately.

qwikSLOT Stationary Security

Caster Type	Width (mm)		Actual Length (mm)		Height (mm)		Fits Shelf (mm)		Approx. Pkd. Wt. (lbs./kg)		Cat. No. Chrome
	(in.)	(mm)	(in.)	(mm)	(in.)	(mm)	(in.)	(mm)	(lbs.)	(kg)	
	21½	546	38½	980	66 <sup>13</sup> / <sub>16</sub>	1695	18x36	457x914	138	63	SEC33CQ
	21½	546	50½	1283	66 <sup>13</sup> / <sub>16</sub>	1695	18x48	457x1219	157	71	SEC35CQ
	27¼	705	38½	980	66 <sup>13</sup> / <sub>16</sub>	1695	24x36	610x914	154	70	SEC53CQ
	27¼	705	50½	1283	66 <sup>13</sup> / <sub>16</sub>	1695	24x48	610x1219	174	79	SEC55CQ
	27¼	705	62½	1587	66 <sup>13</sup> / <sub>16</sub>	1695	24x60	610x1524	195	89	SEC56CQ

qwikSLOT Mobile Security

Standard-Duty Stem Caster Models: feature 5" (127mm) swivel casters. Please note model numbers for specific caster types.

Caster Type	Width (mm)		Actual Length (mm)		Height (mm)		Fits Shelf (mm)		Approx. Pkd. Wt. (lbs./kg)		Cat. No. Chrome
	(in.)	(mm)	(in.)	(mm)	(in.)	(mm)	(in.)	(mm)	(lbs.)	(kg)	
(2) 5MP/5MPB	21½	546	40¾	1035	67 <sup>15</sup> / <sub>16</sub>	1726	18x36	457x914	146	66	SEC33ECQ
(2) 5MP/5MPB	21½	546	52¾	1340	67 <sup>15</sup> / <sub>16</sub>	1726	18x48	457x1219	165	75	SEC35ECQ
(4) 5MP	27¼	692	40¾	1035	67 <sup>15</sup> / <sub>16</sub>	1726	24x36	610x914	162	74	SEC53DCQ
(4) 5MP	27¼	692	52¾	1340	67 <sup>15</sup> / <sub>16</sub>	1726	24x48	610x1219	182	83	SEC55DCQ
(4) 5MP	27¼	692	65	1651	67 <sup>15</sup> / <sub>16</sub>	1726	24x60	610x1524	203	92	SEC56DCQ
(2) 5MP/5MPB	27¼	692	40¾	1035	67 <sup>15</sup> / <sub>16</sub>	1726	24x36	610x914	162	74	SEC53ECQ
(2) 5MP/5MPB	27¼	692	52¾	1340	67 <sup>15</sup> / <sub>16</sub>	1726	24x48	610x1219	182	83	SEC55ECQ
(2) 5MP/5MPB	27¼	692	65	1651	67 <sup>15</sup> / <sub>16</sub>	1726	24x60	610x1524	203	92	SEC56ECQ

Casters: 5MP and 5MPB (with locking brake) feature a polyurethane tread. 5PC and 5PCB (with locking brake) casters feature a polymer horn and resist rusting. They are recommended for high moisture environments.

**NOTE:** Large casters can create a tipping hazard. On 18" (457mm) security units, do not use casters larger than 5" (127mm) in diameter.



Clips snap easily into slots along post length to support shelves.



**qwikSLOT Locking Clip**  
Recommended for mobile applications. Must be used with 9985QS shelf clips. (Package of 4)  
Cat. No. **9985QSL**

Heavy-Duty Models: feature aluminum dollies with wraparound bumpers and 5" (127mm) diameter casters.

Caster Type	Width (mm)		Actual Length (mm)		Height (mm)		Fits Shelf (mm)		Approx. Pkd. Wt. (lbs./kg)		Cat. No. Chrome
	(in.)	(mm)	(in.)	(mm)	(in.)	(mm)	(in.)	(mm)	(lbs.)	(kg)	
(2) 5BP/5BPB	28 <sup>1</sup> / <sub>16</sub>	713	38½	980	68 <sup>7</sup> / <sub>16</sub>	1739	24x36	610x914	187	85	SEC53LCQ
(2) 5BP/5BPB	28 <sup>1</sup> / <sub>16</sub>	713	50½	1283	68 <sup>7</sup> / <sub>16</sub>	1739	24x48	610x1219	210	95	SEC55LCQ
(2) 5BP/5BPB	28 <sup>1</sup> / <sub>16</sub>	713	63 <sup>1</sup> / <sub>8</sub>	1600	68 <sup>7</sup> / <sub>16</sub>	1739	24x60	610x1524	235	107	SEC56LCQ

Intermediate Shelves for Super Erecta Shelf Security Units

Width (in.)	Length (mm)	Approx. Pkd. Wt. (lbs./kg)		Cat. No. Chrome	
		(lbs.)	(kg)		
18	457	36	914	8½ 3.8	1836QBR
18	457	48	1219	11¼ 5.0	1848QBR*
24	610	36	914	13 6.0	2436QBR*
24	610	48	1219	16 7.0	2448QBR*
24	610	60	1524	21 9.5	2460QBR

\*Chrome qwikSLOT shelves available in sizes 18x36, 18x48, 24x36, and 24x48 (457x914, 457x1219, 610x914, 610x1219, and 610x1524).

\*\*Drop Mat qwikSLOT shelves with 1" (25mm) ledge also available in sizes 24x36, 24x48 (610x914, 610x1219).

# MetroMax iQ™ Storage System

# Security.

## MetroMax Q Security Units — 14.01

Protects valuable materials and sensitive items from loss or pilferage.

- Ready view of contents: Heavy gauge open wire construction keep contents visible at all times, making it easy to check inventory.
- Microban antimicrobial product protection is built into the enclosures, doors, handles, and shelves to keep the product “cleaner between cleanings.”
- Optional intermediate shelves: MetroMax Q quick adjust shelves or corrosion proof MetroMax i.
- Double door with ergonomic ¼-turn handle: Each door opens 270 degrees and can be secured along the sides of the unit.
- Shipped knocked down to save on freight costs. Assembles in minutes.



MQSEC53VE with optional intermediate shelves

Standard Units consist of top and bottom wire shelves, tri-lobal adapters, steel posts, wire enclosures, and doors. Casters are included with mobile units. Intermediate shelves are sold separately.

## MetroMax Q Stationary Units — 66<sup>3</sup>/<sub>16</sub>" (1681mm) High

Actual Outside Dimensions				Fits Shelf		Approx. Pkd. Wt.		Cat. No.
Width		Length		(in.)	(mm)	(lbs.)	(kg)	
(in.)	(mm)	(in.)	(mm)	(in.)	(mm)	(lbs.)	(kg)	
26 <sup>15</sup> / <sub>16</sub>	685	38 <sup>7</sup> / <sub>8</sub>	987	24x36	610x914	148	67	<b>MQSEC53E</b>
26 <sup>15</sup> / <sub>16</sub>	685	50 <sup>7</sup> / <sub>8</sub>	1292	24x48	610x1219	156	71	<b>MQSEC55E</b>
26 <sup>15</sup> / <sub>16</sub>	685	62 <sup>7</sup> / <sub>8</sub>	1597	24x60	610x1524	161	73	<b>MQSEC56E</b>

Note: Leveling foot on post can be adjusted up to 1" (25mm) to compensate for uneven floors.

## MetroMax Q Stem Caster Mobile Units — 67<sup>13</sup>/<sub>16</sub>" (1723mm) High

Models include four 5" (127mm) diameter casters with polyurethane tread; two swivel and two swivel with brakes.

Actual Outside Dimensions (including Bumpers and Handle)				Fits Shelf		Approx. Pkd. Wt.		Cat. No. Includes Casters with Plated Finish		Cat. No. Includes Corrosion Resistant Polymer Casters	
Width		Length		(in.)	(mm)	(lbs.)	(kg)				
(in.)	(mm)	(in.)	(mm)	(in.)	(mm)	(lbs.)	(kg)				
27 <sup>13</sup> / <sub>16</sub>	707	40 <sup>3</sup> / <sub>4</sub>	1035	24x36	610x914	166	75	<b>MQSEC53DE</b>	<b>MQSEC53VE</b>		
27 <sup>13</sup> / <sub>16</sub>	707	52 <sup>3</sup> / <sub>4</sub>	1340	24x48	610x1219	176	80	<b>MQSEC55DE</b>	<b>MQSEC55VE</b>		
27 <sup>13</sup> / <sub>16</sub>	707	64 <sup>3</sup> / <sub>4</sub>	1645	24x60	610x1524	179	81	<b>MQSEC56DE</b>	<b>MQSEC56VE</b>		

\*\*"DE" models use two SMPX and two SMPBX casters.

\*\*\*"VE" models use two 5PCX and two 5PCBX casters. Recommended for wet or damp environments.

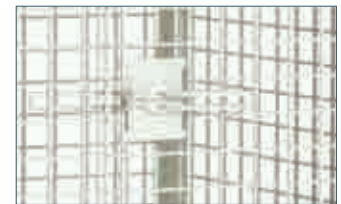

Ergonomic — ¼ turn door handle

## MetroMax Q Heavy-Duty Mobile Units — 68<sup>1</sup>/<sub>2</sub>" (1740mm) High

Mounted on aluminum dolly with 5" (127mm) plate casters and wraparound bumpers.

Actual Outside Dimensions (including Handle)				Fits Shelf		Approx. Pkd. Wt.		Cat. No.
Width		Length		(in.)	(mm)	(lbs.)	(kg)	
(in.)	(mm)	(in.)	(mm)	(in.)	(mm)	(lbs.)	(kg)	
28 <sup>1</sup> / <sub>16</sub>	713	39 <sup>7</sup> / <sub>8</sub>	994	24x36	610x914	166	75	<b>MQSEC53LE</b>
28 <sup>1</sup> / <sub>16</sub>	713	51 <sup>1</sup> / <sub>8</sub>	1299	24x48	610x1219	176	80	<b>MQSEC55LE</b>
28 <sup>1</sup> / <sub>16</sub>	713	63 <sup>1</sup> / <sub>8</sub>	1603	24x60	610x1524	179	81	<b>MQSEC56LE</b>

Note: The aluminum dollies used on the LE models have two B5P and two B5PB plate casters.



## Intermediate Shelves

Width (in.) (mm)	Length (in.) (mm)	Cat. No.		
		Shelf with Grid Mat	Shelf with Solid Mat	Shelf with Grid Mat
24	610	<b>MX2436G</b>	<b>MX2436F</b>	<b>MQ2436G</b>
24	610	<b>MX2448G</b>	<b>MX2448F</b>	<b>MQ2448G</b>
24	610	<b>MX2460G</b>	<b>MX2460F</b>	<b>MQ2460G</b>

Seismic Shelving Systems

Super Erecta® (SES), Super Adjustable Super Erecta® (SASE), qwikSLOT™ (QS), HD Super (HD), MetroMax Q® (Q)

Seismic Bolt Plates Kits:

For 1" (25mm) diameter, Super Erecta Shelf, Super Adjustable Super Erecta, qwikSLOT stationary post assemblies. Kit includes plate assemblies and hardware to mount plates to posts. Floor anchors are not included.

Description	Qty.	Dimensions (Width/Length/Height)		Cat. No.
		(in.)	(mm)	
One-Post Bolt Plate, 1/4" (6mm)	4	2 <sup>7</sup> / <sub>8</sub> x7x <sup>1</sup> / <sub>4</sub>	73x178x6	SASES25BP-1
Two-Post Bolt Plate, 1/4" (6mm)	2	2 <sup>7</sup> / <sub>8</sub> x11x <sup>1</sup> / <sub>4</sub>	73x279x6	SASES25BP-2
Four-Post Bolt Plate, 1/4" (6mm)	1	2 <sup>7</sup> / <sub>8</sub> x11x <sup>1</sup> / <sub>4</sub>	73x279x6	SASES25BP-4
One-Post Bolt Plate, 1/2" (13mm)	4	7x7x <sup>1</sup> / <sub>2</sub>	178x178x13	SASES50BP-1
Two-Post Bolt Plate, 1/2" (13mm)	2	7x12x <sup>1</sup> / <sub>2</sub>	178x305x13	SASES50BP-2
Four-Post Bolt Plate, 1/2" (13mm)	1	7x12x <sup>1</sup> / <sub>2</sub>	178x305x13	SASES50BP-4

For 1.5" (38mm) diameter HD and trilobal Q stationary post assemblies. Kit includes plates and hardware to mount plates to posts. Floor anchors are not included.

Description	Qty.	Dimensions (Width/Length/Height)		Cat. No.
		(in.)	(mm)	
One-Post Bolt Plate, 1/4" (6mm)	4	2 <sup>7</sup> / <sub>8</sub> x7x <sup>1</sup> / <sub>4</sub>	73x178x6	SAQHD25BP-1
Two-Post Bolt Plate, 1/4" (6mm)	2	2 <sup>7</sup> / <sub>8</sub> x11x <sup>1</sup> / <sub>4</sub>	73x279x6	SAQHD25BP-2
Four-Post Bolt Plate, 1/4" (6mm)	1	2 <sup>7</sup> / <sub>8</sub> x11x <sup>1</sup> / <sub>4</sub>	73x279x6	SAQHD25BP-4
One-Post Bolt Plate, 1/2" (13mm)	4	7x7x <sup>1</sup> / <sub>2</sub>	178x178x13	SAQHD50BP-1
Two-Post Bolt Plate, 1/2" (13mm)	2	7x12x <sup>1</sup> / <sub>2</sub>	178x305x13	SAQHD50BP-2
Four-Post Bolt Plate, 1/2" (13mm)	1	7x12x <sup>1</sup> / <sub>2</sub>	178x305x13	SAQHD50BP-4

**Required Components:**  
For seismic requirements, simply add floor bolt-plates to standard Metro stationary shelving configurations and follow the installation and usage guidelines. Just add floor plates

**Example A**  
Requires one 1-post starter kit. (ie. SASES25BP-1).

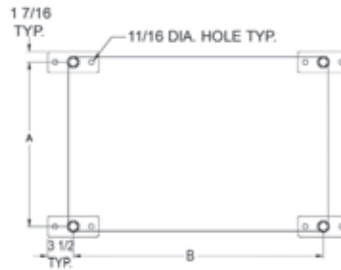

**Example B**  
Requires one starter kit, (ie. SASES25BP-1) and one 2-post adder kit, (ie. SASES25BP-2). Include one additional adder kit for each subsequent shelving unit added to the run.

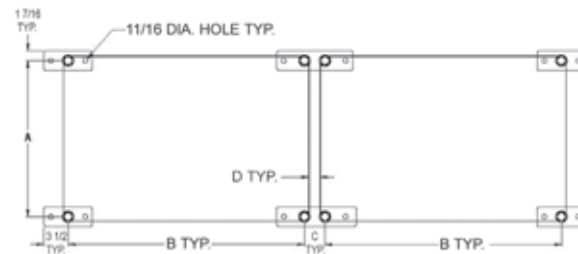

**Example C**  
Requires one 1-post starter kit, (ie. SASES25BP-1), two 2-post adder kits (ie. SASES25BP-2), and one 4-post adder kit, (ie. SASES25BP-4). Include one of each adder kit, (ie. one 2-post kit and one 4-post kit), for each additional pair of shelving units.

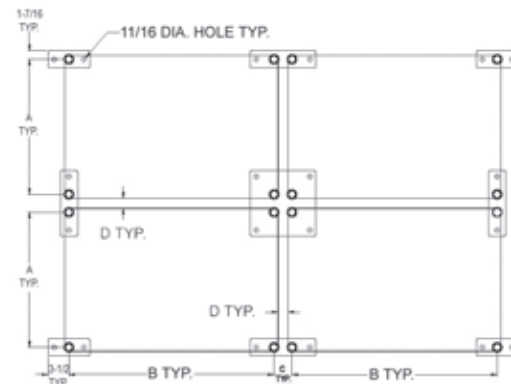

Super Adjustable Super Erecta, Super Erecta®, qwikSLOT™

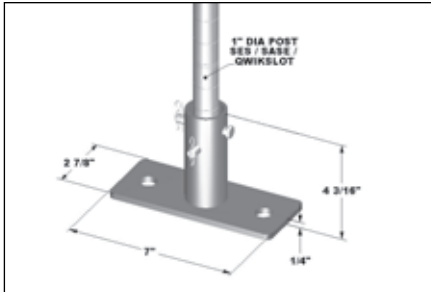

SASES25BP-1

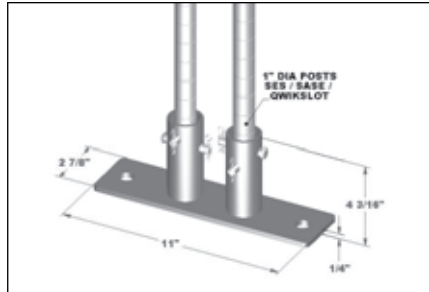

SASES25BP-2

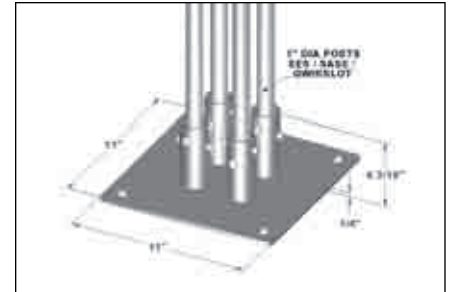

SASES25BP-4

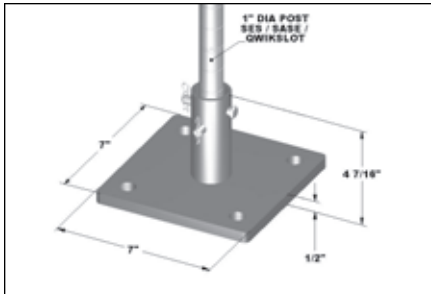

SASES50BP-1

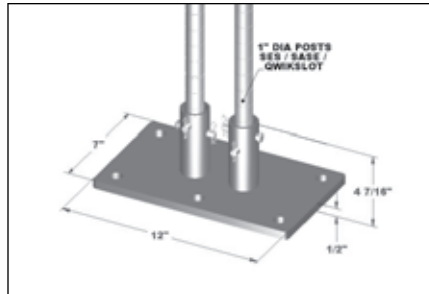

SASES50BP-2

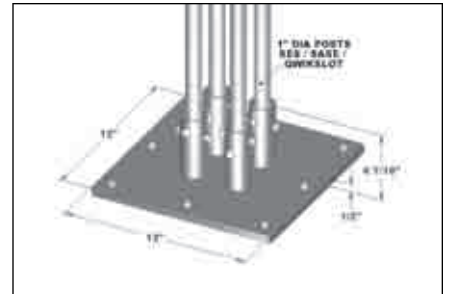

SASES50BP-4

Hint: It is recommended that a donut bumper be specified to cover any spaces between the post and the bolt plate anchor pipe. Specify the donut bumper to match the post type.



Super Erecta, Super Adjustable Super Erecta, qwikSLOT = 9992DB  
 Super Erecta Shelf HD = 9992H  
 MetroMax Q = 9992DBX

MetroMax Q®/HD Super

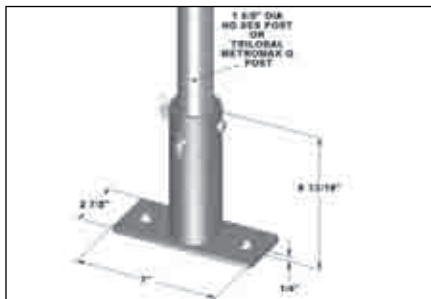

SAQHDS25BP-1

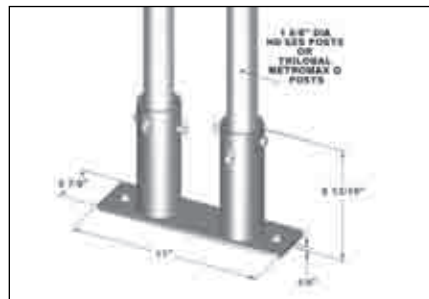

SAQHD25BP-2

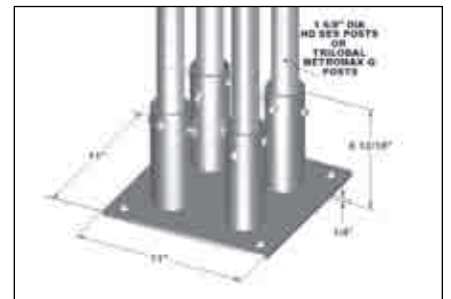

SAQHD25BP-4

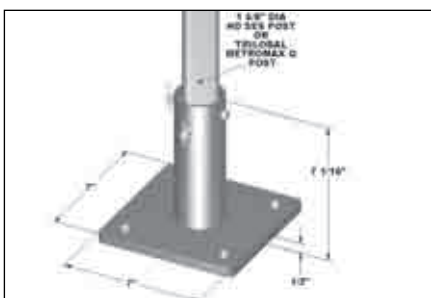

SAQHD50BP-1

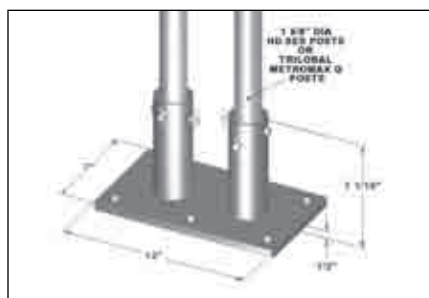

SAQHD50BP-2

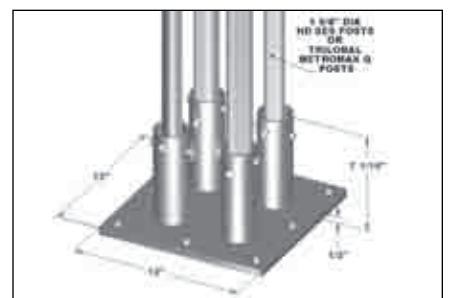

SAQHD50BP-4

“YOU CAN DO IT...  
Visit us online and take  
advantage of our easy-to-use  
self-service tools.”



Self-service Tools Available...online!

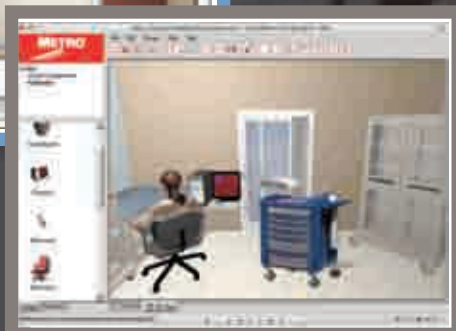
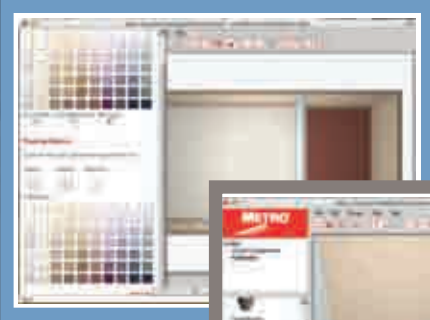

- Web-based Room Layout and Product Planning
- Web-based Product Configuration
- Web-based Learning Modules

[metroconfigurator.com](http://metroconfigurator.com)



Visit [metroconfigurator.com](http://metroconfigurator.com) and test drive the Configurator...our web based software developed to give you the power to manage your space.

# CONTENTS

## **Point-of-Care Computing Medication Management.....112-137**

Point-of-Care Mobile Workstations.....	114-121
Automated Dispensing Systems .....	122-125
Medication Carts & Wall Cabinets.....	126-129
Pharmacy Fixtures.....	130-135
MetroESP Enhanced Service Program .....	136-137

## **Enclosed Storage, Transport & WorkStations .....138-173**

Overview.....	140
Cart Overview .....	141
Procedure Carts — Modular .....	142-150
Supply Units/Carts/Cabinets & Accessories .....	151-159
Mobile WorkCenters .....	160-161
Stationary WorkCenters & Accessories .....	162-166
Overhead Units & Accessories.....	167-169
Specialty Units/Storage & Accessories.....	170-172

## **Carts.....174-229**

Emergency Carts .....	176-181
Procedure Carts — Polymer .....	182-193
Procedure Carts — Metal .....	194-211
Case Carts .....	212-213
Procedural Support .....	214
Specialty Carts & Storage .....	215-218
Storage & Transport/Exchange Carts .....	219-225
Totes, Slides & Accessories.....	226-227
Linen Carts and Trucks.....	228-229

## **Work Stations.....230-237**

Process Tables & Accessories .....	232-235
Worktables & Accessories.....	236-237

# Metro<sup>®</sup> healthcare solutions:



# Care. Virtually Everywhere.™

## POINT-OF-CARE COMPUTING

Mobile Workstations  
Hybrid Medication Workstations  
Wall Systems

## MEDICATION MANAGEMENT

Automated Dispensing  
Fixtures  
Medication Carts

## CLINICAL PRODUCTS

Carts  
Shelving  
Workstations





## The Ultimate in Comfort, Convenience and Flexibility

With over 30,000 workstations in facilities all over the world, Metro® is established as a leading provider of mobile computing systems. Our latest innovation, Metro AccessPoint™ has been designed to provide an unmatched user experience to both caregivers and IT professionals. By optimizing technology and processes, the system streamlines workflow and makes facilities more efficient. With an array of new ergonomic features, a reconstructed platform, and next-generation power options, the workstation provides comfort and convenience for any clinician with unparalleled flexibility for long-term value.



# TRUE ERGONOMIC DESIGN FOR THE ULTIMATE USER EXPERIENCE

- 1 Supports a wide variety of display options, including touch screens, all-in-one computers and monitors up to 20 lbs.
- 2 Large, open work surface features Microban® antimicrobial protection.
- 3 Ergonomic keyboard tray provides 10° of positive tilt, 20° of negative tilt, 180° of rotation and 7" of independent height adjustment.



- 4 Robust column design provides a stable platform to support your workflow and accommodate a variety of accessories.
- 5 Compact footprint and easy-roll casters provide maximum maneuverability in tight spaces and over thresholds.

Designed from the ground up to meet the Cornell University Healthcare Cart Ergonomic Standards.

Microban® antimicrobial protection helps prevent the growth of stain and odor causing bacteria on the workstation. Microban® protection is not designed to protect users against disease causing microorganisms.

## UNIQUE FEATURES



### Electronic Lift

Optional electronic lift mechanism provides strain-free adjustment for a keyboard height range of 23" - 48".

### Fully-Adjustable Display Mount

Raise, lower, tilt, swivel or rotate the monitor to find the ideal viewing angle. A bifocal-friendly angle is available when needed. Monitor can also be lowered to provide enhanced visibility while traveling room to room.

### Integrated Footrest

Designed for maximum comfort and durability, the integrated footrest reduces fatigue and allows nurses to relax in a more ergonomic position throughout the day.

### Standard Keypad Controller

Easily power the computer on without IT involvement while providing access to battery level and task lighting.

### Ergonomic Push Handles

Contoured handles provide easy maneuverability.

### LED Task Lighting

Work surface and keyboard lights provide ample visibility when working in a patient room during night hours.

Contact a Metro representative  
to learn more:

**1.800.992.1776**

# ENGINEERED TO DELIVER ELITE PERFORMANCE & LONG-TERM FLEXIBILITY



Fully-integrated Metro AccessPoint™ workstations are engineered to deliver industry-leading performance and reliability. AccessPoint protects and supports your EMR investment by optimizing your technology and power system to extend battery life, limit downtime and improve clinician workflow. When you choose any of our fully-integrated solutions, your Metro AccessPoint will arrive at your facility fully assembled and ready-to-roll for fast and easy deployment.

## CHEMISTRY CYCLE COMPARISON (with typical hospital usage)

METRO OPTIONS	SLA+ LiFe Li-Nano
	SLA+ systems degrade almost immediately after initial use. LiFe provides constant performance for 2500 cycles. Li-Nano provides maximum performance for more than 5,000 cycles.

SLA+ systems degrade almost immediately after initial use.  
LiFe provides constant performance for 2500 cycles.  
Li-Nano provides maximum performance for more than 5,000 cycles.

**Twice  
the LiFe**

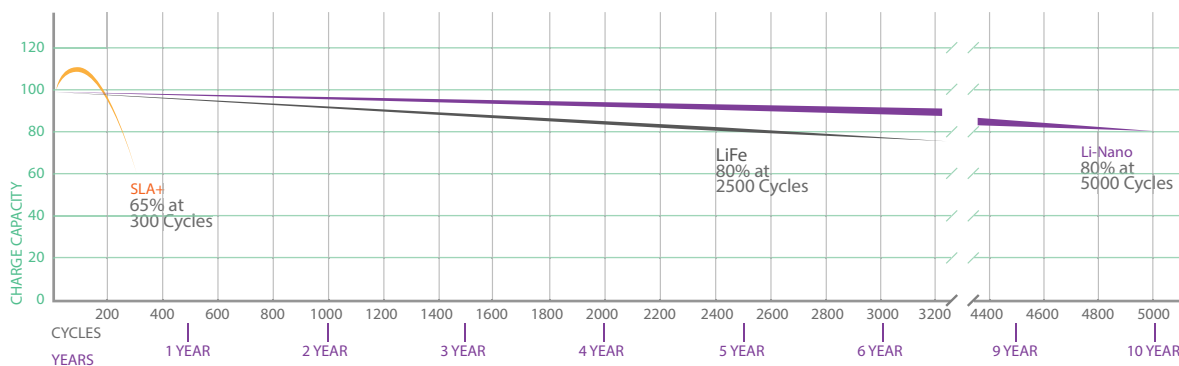
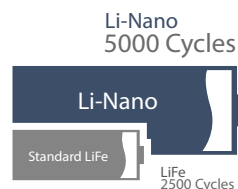

## The Power of Choice.

With three different chemistry options, Metro AccessPoint has a power system to meet both your workflow and your budget. Our advanced Li-Nano battery delivers twice the life of typical LiFe batteries and comes standard with an industry-leading 5-year warranty.



### Ready-to-integrate. Ready-to-deploy.

The innovative design of the Metro AccessPoint™ makes it easier than ever for IT and biomedical teams to integrate their own technology when time is of the essence.

Our new universal tech tray design accommodates technology from HP, Dell, Lenovo and more while expanding to accept laptops up to 17" for future upgrades. Also, the new tech tray features Wake-on-LAN/Wake-on-power capability, advanced wire management, and the ability to easily configure for AC or DC technology integration.



### Battery-only Replacement.

The advanced power system provides easy access for maintenance, upgrades and replacements. Batteries are independent from the electronics while future chemistry upgrades or replacements will consist of a "battery only" replacement.

### Budget Flexibility.

By offering the ability to upgrade the battery only without changing the entire power system, AccessPoint offers unique budget flexibility. Facilities can manage the initial investment by choosing a chemistry that fits their budget and later upgrade to a more advanced system to extend the life of the workstation.



### Charging options to fit your environment and workflow.

The next generation power system of the Metro AccessPoint offers greater flexibility when it comes to your charging options. The new fanless charging mode reduces the circulation of dust, debris and other harmful contaminants while quietly recharging your system in 3 hours. The fast-charge mode can replenish a depleted power supply in as little as 2 hours.



Contact a Metro representative  
to learn more:

**1.800.992.1776**



## AccessPoint™ Rx

Mobile Medication

The Metro AccessPoint™ Rx is a mobile medication workstation specifically designed to improve workflow by providing nurses with the information and medication they need where they need them most, the patient bedside. Features such as easy-to-use software, extended capacity for up to 12 individual patient bins and advanced ergonomics make the AccessPoint Rx the right solution for any facility looking to advance their BCMA process. For a more advanced level of security and control, the Metro AccessPoint Rx MD Mobile Medication System interfaces with the hospital's information system, eliminating wasteful and error-prone data entry.



Contact a Metro representative  
to learn more:

**1.800.992.1776**

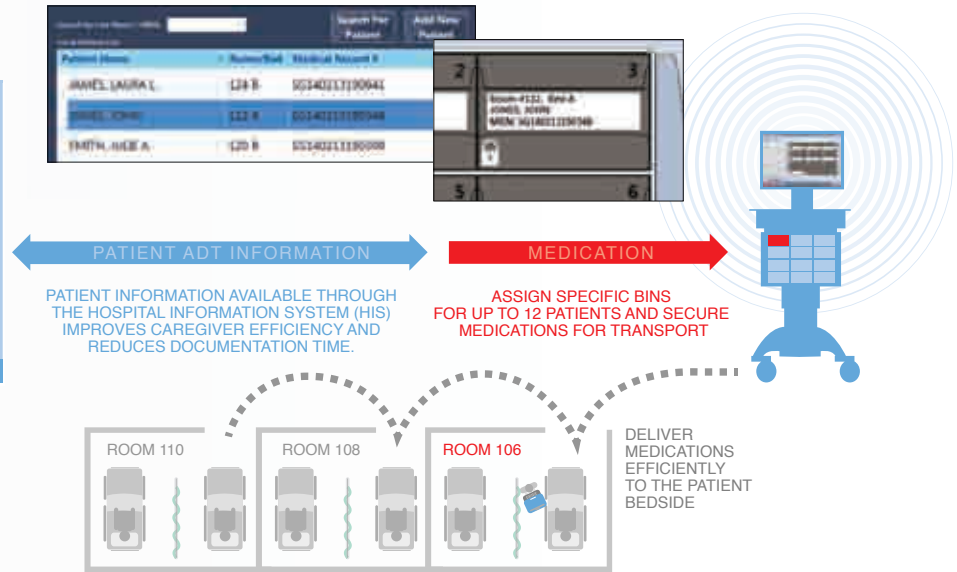

## PROVIDING NURSES WITH THE ULTIMATE USER EXPERIENCE

The Metro AccessPoint Rx MD Mobile Medication System, comprised of our workstation, client software and individual locking, patient-specific bins, promotes secure medication management processes from the automated dispensing cabinet or pharmacy to the patient bedside. The system interfaces with the hospital's information system, eliminating wasteful and error-prone data entry. The AccessPoint Rx MD improves nursing efficiency, enables good medication delivery practices, increases security, and makes doing the right thing, the easiest thing.

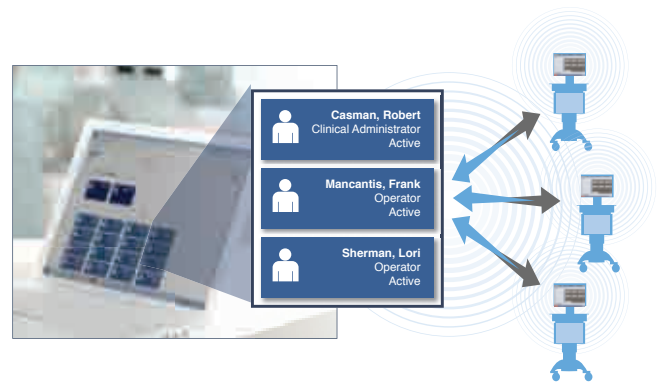

## PROVIDING THE PHARMACY WITH UNPARALLELED CONTROL

The Metro AccessPoint Rx MD system brings control to pharmacists' fingertips with improved management, access and flexibility. With web-based access to Metro's console or use of the hospital's Active Directory to manage users, Metro provides the tools to better manage medication delivery.



EVERYTHING YOU NEED  
**ACCESSIBLE &  
 AVAILABLE**



MORE OPTIONS TO STORE, HOLD, AND SECURE THE ITEMS YOU USE EVERYDAY.



Utility Basket  
 #AP-ALUTILBASKET



Glove Box Holder  
 #AP-AL1GLOVH



Rear Accessory Bar  
 8" Accessory Rail #AP-AL8RAIL  
 14" Accessory Rail #AP-AL14RAIL  
 18" Accessory Rail #AP-AL18RAIL



Motorola Wireless Scanner  
 #AP-ASWMOTOROLA (Scanner)  
 #AP-ASMMOTOROLAW (Mount)



Standard Sharps Holder  
 #AP-ALSSHARPSH



Mouse Holder  
 #AP-AMHOLDER

## CORE CART SPECIFICATIONS

Work Surface Height Adjustment Range	23"- 48" (584 x 1219 mm)
Footprint	16.75" x 17.5" (425 x 445 mm)
Construction	Powder-coated, cast aluminum with Microban® antimicrobial protection. Anodized extruded aluminum column. Polymer work surface and touch points with Microban® antimicrobial protection.
Work surface	267 sq. in. (1723 sq cm)
Casters	Four swivel: two locking, two non-locking, low rolling resistance on all surfaces

## POWER OPTIONS

AC Powered / DC Powered

Battery Options	SLA+ Sealed Lead Acid	LiFe Lithium-Iron Phosphate (LiFePO <sub>4</sub> )	Li-Nano Lithium-Iron Nanophosphate
Battery Life	300-400 cycles	2,500 cycles	5,000+ cycles
Battery Runtime (@35 watts)	12 hours*	13 hours*	13 hours*
Charging Status Indicators	Continuous readout on LEDs; BatteryPro software	Continuous readout on LEDs; BatteryPro software	Continuous readout on LEDs; BatteryPro software
Recharge Time Fast Charge (Fan) Silent Charge (Fanless)	4-6 hrs 4-6 hrs	2 hours 3 hours	2 hours 3 hours
5-year Replacement	4	1	0
Battery Capacity	540Wh	512Wh	512Wh
Input Voltage	100-240 VAC @ 4.5 amps, max	100-240 VAC @ 4.5 amps, max	100-240 VAC @ 4.5 amps, max
Output Voltage DC	10.5-16 V unregulated 12-24 V selectable 5-10 V selectable	10.5-16 V unregulated 12-24 V selectable 5-10 V selectable	10.5-16 V unregulated 12-24 V selectable 5-10 V selectable
Optional AC	120 V, 60 Hz, 150 W	120 V, 60 Hz, 150 W	120 V, 60 Hz, 150 W
Power	150 W 200 W Peak	150 W 200 W Peak	150 W 200 W Peak
Battery Warranty	1 year	3 years	5 years

\*Actual runtime may vary depending on several factors such as technology configuration, battery age, usage pattern and power supply model/battery option. Runtime is based on continuous use using 35 Watts.

The information contained herein is correct at the time of publication. We reserve the right to alter specifications without prior notice.



Glove Box Holder (2-box)  
#AP-AL2GLOVEH



Hose Clip Organizers  
(3) #AP-AL3CHOSEORG, (6) #AP-AL6CHOSEORG



Pole Holder for 1" Pole  
#AP-ALSPOLEH



Waste Basket Holder  
#AP-ALSWASTEH



Chart Holder  
#AP-ALSCHARTH



iRocks Backlit Keyboard  
#AP-AKBACKLIT



iRocks Ultra-Slim Keyboard  
#AP-AKUSLIM

Contact a Metro representative  
to learn more:

**1.800.992.1776**



Metro's automated dispensing systems streamline inventory and medication management, increase efficiency and help to ensure a better patient and caregiver experience. The MedDispense® system provides the perfect combination of security, simplicity, affordability and support for acute and specialty care facilities of all sizes.

Easy-to-deploy,  
easy-to-use and even  
easier on your budget.

## The MedDispense® Advantage:

Secure 24/7 access.

Intuitive, user-friendly software.

Modular system configurable to your needs.

More affordable than typical systems.

Fast, responsive service and support.







# Flexible and Affordable.



MedDispense systems provide the safety and availability of an automated dispensing solution without the complexity of traditional higher priced systems.

Because the system provides full connectivity and integration with most operations software, medication use and costs are captured immediately upon dispensing, streamlining operations and improving reimbursement.



2 Door  
Combo Tower



4 Door  
Supply Tower



Base 72



Base 45 with Auxiliary Supply



Combo Tower



Base 25 Mini with Supply  
Tower

## Simple. Specific. Solutions.

The MedDispense system is scalable to the specific needs, and budgets, of diverse healthcare facilities. Configurations may include base units, auxiliary units, accessories and software. Our solutions are scalable for a wide spectrum of care settings including: long-term care, residential treatment centers, small & large hospitals.



Single wide and double wide  
locking return drawers  
available.



How does MedDispense offer an affordable alternative to med management?

- > No long-term contracts required.
- > Modular system to fit your needs.
- > Easy deployment with quick training.
- > Single, dedicated med drawers reduce needless errors.
- > 24/7 support for less downtime.



*Base 72 with Auxiliary Supply*



*Auxiliary Cabinet*



*Base 45 with Narc Storage*



*Supply Tower*

Contact a Metro representative to learn more:

**1.800.992.1776**





Metro provides solutions with the right technology, power, & storage to meet all your application needs from the pharmacy to the point-of-care.

# Security. Reliab

Medication & Transfer Carts

Computerized Medication Carts

Fixtures

Wall Cabinets

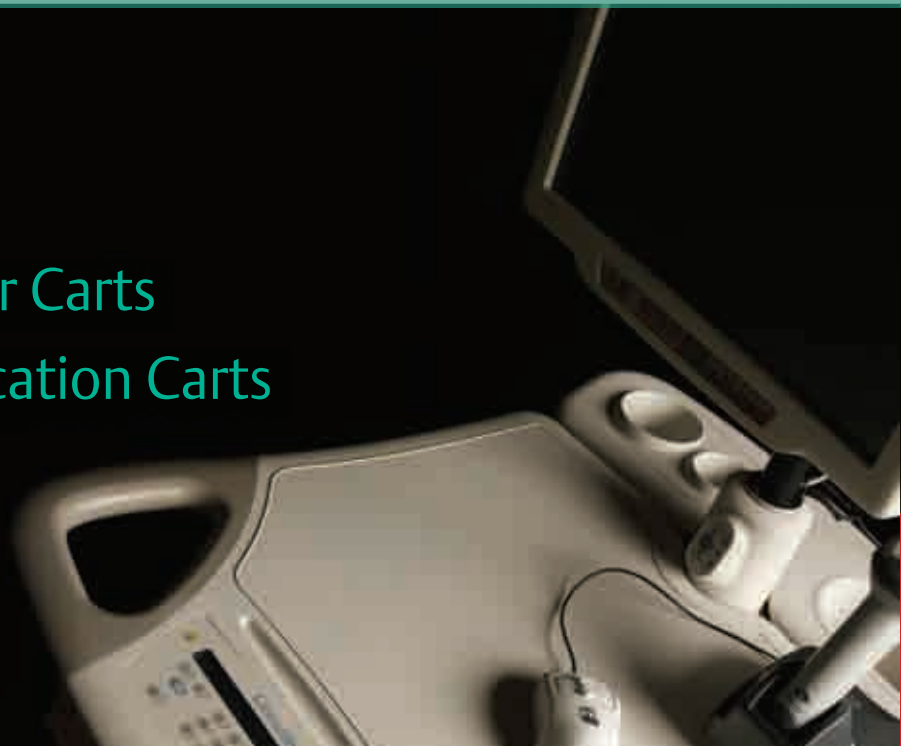



# Ability. Efficiency.

Metro offers fixtures, wall cabinets and mobile solutions for delivery of medications in acute-care and long-term-care environments. Wherever medications are stored, dispensed, administered and recorded, Metro's medication management solutions cover every step of the distribution process.

Our products are designed to support pharmacists, nurses and technology professionals, while at the same time promoting patient care.

Contact a Metro representative  
to learn more:

**1.800.992.1776**



# Solutions for a more efficient healthcare environment.

## Medication & Transfer Carts

Our complete line of Metro Lionville Series medication and transfer carts are built with nurse-friendly features developed to save time and enhance performance. Metro's 400, 600, 800 line of medication carts are designed for visual appeal without compromising function and quality. Our transfer solutions are packed with functionality. The two-sided configuration provides easily accessible storage of exchange cassettes while compact cart body and wide wheelbase help to prevent tipping. Lower height carts provide personnel with good visibility during transport - virtually eliminating any blind spots.



800



600



400



Transfer Cart

## Wall Cabinets

The Metro Lionville Series of medication management products includes a range of compact wall cabinets that can be used to store meds, supplies and computers in or near patient rooms. Wall cabinets offer an ideal compliment to a facility's mobile computing capabilities and a convenient place to securely store patient medication

**FEATURES:**

- Keyless pushbutton or key lock entry
- Interior light and adjustable shelves
- Sturdy desk door with pneumatic-assist door opening and laptop security plate
- Mini-safe for narcotics and patient valuables



*Pass-thru*



*Wall Mount with work surface*

## Computerized Medication

The Lionville Series i800 & i600 medication carts provide a wide assortment of drawer configurations and an extensive range of accessories that can be customized to meet the current and future storage and medication management requirements of any nursing unit. Configured to combine the security features of a full size medication cart with the time-saving efficiency of mobile computing, the Lionville Series i800 & i600 delivers.



*i800*



*i600*

**FEATURES:**

- Integrated power supply with cart top LED battery status indicators
- Keypad or card reader unlocking and an automatic relocking security
- Multiple drawer arrangements with a secure technology compartment
- Accommodates various pharmacy distribution methods, such as cassette exchange, robot filled envelopes or direct drawer fill
- Barcode medication administration (BCMA) support
- Access to facility's clinical information systems
- Electronic medical record (EMR) integration

Contact a Metro representative to learn more:  
**1.800.992.1776**



Lionville Fixtures...

# Helping you gain control of your pharmacy.

Sharing years of industry-leading medication management expertise, Metro's Lionville fixtures offer turnkey pharmacy storage solutions that are specifically designed for every area of your pharmacy. Lionville fixtures meet your storage needs and maximize efficiency for unit dose, order entry, sterile prep, and many other important areas throughout your facility. In addition, our planning consultants offer design expertise and a full understanding of how to make your pharmacy's workflow run more efficiently.



## Expert consultation

Metro's pharmacy experts will be there to guide you through every step of the process, from planning and design to installation.



## A perfect solution

From configuration options to quality materials, Metro has the solution you need.



“Metro has earned my confidence. They were with me every step of the way as we created a new pharmacy environment together.”

Contact a Metro representative to learn more:

**1.800.992.1776**



**Built for your needs**

We analyze your pharmacy workflow requirements in order to ensure efficiency.



**Expertly installed**

Our professionals will be there until the fitting of the final shelf, guaranteeing a smooth installation and an attractive final product.



## Adaptive Picking

Our work stations can be easily reconfigured on site to accommodate any distribution method, including unit dose distribution, decentralized automatic dispensing systems, centralized robotic filling or any future distribution technology.

# Attractive



## Seamless Order Entry

Metro's order entry and computer workstation designs increase functionality by providing integrated, user-friendly workstations that limit clutter and improve organization, so technicians can work more efficiently.

Contact a Metro representative to learn more:

**1.800.992.1776**



Drawers can be customized for a variety of supplies using durable, configurable dividers. The drawers are also designed to pull out entirely, making supplies in the rear easy to access and reconfiguring your work station simple.



Configured to adapt to your specific needs, Metro can seamlessly build in additional elements to improve workflow and overall efficiency. A sink, extra order entry station, or an additional open work space are just a few of the adaptations our experts can make to customize your pharmacy design.

# all around.

## Specialized Support

Metro's Lionville pharmacy fixtures can be specialized to support all operations throughout the pharmacy. Our flexible, modular case-work will allow for future upgrades and enhancements in areas such as clean rooms, narcotic control and even bulk storage.



Designed to increase efficiency by integrating your hardware into user-friendly and uncluttered workstations

Metro's Lionville Fixtures are created from the ground up to deliver flexibility, easy configuration, exceptional strength and durability.



Contoured front edges on all shelves. The over counter shelves have integrated brackets that allow the shelf to be placed in two gravity feed positions or flat.



All shelves have a flat retainer that slips into the front slot.

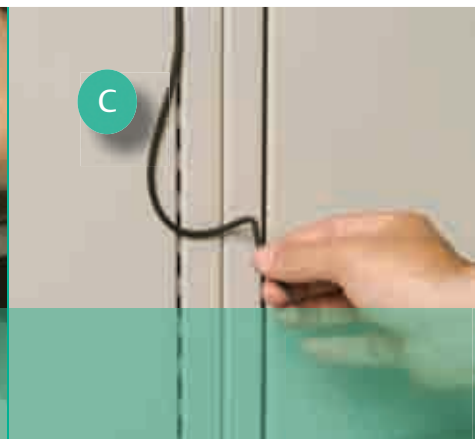

Fully slotted back panels maximize adjustability. Decorative tubing can be added to give a finished look.



Contact a Metro representative to learn more:  
**1.800.992.1776**

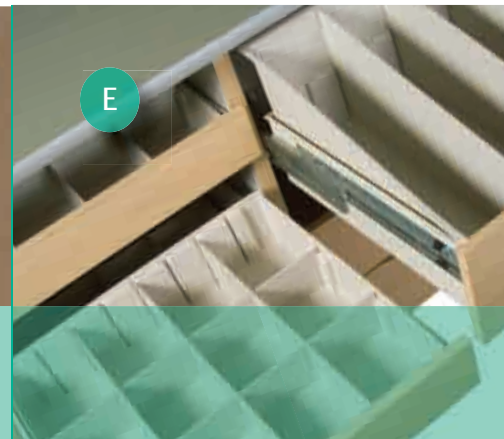

Designed with precision, the components are not only efficient, but also create a “built-in” attractive work environment. From the designer drawer pulls to the many laminate choices for wood components, our staff will help you select the combination that fits you best.

Easy exchange, easy clean drawer totes drop into drawer frames. Adjustable dividers keep supplies organized and easily identified.





Protect your investment with our Enhanced Service Program,

# Metro ESP<sup>SM</sup>



Design & Layout

Deployment Services

Preventive Maintenance

Metro is with you every step of the way... all throughout the life cycle of our products.

## Metro<sup>®</sup> Advance

### Time is money...

Metro has created a seamless process designed to get you up and running as quickly as possible. Certified technicians and professional support ensure proper installation of all your critical components and training of your staff.







## Metro<sup>®</sup> Maintain

### Free up your valuable resources and get proactive...

Preventive maintenance is a critical step to enhanced efficiency, and Metro helps you think ahead. Timed inspections by our trained and certified technicians will help lower your total cost of ownership and maximize the life of your investment.



# Fast, responsive, courteous service — with the knowledge and expertise that only Metro can provide.

	 Integration/ Deployment <b>Metro® Advance</b>	 Preventive Maintenance <b>Metro® Maintain</b>	 Ongoing Support <b>Metro® Care</b>	 Extended Warranty <b>Metro® Assurance</b>
Point of Care Computing	○	○		○
Automated Dispensing	○		○	
Healthcare Carts	○	○		○
Medication Carts	○	○		○



**Metro® Care**



**Your focus should be on your patients, not your software...** Premium access to our technical support resources provides you with the peace-of-mind that your systems will continually be updated with the latest bug fixes and patches. It's an unbeatable advantage.

**Metro® Assurance**



**Protect your investment and keep clinicians efficient...** Safeguard your equipment against unplanned downtime. Extended warranty options and rapid response from Metro help increase system reliability and keep operating costs under control.



# ENCLOSED STORAGE, TRANSPORT SYSTEMS & WORK STATIONS

Overview.....	140
Cart Overview .....	141
Procedure Carts — Modular .....	142-150
Supply Units/Carts/Cabinets & Accessories .....	151-159
Mobile WorkCenters .....	160-161
Stationary WorkCenters & Accessories .....	162-166
Overhead Units & Accessories.....	167-169
Specialty Units/Storage & Accessories .....	170-172

# Starsys — Refreshed and Refined

## Advanced security, better ergonomics and a clean new design.



# STARSYS™



Carts

Tall Units

Mobile WorkCenters

WorkCenters

Overheads

### The Starsys Modular System creates flexible space.

No matter what you need — open, closed, short, tall, mobile, stationary elements, preconfigured WorkCenters or carts . . . Starsys has the elements for you.

With Starsys, you choose from an array of modular units to fit the space and work specifications. It's that easy and that flexible.

### Starsys Benefits:

- Flexibility to design a storage solution to meet your needs.
- Corrosion-proof polymer components for a contamination-free product.
- Microban® antimicrobial protection inhibits the growth of stain and odor-causing bacteria on Starsys, keeping the surface areas “cleaner between cleanings.”
- Facilitates fast, efficient product installation.
- The ability to reconfigure unit design.
- The ability to easily reconfigure your furniture layout as needs change.
- Durable, easy-to-clean, polymer enclosures that won't chip, dent or rust ever.
- Rigid aluminum and epoxy-coated metal substructure combined with advanced polymers provides a robust stable work environment for even the most sensitive equipment.
- A high level of organization with easy access to supplies.
- Greater storage density in a smaller footprint.

Starsys Carts are built to exact customer specifications, therefore, they are non-cancelable, non-returnable.

# STARSYS™



Microban® antimicrobial protection inhibits the growth of stain and odor-causing bacteria on Starsys, keeping the surface areas “cleaner between cleanings.”

Easy to clean advanced polymer material is a marked improvement over traditional metal carts: won't dent, chip, rust, flake or corrode.

Interchangeable 3", 6" and 9" (76, 152 and 230mm) drawers with removable totes can be fully extended for easy access.

Color-coded drawer pulls are available in an array of choices to fit any system or decor.

Label holders available to quickly identify drawer contents.

Each drawer face has a 1/2 x 18 3/8" polished area allowing for secure adhesion of DYMO and Zebra labels (not supplied by Metro).

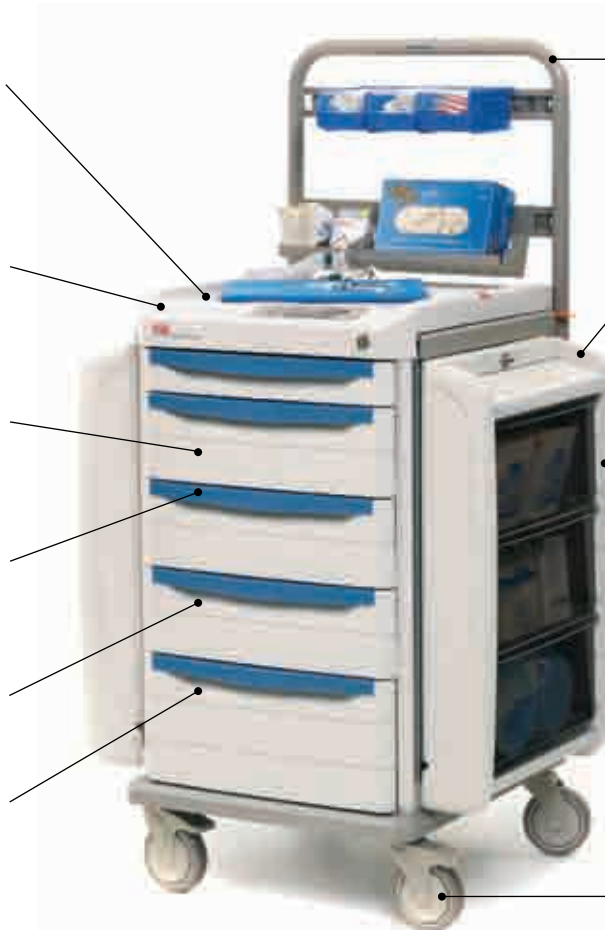

The convenient overbridge can be fitted with a wide selection of baskets, shelves, and bins to keep necessary items within reach.

Swing-out Side Storage units increase work surface up to 135%.

Side storage allows easy customization of a wide variety of accessories from trash can and Sharps container to storage bins and shelves.

5" (127mm) polyurethane casters with easily accessed toe brake make for easy rolling.



## Starsys Carts

Starsys provides a complete system of enclosed carts in a wide variety of heights and system widths. When mobility is a key part of your storage needs, Starsys carts provide a broad selection of unique solutions. This modular system approach allows you to create a cart to meet your exact needs.

### Starsys cart widths and depth:

The Starsys cart system is built upon a square module. Multiplying this storage module results in system widths of single 22 3/4" (578mm), double 42 1/2" (1080mm) and triple 62 1/2" (1588mm) widths. The depth on all carts is 24.9" (632mm).

### Starsys cart heights:

Starsys carts are available in the following working heights: 36" (907mm), 39" (983mm), 42" (1060mm), 45" (1136mm) and 48" (1212mm)

## General Overview:

Starsys carts feature 5" (127mm) polymer swivel casters. The front two casters have a Total-Lock Toe Brake (locks both the wheel and the horn).

Starsys carts feature a smooth polymer top/worksurface. If chemical resistance is a concern or heavy equipment is likely to be placed on the top of the cart, Starsys Mobile WorkCenters may be a more appropriate product selection.

An extended mobile base is required when Heavy-Duty drawers, Active Level shelving or qwikSLOT shelving is specified in a Starsys configuration. The extended mobile base adds an additional 3" (76mm) to the overall depth of the cart. The extended base combines additional counter weights with a deeper footprint to reduce any chance of overbalance when active level shelving is fully extended.

To configure a Starsys unit to your exact specifications, please visit [www.metroconfigurator.com](http://www.metroconfigurator.com)

42"

Close-up of system



General Supply with Passive Security  
Cat. No. **SXRS40CM1**



Isolation  
Cat. No. **SXRSISO**



Med Surg  
Cat. No. **SXRSMDSRG**



Dressing  
Cat. No. **SXRSDRS**

45"



Bedside Cart  
Cat. No. **SXRS43CM1**



Bedside  
Cat. No. **SXRSBED**



Computer Ready Bedside Cart  
Cat. No. **SXRCOMPBED**



Anesthesia  
Cat. No. **SXRSANES** (with key lock)  
Cat. No. **SXRSANES2** (with electronic touchpad)



Central Line Cart  
Cat. No. **SXRSCLINE**



Decentralized Medication  
Cat. No. **SXRSDCMED**



Arthroscopic  
Cat. No. **SXRSARTH**



I.V. Therapy  
Cat. No. **SXRSIV**



Unit Dose Medication  
Cat. No. **SXRSUDOSE**



Trauma  
Cat. No. **SXRSTRAMA**

Starsys Carts are built to exact customer specifications, therefore, they are non-cancelable, non-returnable.

48"



Biomedical  
Cat. No. **SXRSBIO**



Critical Care  
Cat. No. **SXRSCCU**



Cast  
Cat. No. **SXRSCAST**



Difficult Airway Cart  
Cat. No. **SXRSDIFAIR**

Basic Single Wide, Locking Carts

(in.)	(mm)	Drawer Configuration	Cat. No.
24 <sup>7</sup> / <sub>8</sub> x22 <sup>3</sup> / <sub>4</sub> x41 <sup>3</sup> / <sub>4</sub>	1061x578x1061	1-3", 3-6", 1-9", 0-12"	<b>SXRS1310L</b>
24 <sup>7</sup> / <sub>8</sub> x22 <sup>3</sup> / <sub>4</sub> x41 <sup>3</sup> / <sub>4</sub>	1061x578x1061	3-3", 2-6", 1-9", 0-12"	<b>SXRS3210L</b>
24 <sup>7</sup> / <sub>8</sub> x22 <sup>3</sup> / <sub>4</sub> x41 <sup>3</sup> / <sub>4</sub>	1061x578x1061	5-3", 1-6", 1-9", 0-12"	<b>SXRS5110L</b>
24 <sup>7</sup> / <sub>8</sub> x22 <sup>3</sup> / <sub>4</sub> x44 <sup>3</sup> / <sub>4</sub>	1137x578x1137	1-3", 2-6", 2-9", 0-12"	<b>SXRS1220L</b>
24 <sup>7</sup> / <sub>8</sub> x22 <sup>3</sup> / <sub>4</sub> x44 <sup>3</sup> / <sub>4</sub>	1137x578x1137	4-3", 2-6", 1-9", 0-12"	<b>SXRS4210L</b>
24 <sup>7</sup> / <sub>8</sub> x22 <sup>3</sup> / <sub>4</sub> x44 <sup>3</sup> / <sub>4</sub>	1137x578x1137	6-3", 1-6", 1-9", 0-12"	<b>SXRS6110L</b>
24 <sup>7</sup> / <sub>8</sub> x22 <sup>3</sup> / <sub>4</sub> x47 <sup>3</sup> / <sub>4</sub>	1213x578x1213	0-3", 3-6", 2-9", 0-12"	<b>SXRS0320L</b>
24 <sup>7</sup> / <sub>8</sub> x22 <sup>3</sup> / <sub>4</sub> x47 <sup>3</sup> / <sub>4</sub>	1213x578x1213	2-3", 2-6", 2-9", 0-12"	<b>SXRS2220L</b>
24 <sup>7</sup> / <sub>8</sub> x22 <sup>3</sup> / <sub>4</sub> x47 <sup>3</sup> / <sub>4</sub>	1213x578x1213	3-3", 3-6", 1-9", 0-12"	<b>SXRS3310L</b>

Carts shown in chart have taupe pulls.



SXRS3210L



SXRS3310L



SXRS5110L



SXRS1220L



SXRS6110L



SXRS0320L



SXRS2220L

Drawer Pulls (one required per drawer) To specify color for drawer pull, order following catalog numbers for each drawer:



Dark Taupe  
**SXRDP-TP**

White  
**SXRDP-WH**

Cobalt  
**SXRDP-CB**

Red  
**SXRDP-RE**

Orange  
**SXRDP-OR**

Green  
**SXRDP-GR**

Yellow  
**SXRDP-YL**

Slate Blue  
**SXRDP-BL**

Violet  
**SXRDP-VL**

Pink  
**SXRDP-PK**

Black  
**SXRDP-BK**

To configure a Starsys unit to your exact specifications, please visit [www.metroconfigurator.com](http://www.metroconfigurator.com)

## Build-a-Cart

### Cart Bodies without Drawers



Width/Length/Height (in.)		Width/Length/Height (mm)	Drawer Space (in. (mm))		Lock	Battery	Keyboard Mount	Width	Cat. No.	
24 <sup>7</sup> / <sub>8</sub>	22 <sup>3</sup> / <sub>4</sub>	4x37 <sup>3</sup> / <sub>4</sub>	630x577x958	24	610	Key Lock	Li-Nano	Keyboard Tray	Single	<b>SXRS27K-KL</b>
24 <sup>7</sup> / <sub>8</sub>	22 <sup>3</sup> / <sub>4</sub>	4x42 <sup>3</sup> / <sub>4</sub>	630x819x1085	27	686	Key Lock	Li-Nano	Keyboard Tray	Single	<b>SXRS30K-KL</b>
24 <sup>7</sup> / <sub>8</sub>	42 <sup>1</sup> / <sub>2</sub>	2x42 <sup>3</sup> / <sub>4</sub>	630x1080x1085	27	686	Key Lock	Li-Nano	Keyboard Tray	Double	<b>SXRD30K-KL</b>

\*Powered carts support all-in-one computers.

\*\*Powered cart shells come with a keyboard tray. Note: Keyboard inside tray dimensions: 13<sup>5</sup>/<sub>8</sub>" (346mm) W x 16<sup>3</sup>/<sub>8</sub>" (417mm) L.

### Drawers

Description	Cat. No.
3" (76mm) Drawer (No Drawer Pull)	<b>SXRS3*</b>
6" (152mm) Drawer (No Drawer Pull)	<b>SXRS6*</b>
9" (229mm) Drawer (No Drawer Pull)	<b>SXRS9*</b>
12" (305mm) Drawer (No Drawer Pull)	<b>SXRS12*</b>

\*Starsys standard drawer pull colors available.

\*\*For cassette options please refer to the Starsys cassette catalog page.



SXFLKBRDA

### Power Converters

Description	Cat. No.
Power Converter (12V Output)	<b>SXRCNVTR-12</b>
Power Converter (19V Output)	<b>SXRCNVTR-19</b>
Power Converter (24V Output)	<b>SXRCNVTR-24</b>

### Power Cord

Description	Cat. No.
Starsys/Flexline 8' (2.4m) Power Cord — US	<b>SXFL-CORD-B</b>
Starsys/Flexline 8' (2.4m) Power Cord — Euro	<b>SXFL-CORD-C</b>
Starsys/Flexline 8' (2.4m) Power Cord — UK	<b>SXFL-CORD-G</b>
Starsys/Flexline 8' (2.4m) Power Cord — Swiss	<b>SXFL-CORD-J</b>
Starsys/Flexline 8' (2.4m) Power Cord — Aus	<b>SXFL-CORD-I</b>



SXRS505

### Power Tip Kits

Description	Cat. No.
DC Power Cable, 5.5mmx2.5mmx5.5mmx2.1mmx42" Long	<b>SXFL-TIP-01</b>
DC Power Cable, 5.5mmx2.5mmx5.5mmx2.5mmx42" Long	<b>SXFL-TIP-02</b>
DC Power Cable, 5.5mmx2.5mmx4.65mmx1.65mmx42" Long	<b>SXFL-TIP-03</b>
DC Power Cable, 5.5mmx2.5mmx7.9mmx5.5.4mmx42" Long	<b>SXFL-TIP-04</b>
DC Power Cable with Center Pin, 5.5mmx2.5mmx7.4mmx5mmx42" Long	<b>SXFL-TIP-05</b>
DC Power Cable, 5.5mmx2.5mmx4.65mmx1.65mmx42" Long	<b>SXFL-TIP-06</b>

### Computer and Computer Accessories

Description	Cat. No.
Hub, 4 Port, Belkin — Black	<b>SXFLUSBHUB</b>
Mouse, Optical, USB	<b>SXFLMOUSEUSB</b>
Keyboard, IRocks Ultra X-Slim	<b>SXFLKBRDA</b>
Cover, Keyboard, IROCKS Antimicrobial	<b>SXFLKBRDACVR</b>
Tangent Vita 2001SA All-in-One Computer	<b>SXRAIO</b>



SXR319

### Computer Mounting Options

Description	Cat. No.
Monitor Arm Mounting (16-26 lbs.)	<b>SXR319</b>
Single Wide Overbridge Computer/Monitor Mounting Kit (Overbridge, Rail, Bracket & Cord Holder)	<b>SXRS505</b>
Double Wide Overbridge Computer/Monitor Mounting Kit (Overbridge, Rail, Bracket & Cord Holder)	<b>SXRD505</b>



Starsys™ Carts with Power and Technology provides clinicians with real time access to information with the added benefits of:

- Smaller footprint for tighter spaces and easier maneuvering
- Highly configurable drawers and medication bins
- Built in Microban® antimicrobial product protection

Starsys Carts are built to exact customer specifications, therefore, they are non-cancelable, non-returnable.

Packages include carts and accessories.



Computerized Bedside Package  
Cat. No. **SXRSBED-KL**



Computerized Emergency Department Package  
Cat. No. **SXRSED-KL**

Accessories

Cat. No.	Description	SXRSBED-KL	SXRSED-KL
<b>SXRTTP-001</b>	Lock Alert Touchpad Single Bay Lock	X	X
<b>SXR3DIV</b>	3" DRAWER DIVIDER KIT	2	2
<b>SXR6DIV</b>	6" DRAWER DIVIDER KIT	1	1
<b>SXRPODSLK1</b>	Left Swingout Side Pod with Top-Locking Tilt Bins		X
<b>SXRPODSLK3</b>	Left Swingout Side Pod with 3 Top-Locking Tilt Bins	X	
<b>FL236</b>	Single Glove Box Holder 20 GA.		X
<b>SXRBSKT-H</b>	WASTE BASKET WITH HOLDER		X
<b>SXRSHRPS</b>	SHARPS CONTAINER HOLDER		X
<b>SXR205</b>	Side Accessory Bracket		2
<b>SXR319</b>	Monitor Arm Mounting (16-26 lbs.)	X	X

Computer Accessories

Cat. No.	Description	SXRSBED-KL	SXRSED-KL
<b>SXRAIO</b>	Tangent Vita 2000SA All-in-One Computer	X	X
<b>SXRCNVTR-19</b>	Power Converter (19V Output)	X	X
<b>SXFL-TIP-01</b>	Power Tip Kit, 5.5mm x 2.5mm x 5.5mm x 2.1mm x 42" Long	X	X
<b>SXFL-CORD-B</b>	US Power Cord	X	X
<b>SXFLKBRDA</b>	Keyboard, IRocks Ultra X-Slim	X	X
<b>SXFLKBRDACVR</b>	Cover, Keyboard, IRocks, Antimicrobial	X	X
<b>SXFLMOUSEUSB</b>	Mouse, Optical, USB	X	X

Carts

Cat. No.	Description	SXRSBED-KL	SXRSED-KL
<b>SXRS27K-KL</b>	Starsys 40" (mm) Single Wide Cart, Key Lock, Keyboard Tray and Li-Nano Power		
<b>SXRS30K-KL</b>	Starsys 43" (mm) Single Wide Cart, Key Lock, Keyboard Tray and Li-Nano Power	X	X
<b>SXR-</b>	Drawer Pull Color	SXRDP-BL	SXRDP-BL

Drawers

Cat. No.	Description	SXRSBED-KL	SXRSED-KL
<b>SXRS3</b>	3" FL Drawer - No Drawer Pull	2	2
<b>SXRS6</b>	6" FL Drawer - No Drawer Pull	2	2
<b>SXRS9</b>	9" FL Drawer - No Drawer Pull	1	1

To configure a Starsys unit to your exact specifications, please visit [www.metroconfigurator.com](http://www.metroconfigurator.com)



M300 Series Lock

### Mechanical Keylocks

The new M300 Series Keylocks have an "Ignition-Style" design to protect keys from bending or breaking. Mechanical keylocks are a good choice for all kinds of applications and work on all types of units and accessories — carts, cabinets, drawers, doors and wall cabinets. They are available as primary locks or as backups for other types of locking systems. Each lock includes a set of two keys. Extra keys available upon request.

### Electronic Touchpad Locking System

Our most advanced full-feature keyless electronic drawer locking system designed for use on single-, double- and triple-wide carts in heights from 36" to 48" tall.

Features:

- 2,000 User/Supervisor Codes
- Auto-relock with Motion Sensors
- Proximity & Magnetic Card Reader Options
- User Management/Audit Trail Software option
- Multiple Bay Security



Electronic Touchpad Locking System

### Electronic Touchpads & Options

Description	Cat. No.
Keyless Entry Touchpad-Single Bay Locking	<b>SXRTP-varies</b>
Keyless Entry Touchpad-Double Bay Locking	<b>SXRTP-varies</b>
Keyless Entry Touchpad-Triple Bay Locking	<b>SXRTP-111</b>
User Management/Audit Trail Software	<b>FL421</b>
Charger/Voltage Adapter (for outside N. America)	<b>SXR-INTLCHGR</b>
Proximity Reader	<b>SXR-PROXRDR*</b>
Proximity User Card	<b>SXR-UPROXCRD</b>
Proximity Tag	<b>SXR-PROXTAG</b>
Magstripe Reader	<b>SXR-MAGRDR*</b>

\*Readers may not be compatible with all cards. A sample card must be submitted to verify compatibility. Contact your Metro representative.



Tamper-Evident Locks

### Tamper-Evident (Passive Security) Locks

Provides passive security for each drawer individually. Quick visual confirmation of broken seals indicates which drawers have been opened. Includes factory-installed lockbar, drawer locktabs permanently riveted to each drawer, and 100 security seals.

Description	Cat. No.
24" (610mm) Security Bar, Drawer Tabs & Seals	<b>SXRPSLK-24</b>
27" (686mm) Security Bar, Drawer Tabs & Seals	<b>SXRPSLK-27</b>
30" (762mm) Security Bar, Drawer Tabs & Seals	<b>SXRPSLK-30</b>
33" (839mm) Security Bar, Drawer Tabs & Seals	<b>SXRPSLK-33</b>
36" (914mm) Security Bar, Drawer Tabs & Seals	<b>SXRPSLK-36</b>



Hinged Lockbar

### Starsys Carts — Security Options

#### Hinged Push-Button Lockbars

These versatile push button lockbars can be used to lock both drawers and doors. Because the push button mechanism is purely mechanical, no wiring, electronic or batteries are required. Each lockbar includes a backup M300 series keylock, 2 keys, and a passive security locktab (security seals ordered separately: LEC320 = Bag of 100).

For Factory-Assembled Units

Description	Left Mounted Cat. No.	Right Mounted Cat. No.
24"H (610mm) Hinged Lockbar	<b>SXRPBL24L</b>	<b>SXRPBL24R</b>
27"H (686mm) Hinged Lockbar	<b>SXRPBL27L</b>	<b>SXRPBL27R</b>
30"H (762mm) Hinged Lockbar	<b>SXRPBL30L</b>	<b>SXRPBL30R</b>
33"H (839mm) Hinged Lockbar	<b>SXRPBL33L</b>	<b>SXRPBL33R</b>
36"H (914mm) Hinged Lockbar	<b>SXRPBL36L</b>	<b>SXRPBL36R</b>

For field retrofit of above key locking bars, add suffix **-KD** to above part numbers.

Starsys Carts are built to exact customer specifications, therefore, they are non-cancelable, non-returnable.



Polymer Drawers and Accessories

Description	Inside Dimensions (Height/Width/Length) (in.)	Non-Locking Cat. No.	Locking Cat. No.
<b>Polymer Drawers (Drawer pull required – see selection below)</b>			
3" (76mm) SW Drawer	2 <sup>3</sup> / <sub>8</sub> x16 <sup>3</sup> / <sub>8</sub> x15 <sup>7</sup> / <sub>8</sub>	<b>SXRS3</b>	<b>SXRS3-LK</b>
4.5" (114mm) SW Drawer	37/8x16 <sup>3</sup> / <sub>8</sub> x15 <sup>7</sup> / <sub>8</sub>	<b>SXRS4.5</b>	
6" (152mm) SW Drawer	5 <sup>3</sup> / <sub>8</sub> x16 <sup>1</sup> / <sub>4</sub> x15 <sup>3</sup> / <sub>4</sub>	<b>SXRS6</b>	<b>SXRS6-LK</b>
7.5" (191mm) SW Drawer	6 <sup>7</sup> / <sub>8</sub> x16 <sup>1</sup> / <sub>4</sub> x15 <sup>3</sup> / <sub>4</sub>	<b>SXRS7.5</b>	
9" (230mm) SW Drawer	8 <sup>3</sup> / <sub>8</sub> x16 <sup>1</sup> / <sub>4</sub> x15 <sup>3</sup> / <sub>4</sub>	<b>SXRS9</b>	<b>SXRS9-LK</b>
10.5" (267mm) SW Drawer	9 <sup>7</sup> / <sub>8</sub> x16 <sup>1</sup> / <sub>4</sub> x15 <sup>3</sup> / <sub>4</sub>	<b>SXRS10.5</b>	
12" (305mm) SW Drawer	11 <sup>3</sup> / <sub>8</sub> x16 <sup>1</sup> / <sub>4</sub> x15 <sup>3</sup> / <sub>4</sub>	<b>SXRS12</b>	



Removable drawer totes allow for exchange or convenient access outside of cart

Drawer Pulls (one required per drawer) To specify color for drawer pull, order following catalog numbers for each drawer:

Dark Taupe <b>SXRDP-TP</b>	White <b>SXRDP-WH</b>	Cobalt <b>SXRDP-CB</b>	Red <b>SXRDP-RE</b>	Orange <b>SXRDP-OR</b>	Green <b>SXRDP-GR</b>	Yellow <b>SXRDP-YL</b>	Slate Blue <b>SXRDP-BL</b>	Violet <b>SXRDP-VL</b>	Pink <b>SXRDP-PK</b>	Black <b>SXRDP-BK</b>

Description	Dimensions Height/Length in.	Cat. No.
<b>Drawer Label Holders</b>		
Label Kits (10 Pieces Per Kit)	3/4" X 11" (19 x 279mm)	<b>SXRLABKIT</b>

**Note:** Each drawer face has a 1/2 x 18 5/8" polished area allowing for secure adhesion of DYMO and Zebra labels (not supplied by Metro).

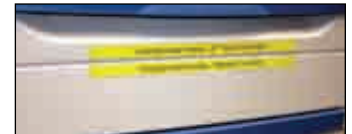

SXRLABKIT



SXR3DIV Drawer Divider Kit



SXR6DIV Drawer Divider Kit



SXR3DVR Eggcrate  
Drawer Divider Kit



DYMO and Zebra Labels  
(not supplied by Metro)

Drawer Accessories for Drawers and Full Extension Totes

Description	Product Detail (Qty.) in.	Cat. No.
<b>Drawer Divider Kits</b>		
Divider Clip to Attach Loose Short Divider-end to Long Divider, 1 per Short Divider (Qty. 2)		<b>T-CLIP</b>
3" (76mm) Drawer Divider Kit	(2) 16.8 & (6) 5	<b>SXR3DIV</b>
3" (76mm) Drawer Short Dividers	(3) 5	<b>SXR3SDIV</b>
3" (76mm) Drawer Long Dividers	(2) 16.8	<b>SXR3LDIV</b>
Egg Crate Style 3" (76mm) Drawer Divider Kit	(5) 16.8 & (10) 8	<b>SXR3DVR</b>
6" (76mm) Drawer Divider Kit	(2) 16.8 & (6) 5	<b>SXR6DIV</b>
6" (76mm) Drawer Short Dividers	(3) 5	<b>SXR6SDIV</b>
6" (76mm) Drawer Long Dividers	(2) 16.8	<b>SXR6LDIV</b>
Egg Crate Style 6"/9" (152/230mm) Drawer Divider Kit	(5) 16.8 & (10) 8	<b>SXR6DVR</b>



Drawer dividers are available to organize your supplies for easy access.

Description	Inside Dimensions (Height/Width/Length) (in.)	Inside Dimensions (Height/Width/Length) (mm)	Non-Locking Cat. No.	Locking Cat. No.
<b>Additional Starsys Totes – Totes provide complete containment for smaller items.</b>				
3" (76mm) Drawer Tote	2 <sup>3</sup> / <sub>4</sub> x18 <sup>1</sup> / <sub>4</sub> x17 <sup>1</sup> / <sub>2</sub>	70x464x445	<b>SXR3TOTE</b>	<b>SXR3-LKTOTE</b>
6" (152mm) Drawer Tote	5 <sup>3</sup> / <sub>4</sub> x18 <sup>1</sup> / <sub>4</sub> x17 <sup>1</sup> / <sub>2</sub>	146x464x445	<b>SXR6TOTE</b>	<b>SXR6-LKTOTE</b>
9" (229mm) Drawer Tote	8 <sup>1</sup> / <sub>2</sub> x18 <sup>1</sup> / <sub>4</sub> x17 <sup>1</sup> / <sub>2</sub>	216x464x445	<b>SXR9TOTE</b>	<b>SXR9-LKTOTE</b>



Drawer Totes

To configure a Starsys unit to your exact specifications, please visit [www.metroconfigurator.com](http://www.metroconfigurator.com)



Corner Accessories

Description	Dimensions	Cat. No.
Articulating Laptop Arm	Holds 1-6 lbs. Laptop Computer (Includes Arm Mounting Pole)	<b>SXLAP*</b>
Articulating LCD Monitor Arm	Holds 8.5-16.5 lbs Computer/Monitors (Includes Arm Mounting Pole)	<b>SXRMON*</b>
Articulating Tablet PC Arm	Holds 1-6 lbs. Tablet Computer (Includes Arm Mounting Pole)	<b>SXRTAB*</b>
Heavy-Duty Articulating Monitor Arm	Holds 16-26 lbs Computer/Monitors (Includes Arm Mounting Pole)	<b>SXR319*</b>
Hospital Grade Power Strip & Cord Wrap	4 Outlet Hospital Grade Power Strip & Cord Wrap	<b>SXR595</b>
I.V. Utility Pole	Attaches directly to left or right rear cart corner	<b>SXRIV</b>
Adjustable Sharps Container Bracket	Attaches to I.V. Utility Pole	<b>LEC9800</b>
Peel Pouch/Catheter Holder-18"	18" H (457mm) x 6" W (152mm) x 3" D (76mm)	<b>SXR240</b>
Peel Pouch/Catheter Holder-28"	27" H (686mm) x 6" W (152mm) x 3" D (76mm)	<b>SXR243</b>

\*Mounting pole included in part number.

SXR243



SXLAP Articulating Laptop Arm with Pole



SXRMON Articulating Monitor Arm with Pole (8.5-16.5 lbs.)



SXR319 Articulating Monitor Arm (16-26 lbs.)



Accessorized Pods on Starsys cart

Side Pods — All side pods are 30"H x 19.5"W x 6"L (762 x 483 x 152mm)

Description	Cat. No.
Fixed Side Pod (Non-Locking)	<b>SXRPOD</b>
Fixed Side Pod (with Top-Locking Tilt Bin)*	<b>SXRPODK1</b>
Fixed Side Pod (with 3-Locking Tilt Bins)**	<b>SXRPODK3</b>
Left Swing-out Side Pod (Non-Locking)	<b>SXRPODSL</b>
Left Swing-out Side Pod (with Top-Locking Tilt Bin)*	<b>SXRPODSLK1</b>
Left Swing-out Side Pod (with 3 Locking Tilt Bins)**	<b>SXRPODSLK3</b>
Right Swing-out Side Pod (Non-Locking)	<b>SXRPODSR</b>
Right Swing-out Side Pod (with Top Locking Tilt Bin)*	<b>SXRPODSRK1</b>
Right Swing-out Side Pod (with 3-Locking Tilt Bins)**	<b>SXRPODSRK3</b>

\*Top Tray with Dividers and Tilt Bin included.  
 \*\*Top Tray with Dividers and 3 Tilt Bins included.



SXRGAS



SXRPODLGE

Side Pod Accessories

Description	Dimensions — Inches (millimeters)	Cat. No.
Chart Holder	9 <sup>9</sup> / <sub>16</sub> H (242) x 11 <sup>1</sup> / <sub>2</sub> W (292) x 4 3/4L (121)	<b>SXRCHRT</b>
Containment Shelf Ledge	1 <sup>1</sup> / <sub>2</sub> H (38) 16L (406) x 3 <sup>1</sup> / <sub>2</sub> D (89)	<b>SXRPODLGE</b>
Cup Holder <sup>2</sup>	Cup Sizes: 1 <sup>3</sup> / <sub>8</sub> (35), 2 (51), 2 <sup>1</sup> / <sub>2</sub> (64)	<b>SXRCUP</b>
Gas Tank Holder <sup>3</sup>	Holds C, D and E Tanks	<b>SXRGAS-H</b>
Glove Box Holder — Single	6 <sup>1</sup> / <sub>8</sub> H (156) x 10 <sup>1</sup> / <sub>8</sub> W (258) x 4L (102)	<b>FL236</b>
Glove Box Holder — Triple	18 <sup>1</sup> / <sub>4</sub> H (464) x 10 <sup>1</sup> / <sub>8</sub> W (258) x 5 <sup>1</sup> / <sub>2</sub> L (140)	<b>FL237</b>
Lockable Sharps Container & Glove Box	18 <sup>1</sup> / <sub>4</sub> H (464) x 13W (330) x 5 <sup>1</sup> / <sub>2</sub> L (140)	<b>SXR251</b>
Lockable Sharps Replacement Containers	20/Pack, 5 Qt. (4.7L) Capacity	<b>SXRMF252</b>
Sharps Container Holder	9.3H (236) x 8W (203) x 3L (76)	<b>SXRSHRPS</b>
Tilt Out Bin	7 <sup>1</sup> / <sub>2</sub> H (191) 16L (406) x 3 <sup>1</sup> / <sub>2</sub> D (89)	<b>SXRPODBIN</b>
Top Tray (with 3 Dividers) <sup>1</sup>	2 <sup>1</sup> / <sub>2</sub> H (57) x 16 <sup>7</sup> / <sub>8</sub> W (429) x 4 <sup>3</sup> / <sub>8</sub> L (111)	<b>SXRPODTRY</b>
Waste Basket & Holder	Holder: 15.5H (394) x 8W (203) x 3L (76)	<b>SXRBSKT-H</b>
Waste Basket Only	12 <sup>1</sup> / <sub>4</sub> H (311) x 11 <sup>1</sup> / <sub>4</sub> W (286) x 8 <sup>1</sup> / <sub>4</sub> D (210)	<b>SXRBSKT</b>

<sup>1</sup>Attached to top of Unit Shelf (SXRPODHLF).  
<sup>2</sup>Attaches to top of Unit Shelf (SXRPODHLF).  
<sup>3</sup>One or two allowed on Fixed Non-Locking Pods Only.



SXRPODBIN

Starsys Carts are built to exact customer specifications, therefore, they are non-cancelable, non-returnable.

### Side Accessory Bracket

Description	Dimensions — Inches (millimeters)	Cat. No.
Side Accessory Bracket	4 <sup>3</sup> / <sub>8</sub> H (111) x 19 <sup>3</sup> / <sub>8</sub> W (492)	<b>SXR205</b>



SXR205, SXR251

### Side Accessory Bracket Accessories

Description	Dimensions — Inches (millimeters)	Cat. No.
Chart Holder <sup>1</sup>	9 <sup>7</sup> / <sub>16</sub> H (242) x 11 <sup>1</sup> / <sub>2</sub> W (292) x 4 <sup>3</sup> / <sub>4</sub> L (121)	<b>SXRCHRT</b>
Gas Tank Holder — Single <sup>2</sup>	Holds C, D and E Tanks	<b>SXRGAS-H</b>
Glove Box Holder — Single <sup>1</sup>	6 <sup>1</sup> / <sub>8</sub> H (156) x 10 <sup>1</sup> / <sub>8</sub> W (258) x 4L (102)	<b>FL236</b>
Glove Box Holder — Triple <sup>2</sup>	18 <sup>1</sup> / <sub>4</sub> H (464) x 10 <sup>1</sup> / <sub>8</sub> W (258) x 4L (102)	<b>FL237</b>
Lockable Sharps Container & Glove Box <sup>1</sup>	18 <sup>1</sup> / <sub>4</sub> H (464) x 13w (330) X 5 <sup>1</sup> / <sub>2</sub> L (140)	<b>SXR251</b>
Lockable Sharps Replacement Containers	20/Pack, 5 Qt. (4.7L) Capacity	<b>SXRMF252</b>
Scope Cabinet (2 Hooks)*	48H (1220) x 9W (229) x 6L (152)	<b>SXR245</b>
Scope Cabinet (4 Hooks)*	48H (1220) x 16W (406) x 6L (152)	<b>SXR246</b>
Sharps Container Holder <sup>1</sup>	9.3H (236) x 8W (203) x 3L (76)	<b>SXRSHRPS</b>
Side Bins (3-Pk) <sup>3</sup>	4 (102) x 4 <sup>1</sup> / <sub>2</sub> (114) x 18 <sup>3</sup> / <sub>8</sub> (254)	<b>MBP216</b>
Waste Basket & Holder <sup>1</sup>	Holder: 15.5H (394) x 8W (203) x 3L (76)	<b>SXRBSKT-H</b>
Waste Basket Only	12 <sup>1</sup> / <sub>4</sub> H (311) x 11 <sup>1</sup> / <sub>4</sub> W (286) x 8 <sup>1</sup> / <sub>4</sub> D (210)	<b>SXRBSKT</b>

\*Accessory Bracket(s) included.  
<sup>1</sup>Order with (1) SXR205 Accessory Bracket.  
<sup>2</sup>Order with (2) SXR205 Accessory Brackets.  
<sup>3</sup>Order with (3) SXR205 Accessory Brackets



SXR246

### Other Side Accessories

Description	Dimensions — Inches (millimeters)	Cat. No.
Extended Handle	4H (102) x 21 <sup>1</sup> / <sub>2</sub> W (546) x 4 <sup>1</sup> / <sub>4</sub> L (108)	<b>SXREHAN</b>
Extended Handle (Field Retrofit)	4H (102) x 21 <sup>1</sup> / <sub>2</sub> W (546) x 4 <sup>1</sup> / <sub>4</sub> L (108)	<b>SXREHAN-KD</b>
Pullout Writing Surface (Left Side)	17.5"W (445) x 15.75"L (400); (25 lb. cp.)	<b>SXRPULLOUTL</b>
Pullout Writing Surface (Right Side)	17.5"W (445) x 15.75"L (400); (25 lb. cp.)	<b>SXRPULLOUTR</b>



SXRPULLOUTL

### Overbridge and Accessories

Description	Cat. No.
(A) Single-wide Overbridge Assembly with two Hanger Rails**	<b>SXRSOB</b>
Single-Wide Overbridge with Computer/Monitor Mounting Kit	<b>SXRS505</b>
Single-wide Overbridge Assembly with no Hanger Rails	<b>SXRSOB-1000</b>
(B) Hanger Rail (2 <sup>3</sup> / <sub>16</sub> " [55mm] H.x1" [25.4mm] W.x19 <sup>1</sup> / <sub>2</sub> " [495mm] L. usable space	<b>SXROBSRAIL</b>
Single-wide Overbridge with Top Shelf and Hanger Rail	<b>SXR515</b>
Single-wide Overbridge with 2 Shelves	<b>SXR520</b>
Single-wide Overbridge Shelf (14" [286mm]x23 <sup>3</sup> / <sub>4</sub> " [590mm])***	<b>SXR560</b>
Double-wide Overbridge Assembly with two Hanger Rails** (for use on double-wide carts only)	<b>SXRDOB</b>
Double-Wide Overbridge with Computer/Monitor Mounting Kit	<b>SXRD505</b>
Double-wide Overbridge Assembly with no Hanger Rails	<b>SXRDOB-1000</b>
Double-wide Hanger Rail (2 <sup>3</sup> / <sub>16</sub> " [55mm] H.x1" [25.4mm] W.x39 <sup>1</sup> / <sub>2</sub> " [1003mm] L. usable space	<b>SXROBDRAIL</b>
Double-wide Overbridge with Top Shelf and Hanger Rail	<b>SXRD515</b>
Double-wide Overbridge with 2 Shelves	<b>SXRD520</b>
Double-wide Shelf (43 <sup>9</sup> / <sub>16</sub> " [1106mm]x10 <sup>1</sup> / <sub>4</sub> " [260mm])***	<b>SXRD560</b>
Utility Pole Including Universal Clamp (Attaches to Overbridge)	<b>SXR566</b>
Universal Clamp	<b>SXR570</b>
Short Utility Hook (package of 4) (3 <sup>1</sup> / <sub>2</sub> " [89mm] usable length)	<b>SXR571</b>
Laryngoscope Blade/Specimen Holder	<b>SXR575</b>
(C) Half-Size Metal Utility Bin (5 <sup>1</sup> / <sub>2</sub> " [140mm] H.x5 <sup>1</sup> / <sub>2</sub> " [140mm] W.x5 <sup>3</sup> / <sub>4</sub> " [146mm] L.)	<b>SXR581</b>
(D) Full-Size Metal Utility Bin (5 <sup>1</sup> / <sub>2</sub> " [140mm] H.x5 <sup>1</sup> / <sub>2</sub> " [140mm] W.x11 <sup>5</sup> / <sub>8</sub> " [292mm] L.)	<b>SXR582</b>
Label/Tape Dispenser (holds up to 2" [50mm] diameter roll with 2 <sup>3</sup> / <sub>4</sub> " [70mm] width of roll space)	<b>SXR583</b>
Wire Supply Basket (7" [178mm] H.x5" [127mm] W.x17" [432mm] L.)	<b>SXR585</b>
(E) Utility Bin with Cover (Package of 6)	<b>SXR586</b>
†Sharps Container Bracket	<b>FL584</b>
††Sharps Container Bracket — Holds containers with up to a 41" [1041mm] perimeter	<b>LEC9800</b>
Tilt Bin 3 Units with Brackets (6 <sup>3</sup> / <sub>4</sub> " [172mm] W.x8 <sup>1</sup> / <sub>8</sub> " [206mm] D.x7 <sup>1</sup> / <sub>2</sub> " [191mm] H.)	<b>SXRMF543</b>
Tilt Bin 4 Units with Brackets (5 <sup>1</sup> / <sub>16</sub> " [129mm] W.x7 <sup>1</sup> / <sub>4</sub> " [184mm] D.x6 <sup>1</sup> / <sub>2</sub> " [165mm] H.)	<b>SXRMF544</b>
Tilt Bin 6 Units with Brackets (3 <sup>1</sup> / <sub>8</sub> " [79mm] W.x3 <sup>1</sup> / <sub>2</sub> " [89mm] D.x3 <sup>1</sup> / <sub>4</sub> " [82mm] H.)	<b>SXRMF546</b>



SXREHAN

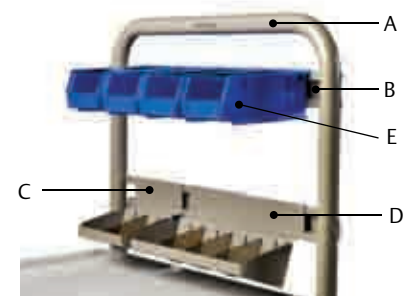

SXRSOB Overbridge Assembly (shown with optional accessories)

\*\* Maximum weight capacity for overbridge assembly is 40 lbs. (18.1kg).  
\*\*\* Maximum weight capacity for overbridge shelf is 40 lbs. (18.1kg).  
† Mounts to universal clamp in addition to hanger rail.  
†† Mounts to I.V. pole or utility pole.

To configure a Starsys unit to your exact specifications, please visit [www.metroconfigurator.com](http://www.metroconfigurator.com)



4 Level Cassette



Bins



Double-Wide, Double Sided Medication Cassette Transfer Cart  
Cat. No. SXRD46TRAN  
(shown with cassettes and bins, sold separately, see above)

Components — Polymer

Description	No. of Bins Per Level	Overall Dimensions		Cat. No.
		Height/Width/Length (in.)	Height/Width/Length (mm)	
<b>Cassettes and Bins</b>				
1 Level Cassette Body		5 <sup>15</sup> / <sub>16</sub> x11 <sup>3</sup> / <sub>4</sub> x19 <sup>3</sup> / <sub>8</sub>	151x298x492	SXRCASB1
2 Level Cassette Body		8 <sup>15</sup> / <sub>16</sub> x11 <sup>3</sup> / <sub>4</sub> x19 <sup>3</sup> / <sub>8</sub>	277x298x492	SXRCASB2
3 Level Cassette Body		11 <sup>15</sup> / <sub>16</sub> x11 <sup>3</sup> / <sub>4</sub> x19 <sup>3</sup> / <sub>8</sub>	303x298x492	SXRCASB3
4 Level Cassette Body		14 <sup>15</sup> / <sub>16</sub> x11 <sup>3</sup> / <sub>4</sub> x19 <sup>3</sup> / <sub>8</sub>	379x298x492	SXRCASB4
5 Level Cassette Body		17 <sup>15</sup> / <sub>16</sub> x11 <sup>3</sup> / <sub>4</sub> x19 <sup>3</sup> / <sub>8</sub>	456x298x492	SXRCASB5
3" (76mm) wide Cassette Bin	6	2 <sup>9</sup> / <sub>16</sub> x11 <sup>15</sup> / <sub>16</sub> x2 <sup>11</sup> / <sub>16</sub>	65x303x68	SXRBINSB3
4 <sup>1</sup> / <sub>2</sub> " (114mm) wide Cassette Bin	4	2 <sup>9</sup> / <sub>16</sub> x11 <sup>15</sup> / <sub>16</sub> x4 <sup>1</sup> / <sub>16</sub>	65x303x103	SXRBINSB4
6" (152mm) wide Cassette Bin	3	2 <sup>9</sup> / <sub>16</sub> x11 <sup>15</sup> / <sub>16</sub> x5 <sup>1</sup> / <sub>2</sub>	65x303x140	SXRBINSB6
8" (203mm) wide Cassette Bin	2	2 <sup>9</sup> / <sub>16</sub> x11 <sup>15</sup> / <sub>16</sub> x8	65x303x203	SXRBINSB8

Note: Bins are shipped with one ID card.

Description	Cat. No.
<b>Bin Accessories</b>	
Cassette Bin Divider Kit (20 dividers)	SXRBINDIV
Cassette Label Kit (includes label strips in Mauve, Slate Blue and Jade for identification of bins)	SXRCASLAB
Cassette Bin Labels (5 sheets of Slate Blue bin labels — 18 of each size per sheet)	SXRBINLAB-BL
Cassette Bin Labels (5 sheets of Jade bin labels — 18 of each size per sheet)	SXRBINLAB-GR
Cassette Bin Labels (5 sheets of Mauve bin labels — 18 of each size per sheet)	SXRBINLAB-RD

SXRBINDIV divides up to 4 bins.  
SXRCASLAB includes 3 sheets of labels. One sheet per color. Each sheet contains 18 labels for each size bin. It also includes 18 patient ID bin cards for each size bin and 4 cassette ID labels.

Medication Cassette Transfer Carts

Description	Overall Dimensions		Inside Height		Approx. Pkd. Wt.		Cat. No.
	Height/Width/Length (in.)	Height/Width/Length (mm)	(in.)	(mm)	(lbs.)	(kg)	
<b>Single-Wide, Double-Sided*</b>							
42" (1067mm) Single	41 <sup>3</sup> / <sub>4</sub> x24 <sup>7</sup> / <sub>8</sub> x22 <sup>11</sup> / <sub>16</sub>	1060x632x576	30 <sup>1</sup> / <sub>4</sub>	768	150	68	SXRS40TRAN
45" (1143mm) Single	44 <sup>3</sup> / <sub>4</sub> x24 <sup>7</sup> / <sub>8</sub> x22 <sup>11</sup> / <sub>16</sub>	1136x632x576	33 <sup>3</sup> / <sub>4</sub>	845	150	68	SXRS43TRAN
48" (1219mm) Single	47 <sup>9</sup> / <sub>4</sub> x24 <sup>7</sup> / <sub>8</sub> x22 <sup>11</sup> / <sub>16</sub>	1212x632x576	36 <sup>1</sup> / <sub>4</sub>	921	157	71	SXRS46TRAN
<b>Double-Wide, Double Sided*</b>							
42" (1067mm) Double	41 <sup>3</sup> / <sub>4</sub> x24 <sup>7</sup> / <sub>8</sub> x42 <sup>1</sup> / <sub>2</sub>	1060x632x1080	30 <sup>1</sup> / <sub>4</sub>	768	170	77	SXRD40TRAN
45" (1143mm) Double	44 <sup>3</sup> / <sub>4</sub> x24 <sup>7</sup> / <sub>8</sub> x42 <sup>1</sup> / <sub>2</sub>	1136x632x1080	33 <sup>3</sup> / <sub>4</sub>	845	176	80	SXRD43TRAN
48" (1219mm) Double	47 <sup>9</sup> / <sub>4</sub> x24 <sup>7</sup> / <sub>8</sub> x42 <sup>1</sup> / <sub>2</sub>	1212x632x1080	36 <sup>1</sup> / <sub>4</sub>	921	181	82	SXRD46TRAN

\*Cassette storage available on both front and back of cart.

Starsys™ Single Bin Access Cassette System

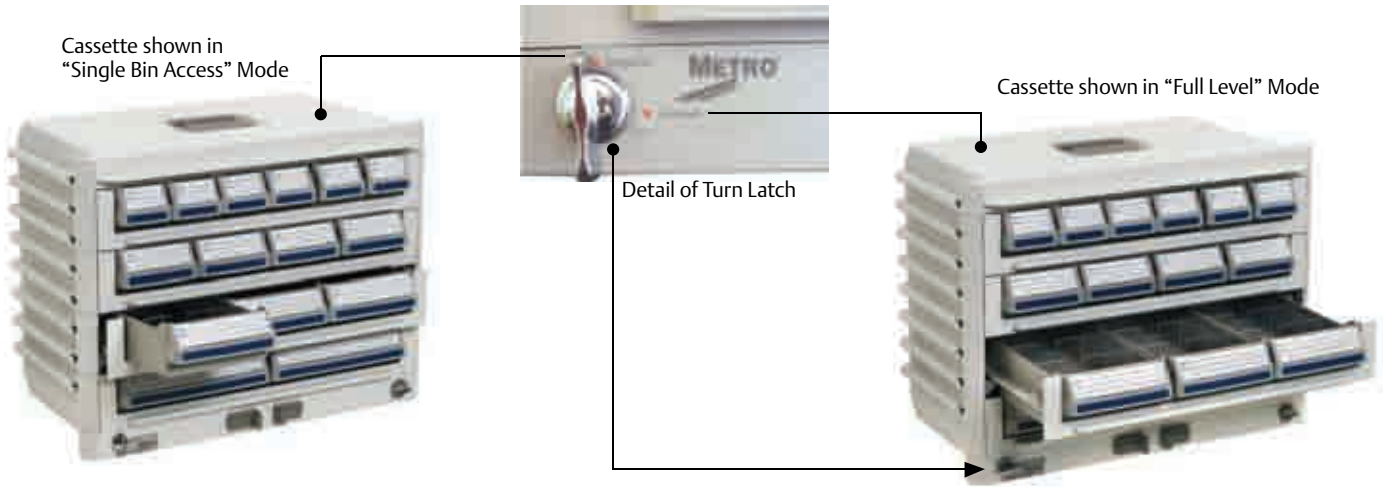

Starsys Carts are built to exact customer specifications, therefore, they are non-cancelable, non-returnable.

# STARSYS™



Mobile Units are stand-alone products. Mobile units are available in single (22<sup>3</sup>/<sub>4</sub>" [578mm]), double (42<sup>1</sup>/<sub>2</sub>" [1080mm]) and triple (62<sup>1</sup>/<sub>2</sub>" [1558mm]) widths. The overall height of a tall mobile unit is 78<sup>1</sup>/<sub>3</sub>" (1990mm). Add 11<sup>3</sup>/<sub>4</sub>" (299mm) with sloped tops. All units are 24<sup>7</sup>/<sub>8</sub>" (632mm) deep.

General Overview:

The configurable interior space is 66" (1676mm) on a tall unit. Short units interior space from 24" (610mm) to 48" (1219mm) in 3" (76mm) increments.

Triple-width units must be divided into a single & double bay or three single bays — there are no triple wide accessories.

The specification of a quikSLOT interior or an empty interior will necessitate an extended mobile base as part of the configuration.

Starsys Mobile Units have a total recommended load rating of 900 lbs. (408kg) including the weight of the Starsys unit.

Units feature two 5" (127mm) casters — the front two casters have color-matched toe-brakes.

Microban® antimicrobial protection inhibits the growth of stain and odor-causing bacteria on Starsys, keeping the surface areas “cleaner between cleanings.”

Tall Stationary Units are stand-alone products or may be used in conjunction with other tall units or Starsys product families. Tall stationary units are available in single and double widths only.

General Overview:

The overall height of a tall stationary unit is 72<sup>1</sup>/<sub>2</sub>" (1842mm). Add 11<sup>3</sup>/<sub>4</sub>" (299mm) with sloped tops. Overall widths are 21<sup>1</sup>/<sub>2</sub>" (546mm) for singles and 41<sup>1</sup>/<sub>3</sub>" (1049mm) for doubles.

The configurable interior space is 66" (1676mm).

Filler kits are available to fill gaps between units, between the back of a unit and the wall (25" [635mm] & 30" [762mm] depths) and between tall units interfacing at 45 or 90 degrees.

All tall units must be affixed to the wall with appropriate mounting hardware utilizing the attached Starsys mounting bracket or affixed to the floor with the optional floor mounting kit.

Tall units are not intended to support cantilevered countertop sections.

To configure a Starsys unit to your exact specifications, please visit [www.metroconfigurator.com](http://www.metroconfigurator.com)



Cat. No. **SXRD43CM3**



Cat. No. **SXRD43CM4**  
(2) Wire shelves,  
non-locking doors



Cat. No. **SXRSGS1**  
(3) Poly shelves,  
non-locking door



Cat. No. **SXRSGS2**



Cat. No. **SXRS76CM5**  
(4) Wire shelves,  
non-locking door



Cat. No. **SXRS76CMHD2**



Cat. No. **SXRDGS1**



Cat. No. **SXRD76CM3**  
(4) Wire shelves,  
non-locking door



Cat. No. **SXRTGS2**  
(6) Poly shelves behind upper doors,  
(5) Wire shelves right bay, non-locking doors



Cat. No. **SXRTGS3**  
(7) Double-side wire shelves in left bay,  
(5) single-wide wire shelves in right bay  
non-locking doors

**Note:**  
See pages 170-172  
for specialty carts  
and accessories  
(i.e. catheter, suture,  
I.V., instrument).



Extended Handle

Accessories

Description	Cat. No.
Extended Handle Assembly 4" ([102mm] H.x21½" [546mm] W.x 4¼" [108mm] L.)	<b>SXREHAN</b>
Extended Handle Assembly — KD	<b>SXREHAN-KD</b>

StarSys Carts are built to exact customer specifications, therefore, they are non-cancelable, non-returnable.



Cat. No. **SXRS72TU2**



Cat. No. **SXRS72TU3**



Cat. No. **SXRS72TU4**



Cat. No. **SXRD72TU2**  
Poly shelves, locking doors



Cat. No. **SXRD72TU3**  
(2) Poly shelves in left bay, (5) wire shelves in right bay, non-locking doors



Cat. No. **SXRD72TU5**  
(5) Wire shelves, non-locking doors



Cat. No. **SXRD72TU6**  
(5) Wire shelves, locking doors



Cat. No. **SXRD72SCATH2**  
(2) Poly shelves, non-locking door (left), locking door (right)



To configure a Starsys unit to your exact specifications, please visit [www.metroconfigurator.com](http://www.metroconfigurator.com)

Full Depth Units



General Supply  
Cat. No. **SXRS80SGSTD**



Catheter Storage  
Cat. No. **SXRS80SCATHTD**



Catheter Storage  
Cat. No. **SXRS83MCATHTD**



General Supply  
Cat. No. **SXRD80SGSTD**



General Supply  
Cat. No. **SXRD83MGSTD**



Catheter Storage  
Cat. No. **SXRD83MCATHTD**

Half Depth Units



General Supply  
Cat. No. **SXRS80HGSTD**



Catheter Storage  
Cat. No. **SXRS80HCATHTD**



General Supply  
Cat. No. **SXRD80HGSTD**



Catheter Storage  
Cat. No. **SXRD80HCATHTD**

Starsys Carts are built to exact customer specifications, therefore, they are non-cancelable, non-returnable.



## Half-Depth Catheter Storage

Cat. No.	Description	(in.)	Overall		Interior	
			(mm)	(mm)	(in.)	(mm)
<b>Stationary Only</b>						
<b>SXRS80HCATHTD</b>	Single Wide Stationary Unit with (1) Catheter Shelf, (3) Slides, (15) Hooks, (1) Poly Shelf	21.5x80x18	546x2032x457	15.5	394	
<b>SXRD80HCATHTD</b>	Double Wide Stationary Unit with (2) Catheter Shelves, (6) Slides, (30) Hooks, (2) Poly Shelves	41.4x80x18	1052x2032x457	15.5	394	

## Full-Depth Catheter Storage

Cat. No.	Description	(in.)	Overall		Interior	
			(mm)	(mm)	(in.)	(mm)
<b>Stationary</b>						
<b>SXRS80SCATHTD</b>	Single Wide Stationary Unit with (1) Catheter Shelf, (3) Slides, (15) Hooks, (1) Poly Shelf	21.5x80x25.5	546x2032x648	23	584	
<b>SXRD80SCATHTD</b>	Double Wide Stationary Unit with (2) Catheter Shelves, (6) Slides, (30) Hooks, (2) Poly Shelves	41.4x80x25.5	1052x2032x648	23	584	
<b>Mobile</b>						
<b>SXRS83MCATHTD</b>	Single Wide Mobile Unit with (1) Catheter Shelf, (3) Slides, (15) Hooks, (1) Poly Shelf	21.5x83x27.8	546x2108x706	23	584	
<b>SXRD83MCATHTD</b>	Double Wide Mobile Unit with (2) Catheter Shelves, (6) Slides, (30) Hooks, (2) Poly Shelves	42.5x83x27.8	1080x2108x706	23	584	

## Half-Depth General Supply

Cat. No.	Description	(in.)	Overall		Interior	
			(mm)	(mm)	(in.)	(mm)
<b>Stationary Only</b>						
<b>SXRS80HGSTD</b>	Single Wide Stationary Unit with (4) Taupe Powder Coated Wire Shelves	21.5x80x18	546x2032x457	15.5	394	
<b>SXRD80HGSTD</b>	Double Wide Stationary Unit with (4) Taupe Powder Coated Wire Shelves	41.4x80x18	1052x2032x457	15.5	394	

## Full-Depth General Supply

Cat. No.	Description	(in.)	Overall		Interior	
			(mm)	(mm)	(in.)	(mm)
<b>Stationary</b>						
<b>SXRS80SGSTD</b>	Single Wide Stationary Unit with (4) qwikSLOT Chrome Wire Shelves	21.5x80x25.5	546x2032x648	23	584	
<b>SXRD80SGSTD</b>	Double Wide Stationary Unit with (4) qwikSLOT Chrome Wire Shelves Mobile	41.4x80x25.5	1052x2032x648	23	584	
<b>Mobile</b>						
<b>SXRS83MGSTD</b>	Single Wide Mobile Unit with (4) qwikSLOT Chrome Wire Shelves	21.5x83x27.8	546x2108x706	23	584	
<b>SXRD83MGSTD</b>	Double Wide Mobile Unit with (4) qwikSLOT Chrome Wire Shelves	42.5x83x27.8	1080x2108x706	23	584	

## Back Filler Kits for Stationary Units (Recommended)

Cat. No.	Description
<b>SXRBKFLR18TD</b>	Back Filler Kit (For Tall Half Depth TD Stationary Unit with 18" Deep Base Units)
<b>SXRBKFLR25TD</b>	Back Filler Kit (For Tall Full Depth TD Stationary Unit with 25" Deep Base Units)
<b>SXRBKFLR30TD</b>	Back Filler Kit (For Tall Full Depth TD Stationary Unit with 30" Deep Base Units)

To configure a Starsys unit to your exact specifications, please visit [www.metroconfigurator.com](http://www.metroconfigurator.com)



Polymer shelves are easy to clean and reposition.

### Accessories for Units with Slotted Inner Panels

#### Polymer Shelves

Cat. No.	Description
<b>SXRPOLY</b>	Single Wide Polymer Shelf
<b>SXRPOLYDIV</b>	Poly Shelf Divider Kit (Includes 2 Divider Rails, 4 Dividers)
<b>SXRSF-VSHFDIV</b>	Single Wide Vertical Shelf Divider Kit (w/(2) brackets & (2) vertical dividers)
<b>SXRDF-VSHFDIV</b>	Double Wide Vertical Shelf Divider Kit (w/(2) brackets & (2) vertical dividers)
<b>SXRFVDIV-1</b>	Extra Vertical Shelf Divider



Catheter Storage

#### Catheter Storage

<b>SXRCATH</b>	Catheter Storage Module (Includes Catheter Shelf, (3) Slides & (15) 5"H Hooks)
<b>SXRCATH-SHF</b>	Catheter Shelf
<b>SXRCATHSLD</b>	Catheter Slide Assembly (Includes (15) 5"H Hooks)
<b>SXRCATHHK</b>	3"H Catheter Hooks (5-Pack)

#### Suture Storage

<b>SXRSUTURE</b>	Suture Storage Module
------------------	-----------------------



Suture Storage

#### Full-Extension Totes

<b>SXRFTOT3</b>	3" Full Extension Tote/Frame Assembly
<b>SXRFTOT6</b>	6" Full Extension Tote/Frame Assembly
<b>SXRFTOT9</b>	9" Full Extension Tote/Frame Assembly
<b>SXR3DIV</b>	3" Tote Divider Kit (Includes (2) Long Dividers & (6) Short Dividers)
<b>SXR3SDIV</b>	3" Short Divider Kit (3-Pack)
<b>SXR3LDIV</b>	3" Long Divider Kit (2-Pack)
<b>SXR6DIV</b>	6" Tote Divider Kit (Includes (2) Long Dividers & (6) Short Dividers)
<b>SXR6SDIV</b>	6" Short Divider Kit (3-Pack)
<b>SXR6LDIV</b>	6" Long Divider Kit (2-Pack)
<b>SXR3DVR</b>	3" Eggcrate Style Tote Divider Kit
<b>SXR6DVR</b>	6" Eggcrate Style Tote Divider Kit



Full Extension Tote and Basket

#### Full-Extension Baskets

<b>SXRFBSK3</b>	3" Full Extension Basket/Frame Assembly
<b>SXRFBSK7</b>	7.5" Full Extension Basket/Frame Assembly
<b>SXRFB3SDIV</b>	3" Short Basket Dividers (3-Pack)
<b>SXRFB3LDIV</b>	3" Long Basket Dividers (2-Pack)
<b>SXRFB7SDIV</b>	7.5" Short Basket Dividers (3-Pack)
<b>SXRFB7LDIV</b>	7.5" Long Basket Dividers (2-Pack)

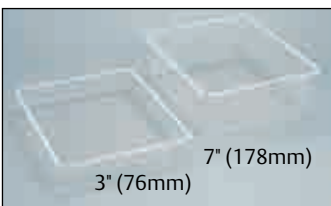

Baskets

Starsys Carts are built to exact customer specifications, therefore, they are non-cancelable, non-returnable.

Accessories for Units with qwikSLOT™ Inserts  
Wire Shelves



SXRSLDG Ledge

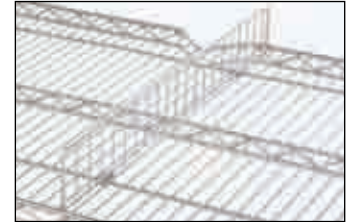

SXRSLFDIV



Stent and Graft Module



Heavy-Duty Drawer

**Note:** All HD drawers used in mobile applications require keylock modules.

Cat. No.	Description
<b>SXRSWQ</b>	Single Wide QS Wire Shelf
<b>SXRSWAR</b>	Single Wide Full Extension Wire Shelf (Right Thumb Latch)
<b>SXRSWAL</b>	Single Wide Full Extension Wire Shelf (Left Thumb Latch)
<b>SXRDWQ</b>	Double Wide QS Wire Shelf
<b>SXRDWAR</b>	Double Wide Full Extension Wire Shelf (Right Thumb Latch)
<b>SXRDWAL</b>	Double Wide Full Extension Wire Shelf (Left Thumb Latch)
<b>2148CI-4</b>	Clear Inlays for Wire Shelves (4-Pk)
<b>9990P7</b>	Label Holder for Single Wide Wire Shelf
<b>9990P8</b>	Label Holder for Double Wide Wire Shelf
<b>SXRSLDG</b>	4"H Wire Shelf Ledge
<b>SXRSLFDIV</b>	4"H Wire Shelf Divider
<b>SXRSLFDIV8</b>	8"H Wire Shelf Divider

Stent and Graft Module

<b>SXRSGM</b>	Stent and Graft Module
---------------	------------------------

Components — qwikSLOT™

All Starsys Heavy-Duty drawers have an interior front-to-back dimension of 19.188" (487mm).  
Single Heavy-Duty drawers have an interior width of 16.375" (416mm).  
Double Heavy-Duty drawers have an interior width of 36.250" (920mm).

Description	Interior Depth		Cat. No.
	(in.)	(mm)	
<b>Heavy-Duty Drawers — Single</b>			
3" (76mm) SW Starsys Heavy-Duty Drawer	2 <sup>3</sup> / <sub>8</sub>	60	<b>SXRS3HD</b>
6" (152mm) SW Starsys Heavy-Duty Drawer	5 <sup>3</sup> / <sub>8</sub>	136	<b>SXRS6HD</b>
9" (229mm) SW Starsys Heavy-Duty Drawer	8 <sup>3</sup> / <sub>8</sub>	213	<b>SXRS9HD</b>
12" (305mm) SW Starsys Heavy-Duty Drawer	11 <sup>3</sup> / <sub>8</sub>	289	<b>SXRS12HD</b>
Single-Wide Drawer Top No Lock*			<b>SXRSHDWRTOP</b>
<b>Heavy-Duty Drawers — Double</b>			
3" (76mm) DW Starsys Heavy-Duty Drawer	2 <sup>3</sup> / <sub>8</sub>	60	<b>SXRD3HD</b>
6" (152mm) DW Starsys Heavy-Duty Drawer	5 <sup>3</sup> / <sub>8</sub>	136	<b>SXRD6HD</b>
9" (229mm) DW Starsys Heavy-Duty Drawer	8 <sup>3</sup> / <sub>8</sub>	213	<b>SXRD9HD</b>
12" (305mm) DW Starsys Heavy-Duty Drawer	11 <sup>3</sup> / <sub>8</sub>	289	<b>SXRD12HD</b>
Double-Wide Drawer Top No Lock*			<b>SXRDHDWRTOP</b>

\*Used when shelf is required directly over a drawer or door.

Description	Cat. No.
<b>Heavy-Duty Drawer Dividers — Single</b>	
3" (76mm) SW Drawer Divider Kit	<b>SXRS3HDIV</b>
6" (152mm) SW Drawer Divider Kit	<b>SXRS6HDIV</b>
<b>Heavy-Duty Drawer Dividers — Double</b>	
3" (76mm) DW Drawer Divider Kit	<b>SXRD3HDIV</b>
6" (152mm) DW Drawer Divider Kit	<b>SXRD6HDIV</b>
<b>Drawer Label Kits</b>	
Label Kit	<b>SXRLABKIT</b>

Drawer Pulls (one required per drawer) To specify color for drawer pull, order following catalog numbers for each drawer:

Dark Taupe <b>SXRDP-TP</b>	White <b>SXRDP-WH</b>	Cobalt <b>SXRDP-CB</b>	Red <b>SXRDP-RE</b>	Orange <b>SXRDP-OR</b>	Green <b>SXRDP-GR</b>	Yellow <b>SXRDP-YL</b>	Slate Blue <b>SXRDP-BL</b>	Violet <b>SXRDP-VL</b>	Pink <b>SXRDP-PK</b>	Black <b>SXRDP-BK</b>

To configure a Starsys unit to your exact specifications, please visit [www.metroconfigurator.com](http://www.metroconfigurator.com)

MetroTote Accessories — 16.64



Metro Totes

Dividers

For Tote Box	Dividers	Outside Dimensions (includes lip) Length x Width x Height (in.)	Approx. Tote Box Wt. (lbs.)	Cat. No.
MTB93030W	Short <b>MDS93030NAT</b>	22 <sup>1</sup> / <sub>2</sub> x17 <sup>1</sup> / <sub>2</sub> x3	2.57	<b>MTB93030W</b>
	Long <b>MDL93030NAT</b>	572x445x76		
MTB93060W	Short <b>MDS93060NAT</b>	22 <sup>1</sup> / <sub>2</sub> x17 <sup>1</sup> / <sub>2</sub> x6	4.0	<b>MTB93060W</b>
	Long <b>MDL93060NAT</b>	572x445x152		
MTB93080W	Short <b>MDS93080NAT</b>	22 <sup>1</sup> / <sub>2</sub> x17 <sup>1</sup> / <sub>2</sub> x8	5.25	<b>MTB93080W</b>
	Long <b>MDL93080NAT</b>	572x445x203		
MTB93120W	Short <b>MDS93080NAT</b>	22 <sup>1</sup> / <sub>2</sub> x17 <sup>1</sup> / <sub>2</sub> x12	6.67	<b>MTB93120W</b>
	Long <b>MDL93080NAT</b>	572x445x305		

Stocking Bin

Cat. No.	Description
<b>MB30348T*</b>	8 <sup>1</sup> / <sub>4</sub> "W (210) x 20.5D (521) x 7H (178) Stocking Bin

\*Packed 6/ctn. — order in multiples of 6. Priced per each.

Mobile Unit Accessory

Cat. No.	Description
<b>SXREHAN-KD</b>	Extended Handle (left or right side)

Filler Kits and Trim Kits — Tall Stationary Units

Description	Cat. No.
Unit to Unit Filler Strip Kit	<b>SXR72UUFLR</b>
Back Wall Trim Kit x 72" (1829mm)	<b>SXR72BKFLR</b>
Back Wall Trim Kit x 72" (1829mm) — 30" (762mm) Deep	<b>SXR72BKFLR30</b>
45° Corner Filler Strip Kit x 84" (2134mm)	<b>SXR84CR45FLR</b>
90° Corner Filler Strip Kit x 84" (2134mm)	<b>SXR84CR90FLR</b>

Tambour Door Half-Depth Unit Accessories

Catheter Storage

Description	Cat. No.
HD Catheter Storage Module (includes Catheter Shelf, (3) Slides & (15) Hooks)	<b>SXRHCATH</b>
HD Catheter Shelf	<b>SXRHCATH-SHF</b>
HD Catheter Slide Assembly with hooks/5-pk	<b>SXRHCATHSLD</b>
HD Catheter Hooks — 5-Pk	<b>SXRCATHHK</b>
HD Fixed Catheter Storage Assy (includes(1) Hook Rail & (3) Hooks with Labels	<b>SXRFXCATH</b>
HD Fixed Catheter Storage Assy Hooks/5-pk	<b>SXRFCAT-HK-3</b>

Hanging Totes

HD 3" Hanging Tote Box With Frame (includes TB92035NAT tote & frame)	<b>SXRH3TOTE</b>
HD 6" Hanging Tote Box With Frame (Includes TB92060NAT tote & frame)	<b>SXRH6TOTE</b>
HD 8" Hanging Tote Box With Frame (Includes TB92080NAT tote & frame)	<b>SXRH8TOTE</b>

Shelves

HD Single Wide Poly Shelf	<b>SXRSOHPS</b>
HD Double Wide Poly Shelf	<b>SXRDOHPS</b>
HD Single Wire Shelf	<b>SXRSOHWE</b>
HD Double Wide Wire Shelf	<b>SXRDOHWE</b>
Sgl Wide Vertical Shelf Divider Kit (with (2) divider brackets & (2) vertical dividers)	<b>SXRSH-VSHFDIV</b>
Dbl Wide Vertical Shelf Divider Kit (with (2) divider brackets & (2) vertical dividers)	<b>SXRDH-VSHFDIV</b>
Extra Vertical Shelf Divider	<b>SXRHVDIV-1</b>
Divider Kit (Looped Style) for Single Wide Polymer Inner Panels	<b>SXRSOHDIV</b>
Divider Kit (Looped Style) for Double Wide Polymer Inner Panels	<b>SXRDOHDIV</b>

Tambour Door Mobile Unit Accessory

Description	Cat. No.
Extended Handle (left or right side)	<b>SXREHAN-TMBD</b>



SXRHCATH



SXRH3TOTE



SXRSOHPS

Starsys Carts are built to exact customer specifications, therefore, they are non-cancelable, non-returnable.

## Starsys™ Drawers

Starsys offers two types of drawers to address varying user requirements. Below is a feature comparison to help determine the appropriate drawers system for a desired application.

Feature	Polymer Drawers	Heavy-Duty Drawers
Light to medium weight capacity (25-40 lbs.)	X	
Heavy weight capacity (up to 100 lbs.)		X
Removable tote	X	
Inner panel compatible	X	
Slotted post insert compatible		X
Ball bearing slide		X
Full extension	X	X
Stainless steel interior		X
Polymer interior	X	
Easy to clean	X	
Easily removed/reconfigured	X	
Adjustable dividers	X	X
Lockable	X	X
Optional lock cover	X	
Label kits	X	X
Accommodate hanging files		X



Removable drawer totes allow for exchange or convenient access outside of cart



Heavy-Duty Drawer

## Starsys™ Doors

Starsys offers two types of doors, hinged and tambour. The hinged doors are available in a choice of solid or clear. Each offers unique benefits to address varying user requirements. Below is a feature comparison to help determine the appropriate door selection for a desired application.

Feature	Hinged Solid Door	Hinged Clear Door	Rollup Tambour Door	Benefit
Visual Security	X		X	Puts inventory out of plain site
Hides clutter	X		X	Enhances department aesthetics
Visual inventory		X		Protection is not compromised when looking for supplies
Lockable	X	X	X	Added security
Space saving			X	Does not encroach on work space
Door swing overlaps adjacent storage spaces	X	X		Promotes door closure to protect supplies ( <b>Joint Commission requirement</b> )
90 degree hinge	X	X		Prevents door from overlapping adjacent space
270 degree hinge	X	X		Allows door to swing to side of cabinet or cart
Polymer	X	X	X	Impact and corrosion protection
Left or right hinge	X	X		Provides appropriate swing direction
Center closing	X	X		Allows for double wide storage compartments
Door label holders	X	X		Provides clean replenishable labeling option
Non-locking	X	X		Lower cost alternative



Solid Doors



Clear Doors



Tambour Door

To configure a Starsys unit to your exact specifications, please visit [www.metroconfigurator.com](http://www.metroconfigurator.com)



# STARSYS™



Overhead cabinet shelves are removable, easy-to-clean, and are available in both solid polymer and epoxy-coated, open-wire shelf designs.

Starsys mobile workcenter units can be specified with or without overhead cabinets attached. Available overhead heights include 24", 27", 30", and 36".

Overhead cabinet accessories include light fixture, cassette bins for small item storage and organization, and poly shelf dividers.

Overhead cabinets can be specified with a variety of available doors, clear or solid style, locking or non-locking.

Color-coded drawer pulls are available in an array of choices to fit any system or decor.

Standard countertop choices include laminate, stainless steel, phenolic and solid surface.

Starsys Doors, available in multiple heights, can be specified with or without window, as well as locking and non-locking.

Microban® antimicrobial protection inhibits the growth of stain and odor-causing bacteria on Starsys, keeping the surface areas "cleaner between cleanings."

Additional caster options are available through Starsys configurator.com or by contacting your Metro representative.

Starsys drawer options include choice of polymer drawers or heavy-duty drawers featuring stainless steel drawer interior. Heavy-duty drawers are available in both single- and double-wide modules.

5" (127mm) polyurethane casters with easily accessed toe brake make for easy rolling.



Starsys Mobile WorkCenters are built for change. They allow you to easily adapt to a changing work environment and even inspire change in your work environment.

Total Unit Height: All units with overhead storage have a total height of 82" (2083mm) (with 5" casters). Deduct 2" from unit height when specifying 3" Total-Lock casters or Leveling casters.

Available Widths: Starsys Mobile WorkCenters are available in four widths; single: 24" (610mm), double: 44" (1118mm), triple: 63" (1600mm) & single-kneewell-single: 73" (1854mm).

Working heights with Overheads: 33", 36", 39", 42" (45" height is not available with overhead storage)

Kneewell Options: Starsys Mobile WorkCenters configurations have several kneewell options including a keyboard tray, pencil drawer and support bracket. The triple unit has a right oriented kneewell option with a nominal opening of 42" (1067mm) and the single-kneewell-single configuration has a nominal opening of 30" (762mm).

Working Heights: Available working heights without overhead storage: 33", 36", 39", 42", 45" (with 5" casters). Deduct 2" (51mm) from unit height when specifying 3" Total-Lock casters or Leveling casters.

<p>3" Total-Lock Caster: Utilize 3" total-lock plate casters for limited mobile applications or when additional storage area is required.</p>  <p>B3P-TL</p>	<p>5" Total-Lock, All-Polymer Caster: Recommended for corrosive environments. All-polymer total-lock plate caster is an economical alternative to stainless casters.</p>  <p>B5PC-TL</p>	<p>Stabilizer/Leveling Caster: Recommended for applications where benchtop equipment demands unit stability and/or a level worksurface. Engage caster foot for stability, release for mobility.</p>  <p>B3N-AS</p>
---	---	---

Starsys Carts are built to exact customer specifications, therefore, they are non-cancelable, non-returnable.

Preconfigured Mobile WorkCenters  
Mobile WorkCenters with Laminate Tops



Cat. No. **SXRSENT1**



Cat. No. **SXRDEMT2**



Cat. No. **SXR40MW10**



Cat. No. **SXRT38MW14**

Alternate top materials  
and finishes available.



Cat. No. **SXRK32MW5**



Cat. No. **SXRK32MW6**



Cat. No. **SXRK41MW7**

To configure a Starsys unit to your exact specifications, please visit [www.metroconfigurator.com](http://www.metroconfigurator.com)



# STARSYS™



## Starsys WorkCenters

Starsys WorkCenters are designed to be a fully integrated, fully adaptable, modular system. WorkCenters can be stand alone products or can be configured section within a larger product configuration. WorkCenters combine valuable lower storage areas with finished modular countertops to offer a complete storage and work area solution. Starsys WorkCenters are made up of two key components: base units and countertops. Understanding how these two elements work together is the key to understanding the Starsys WorkCenters line. While sections of Starsys WorkCenters can be configured into many physical combinations, these sections are typically divided into two categories: “straight run” or “corner” configurations.

**Working Heights:** Starsys WorkCenters are available in the following working heights: 30" (762mm), 33" (838mm), 36" (914mm), 39" (990mm) and 42" (1067mm). Within each working height there is up to 2.5" (64mm) of additional height adjustment via the four adjustable leveling feet in each base unit.

## Starsys Base Units

Base units are the products that provide valuable lower storage areas, as well as providing the necessary support for countertops. Base units are the most critical part of a configuration with countertops. Their total combined length and placement will determine the length of the associated countertops in the design. Their placement will determine the placement and size of necessary knee wells and provide support for valuable corner work areas. All Starsys base units are available in light taupe but have the flexibility to be accented with various door & drawer handle colors. Countertop color selection and cove base color selections may be used to accent the base unit color.

**System Widths:** Base Units are available in Single and Double widths.

**System Heights:** Base Units are designed to work with the following nominal countertop heights: 30" (762mm), 33" (838mm), 36" (914mm), 39" (990mm) & 42" (1067mm).

For overhead units and accessories, see pages 163-166.

Microban® antimicrobial protection inhibits the growth of stain and odor-causing bacteria on Starsys, keeping the surface areas “cleaner between cleanings.”

Starsys Carts are built to exact customer specifications, therefore, they are non-cancelable, non-returnable.

### WorkCenter Countertop Colors

- Laminate and solid surface offerings provide a variety of color options that work flawlessly with all body and pull combinations.
- Multiple color options to compliment any decor.
- Special colors and materials are available upon request.

#### Solid Surface Colors

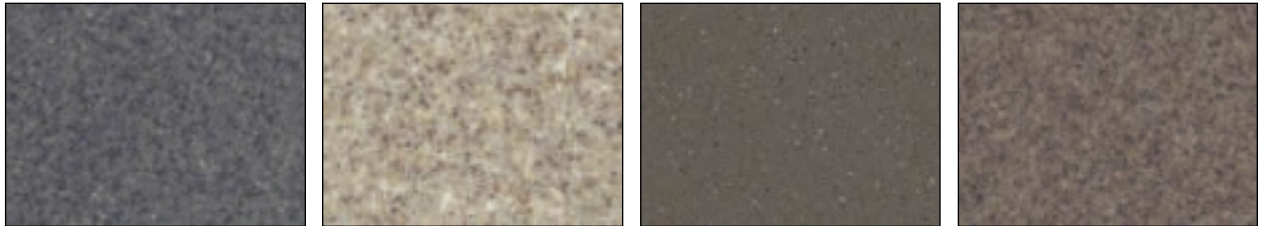

Flint

Matterhorn

Medea

Silt

**Note:** Colors may be discontinued at any time. Please verify with your local representative.

#### Laminate Colors

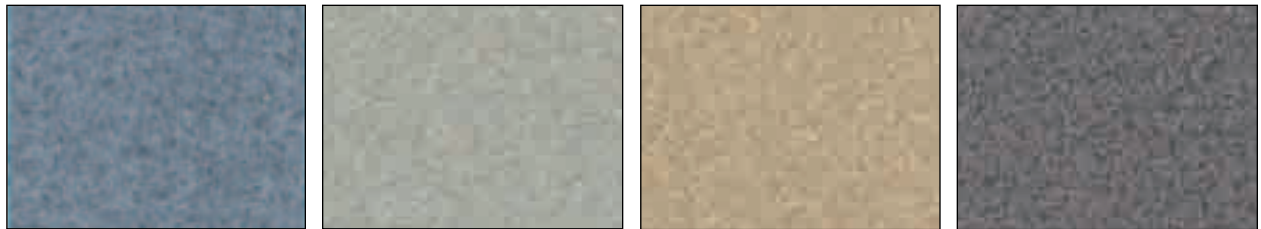

Mystique Marine

Nickel EV

Tungsten EV

Carbon EV

**Note:** Colors may be discontinued at any time. Please verify with your local representative.

### Preconfigured WorkCenters

30"



Cat. No. **SXR30WC1**



Cat. No. **SXR30WC3**



Cat. No. **SXR30WC6**

To configure a Starsys unit to your exact specifications, please visit [www.metroconfigurator.com](http://www.metroconfigurator.com)

Preconfigured WorkCenters

36"



Cat. No. **SXR36WC2**



Cat. No. **SXR36WC5**



Cat. No. **SXR36WC6**



Cat. No. **SXR36WC10**



Cat. No. **SXR36WC11**



Cat. No. **SXR36WC12**



Cat. No. **SXR36WC13**



Cat. No. **SXR36WC15**



Cat. No. **SXR36WC16**

Starsys Carts are built to exact customer specifications, therefore, they are non-cancelable, non-returnable.

Preconfigured WorkCenters

39"



Cat. No. **SXR39WC3**



Cat. No. **SXR39WC10**



Cat. No. **SXR39WC12**



Cat. No. **SXR39WC13**



Cat. No. **SXR39WC14**



Cat. No. **SXR39WC16**

To configure a Starsys unit to your exact specifications, please visit [www.metroconfigurator.com](http://www.metroconfigurator.com)



Back Wall Trim Kit



Corner Filler Kits



30° Kneewell Bracket with Pencil Drawer Option

### Base Unit Trim Kits

Description	Cat. No.
<b>Back Wall Trim Kits — 25" Deep Countertops</b>	
Back Wall Trim Kit x 39 (all heights)	<b>SXR39BKFLR</b>
<b>Back-to-Back Cabinet Trim Kits — 25" Deep Countertops</b>	
Back to Back Filler for 30" H — 25" Countertop	<b>SXR30BBFLR</b>
Back to Back Filler for 33" H — 25" Countertop	<b>SXR33BBFLR</b>
Back to Back Filler for 36" H — 25" Countertop	<b>SXR36BBFLR</b>
Back to Back Filler for 39" H — 25" Countertop	<b>SXR39BBFLR</b>
Back to Back Filler for 42" H — 25" Countertop	<b>SXR42BBFLR</b>
<b>Back Wall Trim Kits — 30" Deep Countertops</b>	
Back Wall Trim for 30" H — 30" Countertop	<b>SXR30BKFLR30</b>
Back Wall Trim for 33" H — 30" Countertop	<b>SXR33BKFLR30</b>
Back Wall Trim for 36" H — 30" Countertop	<b>SXR36BKFLR30</b>
Back Wall Trim for 39" H — 30" Countertop	<b>SXR39BKFLR30</b>
Back Wall Trim for 42" H — 30" Countertop	<b>SXR42BKFLR30</b>
<b>Back-to-Back Cabinet Trim Kits — 30" Deep Countertops</b>	
Back to Back Filler for 30" H — 30" Countertop	<b>SXR30BBFLR30</b>
Back to Back Filler for 33" H — 30" Countertop	<b>SXR33BBFLR30</b>
Back to Back Filler for 36" H — 30" Countertop	<b>SXR36BBFLR30</b>
Back to Back Filler for 39" H — 30" Countertop	<b>SXR39BBFLR30</b>
Back to Back Filler for 42" H — 30" Countertop	<b>SXR42BBFLR30</b>
<b>Unit-to-Unit Filler Kits</b>	
Unit to Unit Filler Strip Kit (10 pieces/kit)	<b>SXR72UUFLR</b>
<b>Corner Filler Kits</b>	
45 Degree Corner Filler Strip Kit x 84	<b>SXR84CR45FLR</b>
90 Degree Corner Filler Strip Kit x 84	<b>SXR84CR90FLR</b>

### WorkCenter Base Unit Accessories

Description	Cat. No.
<b>Kneewell Options and Accessories</b>	
Undercounter Keyboard Tray	<b>SXRKYBDTRY</b>
30 Brkt Assembly Blank	<b>SXR30BRKT</b>
30 Brkt Assembly Keyboard Tray	<b>SXR30BRKTKB</b>
30 Brkt Assembly Pencil Drawer	<b>SXR30BRKTPN</b>
42 Brkt Assembly Blank	<b>SXR42BRKT</b>
42 Brkt Assembly Keyboard Tray	<b>SXR42BRKTKB</b>
42 Brkt Assembly Pencil Drawer	<b>SXR42BRKTPN</b>
<b>Sink Valance</b>	
Sink Valance Kit	<b>SXRSINKVLC</b>
<b>Floor Mounting Kit</b>	
Floor Mounting Kit	<b>SXR-FLR</b>

Starsys Carts are built to exact customer specifications, therefore, they are non-cancelable, non-returnable.



# STARSYS™



**StarSYS Overhead Storage Solutions:** The Starsys line offers two solutions when additional wall storage is required above a WorkCenter or when overhead storage is required above a Mobile WorkCenter.

**StarSYS Tambour Door Units** — are not available in modular sizes, they have a fixed height, width & depth. The door, lock and bottom shelf are always included in the Tambour Door units. Accessories ship separate. Mounting hardware not included.

Height: 30" (762mm)  
 Depth: 14" (356mm)  
 Width: 19.5" (492mm)

Available accessories include: full depth shelves, tilt-bins, shelf bins, under-cabinet shelves, under-cabinet lighting and back filler kits. The necessary wall mount rails/hardware are included with each wall cabinet. (wall anchoring hardware is not supplied by InterMetro).

**StarSYS Half-Depth Overhead Storage Units** — are built on the same widths as Starsys base units utilizing very similar construction, insuring that wall cabinets align with the lower product configuration in your application. Starsys Overhead Cabinets are available as single or double width cabinets in the following interior heights:

24", 27", 30", 33", 36" [610mm, 686mm, 762mm, 838mm, 914mm] (add 2.5" [64mm] for overall exterior height).

All Starsys overhead cabinets include corrugated polymer inner panels in their assembly as well as a clean-design back panel, molded with the cosmetic side facing the inside of cabinet, creating a much cleaner appearance — especially when used without doors or in conjunction with a clear door. The necessary wall mount rails/hardware are included with each wall cabinet. (wall anchoring hardware is not supplied by InterMetro).

Microban® antimicrobial protection inhibits the growth of stain and odor-causing bacteria on Starsys, keeping the surface areas "cleaner between cleanings."

To configure a Starsys unit to your exact specifications, please visit [www.metroconfigurator.com](http://www.metroconfigurator.com)

### Overhead Wall Cabinet Shells

Solid and clear, Locking or non-locking Doors available for all wall cabinet sizes.



Single-wide shell



Double-wide shell



4 Level Cassette

Description	Dimensions Depth/Width/Height (in.)	Cat. No.
<b>Single-Wide Shells</b>		
24" Single Overhead Shell	14x21.5x27.5	SXRSOH24P
27" Single Overhead Shell	14x21.5x29.5	SXRSOH27P
30" Single Overhead Shell	14x21.5x32.5	SXRSOH30P
33" Single Overhead Shell	14x21.5x35.5	SXRSOH33P
36" Single Overhead Shell	14x21.5x38.5	SXRSOH36P
<b>Double-Wide Shells</b>		
24" Double Overhead Shell	14x41.3x27.5	SXRDOH24P
27" Double Overhead Shell	14x41.3x29.5	SXRDOH27P
30" Double Overhead Shell	14x41.3x32.5	SXRDOH30P
33" Double Overhead Shell	14x41.3x35.5	SXRDOH33P
36" Double Overhead Shell	14x41.3x38.5	SXRDOH36P
<b>Triple-Wide Shells*</b>		
24" Triple Overhead Shell	14x61.2x27.5	SXRTOH24P
27" Triple Overhead Shell	14x61.2x29.5	SXRTOH27P
30" Triple Overhead Shell	14x61.2x32.5	SXRTOH30P
33" Triple Overhead Shell	14x61.2x35.5	SXRTOH33P
36" Triple Overhead Shell	14x61.2x38.5	SXRTOH36P

\*Triple-Wide Shells are for use with Mobile WorkCenters only.

### Starsys Wall Cabinet Accessories

Description	Cat. No.
<b>Wall Cabinet Shelving</b>	
Single-wide Overhead Polymer Shelf	SXRSOHPS
Single-wide Overhead Wire Shelf	SXRSOHWE
Double-wide Overhead Polymer Shelf	SXRDOHPS
Double-wide Overhead Wire Shelf	SXRDOHWE
<b>Wall Cabinet Shelf Divider Kits</b>	
Single-wide Overhead Shelf Divider Kit (Looped Style)	SXRSOHDIV
Double-wide Overhead Shelf Divider Kit (Looped Style)	SXRDOHDIV
Single-wide Vertical Shelf Divider Kit (with (2) divider brackets & (2) vertical dividers)	SXRSH-VSHFDIV
Double-wide Vertical Shelf Divider Kit (with (2) divider brackets & (2) vertical dividers)	SXRDH-VSHFDIV
Extra Vertical Shelf Divider	SXRHVDIV-1
<b>Under Cabinet Lighting</b>	
Single-wide Overhead Light (Valance and 1 Light)	SXRSOHL
Double-wide Overhead Light (Valance and 1 Light)	SXRDOHL
Triple-wide Overhead Light (Valance and 2 Lights)	SXRTOHL
Additional Overhead Light	SXROHLT
<b>Sloped Tops — Wall Cabinets</b>	
Single-wide Overhead Sloped Top	SXRSOHSLTOP
Double-wide Overhead Sloped Top	SXRDOHSLTOP
<b>Filler Kits — Additional Wall Mount Rails and Covers</b>	
49" (1245mm) Overhead Back Filler Kit	SXROHFLR-49
63" (1600mm) Mounting Rail Cover Kit	SXROHFLR-63
Additional Single-wide Wall Mount Bracket Kit (1 Pair)	SXROHWB-22
Additional Double-wide Wall Mount Bracket Kit (1 Pair)	SXROHWB-42

Starsys Carts are built to exact customer specifications, therefore, they are non-cancelable, non-returnable.

27"



Cat. No. **SXRSOH27P2C**



Cat. No. **SXR5OH27P2N**



Cat. No. **SXRSOH27P2S**



Cat. No. **SXRDOH27P2C**



Cat. No. **SXRDOH27P2N**



Cat. No. **SXRDOH27P2S**



Cat. No. **SXRDOH27W2C**

Starsys Tambour Door Overhead Cabinet and Accessories

Description	Cat. No.
Overhead Cabinet	<b>SXROH</b>
Overhead Light	<b>SXROHLIGHT</b>
Overhead Shelf Assembly	<b>SXROHSHF</b>
Overhead Full Width Shelf	<b>SXRFULSHLF</b>
Starsys Tilt-out Bin	<b>SXRTLBIN</b>
Overhead Filler Kit	<b>SXROHFLR</b>
Shelf Supply Bin — Order in Multiples of 12	<b>MB30230B</b>
Shelf Supply Bin — Order in Multiples of 6	<b>MB30235B</b>
3" (76mm) wide Cassette Bin	<b>SXRBINSB3</b>
4 1/2" (114mm) wide Cassette Bin	<b>SXRBINSB4</b>
6" (152mm) wide Cassette Bin	<b>SXRBINSB6</b>
8" (203mm) wide Cassette Bin	<b>SXRBINSB8</b>



To configure a Starsys unit to your exact specifications, please visit [www.metroconfigurator.com](http://www.metroconfigurator.com)

### Starsys™ Secure I.V. Cart

The Starsys Secure I.V. Cart is a system of polymer components that offers security in a flexible storage/transport solution.

- Easily Accessible: Full extension shelves allow for I.V. solution bags to be stored standing upright or lying down while providing complete access to the entire product.
- Joint Commission Compliant: The locking feature is in compliance with the Joint Commission’s medication storage standards.
- Corrosion Resistant: Corrosion-proof polymer components ensure a contamination-free environment.
- Durable: Easy to clean polymer enclosures won’t chip, rust, or dent.
- Easily Maneuverable: The lighter polymer design and 5" (127mm) casters, two with brakes, allow for easier movement and transfer of product.
- Microban® Antimicrobial product protection inhibits the growth of stain and odor-causing bacteria on Starsys, keeping the surface areas “cleaner between cleanings”.



SXRSIVSTOR

Description	Height/Width/Length (in.)	(mm)	Total Totes per Cart	Cat. No.
Single-Wide	59 <sup>3</sup> / <sub>4</sub> x27 <sup>7</sup> / <sub>8</sub> x22 <sup>11</sup> / <sub>16</sub>	1518x708x576	3	SXRSIVSTOR
Double-Wide	59 <sup>3</sup> / <sub>4</sub> x27 <sup>7</sup> / <sub>8</sub> x42 <sup>1</sup> / <sub>2</sub>	1518x708x1080	6	SXRDIVSTOR

Units feature four 5" (127mm) casters — the front two casters have color-matched toe-brakes. The dimensions of the tote boxes (MTB93080W) that are included are 8x17<sup>1</sup>/<sub>2</sub>x22<sup>1</sup>/<sub>2</sub> (203x445x572mm).



Suture Storage



Stent and Graft

### Suture Storage

Description	Cat. No.
Suture Storage Module	SXRSUTURE

**Note:** This accessory requires a polymer interior. The SXRSUTURE requires 30" (762mm) of vertical space and is available in single width only.

### Stent and Graft

Description	Cat. No.
Stent and Graft Module	SXRSGM

**Note:** This accessory requires a qwikSLOT interior. The SXRSGM requires 30" (762mm) of vertical space and is available in single width only.



Starsys utilizing bins for sterile instrument storage



To configure a Starsys unit to your exact specifications, please visit [www.metroconfigurator.com](http://www.metroconfigurator.com)

### Catheter Storage

Dimensions Width/Length (in.) (mm)		Height (in.) (mm)		Catheter Cap.	Style	Cat. No.*
<b>Mobile Units</b>						
25x23	635x584	76	1930	180	Single-Wide	<b>SXRS76MCATH1</b>
25x43	635x1092	76	1930	360	Double-Wide	<b>SXRD76MCATH1</b>
25x43	635x1092	76	1930	180	Double-Wide	<b>SXRD76MCATH2</b>
<b>Stationary Units</b>						
25x21	635x533	72	1829	180	Single-Wide	<b>SXRS72SCATH1</b>
25x41	635x1041	72	1829	360	Double-Wide	<b>SXRD72SCATH1</b>
25x41	635x1041	72	1829	180	Double-Wide	<b>SXRD72SCATH2</b>

\*Configurations:  
 Single Wide 1 = 1 - 270° locking door; 1 Catheter Module with 3 slides, 30 labels and 15 hooks.  
 Double Wide 1 = 2 - 270° locking doors; 2 Catheter Modules each with 3 slides, 30 labels and 15 hooks.  
 Double Wide 2 = 1 - 270° locking door; 1 Catheter Module with 3 slides, 30 labels and 15 hooks plus  
 1 - 3" (76mm) drawer, 2 - 6" (150mm) drawers and 2 - 9" (230mm) drawers, 3 shelves, a 270° non-locking  
 door and a push handle.

### Accessories

Description	Overall Dimensions (in.) (mm)		Cat. No.
Catheter Storage Module (Consists of 1 shelf, 3 slides, 30 labels, 15 hooks)			<b>SXRCATH</b>
5 pack Catheter Hooks (Holds up to 12 catheters)			<b>SXRCATHHK</b>
Catheter Shelf			<b>SXRCATH-SHF</b>
1 Slide, 10 Labels, 5 Hooks			<b>SXRCATHSLD</b>
*Extended Handle Assembly	4x21½x4½	102x546x114	<b>SXREHAN</b>

\*Field retrofittable. Order as SXREHAN-KD.



SXRS72SCATH1

SXRS76MCATH1



SXRD76MCATH1

SXRD76MCATH2

SXRD72SCATH1

SXRD72SCATH2

#### Catheter Shelf (SXRCATH-SHF)

- Shelf locks into place so it does not pull out as slide is extended.
- Removable without tools.
- Adjustable on 1½" (38mm) increments.
- Dual role:
  - Stores hanging catheters below
  - Also serves as a shelf for supplies
- Shelf is epoxy-coated steel
- Weight capacity: 75 lbs. (34kg) (includes weight of slides, catheters and supplies)
- Dimensions: 6¾"Hx17⅛"Wx21"D (162x454x533mm)

#### Catheter Slide (SXRCATH-SLD)

- Built-in stop keeps slide from extending when closed.
- Can hold up to total of 10 hooks.
- Hooks can be oriented in one of three ways: Left, right or straight forward.
- Pull handle also serves as label holder.
- Label size: 2½"Wx3⅞"H (64x98mm)
- Weight capacity (per slide): 25 lbs. (11.3kg)
- Slide Extension: 20" (508mm)
- Accommodates maximum length of 60½" (1527mm).

#### Catheter Hook (SXRCATHHK)

- The catheter hook can be installed on the slide without tools. The hook can be rotated on 90 degree intervals so the catheters can hang off to the left of the slide, to right of the slide or directly below the slide. Maximum storage capacity can be attained with three slides (10 hooks per slide) when the hooks alternate left to right from slot to slot.
- Consists of 1 bag of 5 hooks
  - Capacity: Up to 12 catheters
  - Maximum Weight Capacity (per hook): 5 lbs. (2kg)



Starsys Carts are built to exact customer specifications, therefore, they are non-cancelable, non-returnable.

**Starsys Scope Cabinet — 45.60**

The Starsys scope cabinet is a high-density storage solution, which provides quick access and retrieval, visual inventory and easy identification.

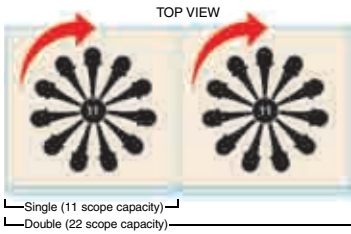

Scope brackets, cord managers, and bottom hoop are all adjustable in 1" (25mm) increments. This allows you to raise or lower them (without tools) to accommodate the scope length you are storing.



The mid-level cord manager is used for all types of scopes, and is also orange coated. It keeps cords from tangling and provides strain relief for light boxes or connectors.



Two-piece plastic drip pan contains remaining fluids and is easily removed for cleaning and drying.

The Metro® Carousel™ rack rotates, giving you easy access to any scope.

**Scope Cabinets**



SXRS88WSC1LS

SXRS88WSC1LC

(in.)	Height/Depth/Width (mm)	Description	Cat. No.
89x24 1/2 x 21 5/8	2261x622x549	Single-wide scope cabinet with Carousel Assembly (No scope brackets or door)	<b>SXRS88WSC</b>
89x24 1/2 x 21 5/8	2261x622x549	Single-wide scope cabinet/left-hinged SOLID locking door/11 GI Scope Brackets	<b>SXRS88WSC1LS</b>
89x24 1/2 x 21 5/8	2261x622x549	Single-wide scope cabinet/right-hinged SOLID locking door/11 GI Scope Brackets	<b>SXRS88WSC1RS</b>
89x24 1/2 x 21 5/8	2261x622x549	Single-wide scope cabinet/left-hinged CLEAR locking door/11 GI Scope Brackets	<b>SXRS88WSC1LC</b>
89x24 1/2 x 21 5/8	2261x622x549	Single-wide scope cabinet/right-hinged CLEAR locking door/11 GI Scope Brackets	<b>SXRS88WSC1RC</b>
89x24 1/2 x 43 1/4	2261x622x1098	Double-wide scope cabinet with Carousel Assembly (No scope brackets or door)	<b>SXRD88WSC</b>
89x24 1/2 x 43 1/4	2261x622x1098	Double-wide scope cabinet/left & right-hinged SOLID locking door/22 GI Scope Brackets	<b>SXRD88WSC1</b>

**Note:** All doors have a 225° swing and taupe pulls.

**Doors**

Description	Cat. No.
83" H. (2108mm), Left-hinged, 225° Locking, Solid, Vented	<b>SXRDRB83L1BSV</b>
83" H. (2108mm), Left-hinged, 270° Locking, Solid, Vented	<b>SXRDRB83L2BSV</b>
83" H. (2108mm), Right-hinged, 225° Locking, Solid, Vented	<b>SXRDRB83R1BSV</b>
83" H. (2108mm), Right-hinged, 270° Locking, Solid, Vented	<b>SXRDRB83R2BSV</b>
83" H. (2108mm), Left-hinged, 225° Locking, Clear, Vented	<b>SXRDRB83L1BCV</b>
83" H. (2108mm), Left-hinged, 270° Locking, Clear, Vented	<b>SXRDRB83L2BCV</b>
83" H. (2108mm), Right-hinged, 225° Locking, Clear, Vented	<b>SXRDRB83R1BCV</b>
83" H. (2108mm), Right-hinged, 270° Locking, Clear, Vented	<b>SXRDRB83R2BCV</b>

**Scope Brackets**



Scope Brackets with Label Holder

Description	Cat. No.
GI (large) Scope Bracket — Orange (maximum weight load 5 lbs. [2.7kg])	<b>SXRSCP1</b>
Pulmonary (small) Scope Bracket — Blue (maximum weight load 5 lbs. [2.7kg])	<b>SXRSCP2</b>

**Label Holders**

Height/Width (in.)	Width (mm)	Description	Cat. No.
1 1/4 x 3	31x76	12 pk. Label Holder for Scope Bracket	<b>SXRSCPLBL</b>
1x16	25x406	10 pk. Label Holder for Door, Holds Paper Labels (not included)	<b>SXRLABKIT</b>

**Filler Kits**

Description	Cat. No.
Pair of 88" H. (2235mm) Back of Cabinet to Wall Filler Kit	<b>SXR88BKFLR*</b>
One 83" H. (2108mm) Unit to Unit Filler Kit for 88" (2235mm) Units	<b>SXR88UJFLR**</b>

\*Back filler kit is used when cabinet is adjacent to a run of WorkCenters. It fills the gap behind the unit when the unit is pulled away from the wall to be flush with front of countertop.

\*\*Unit to unit filler kit is used to hide the seam between two adjacent units.

To configure a Starsys unit to your exact specifications, please visit [www.metroconfigurator.com](http://www.metroconfigurator.com)



# STARSYS™ Ultimate modularity. Unlimited choices.

When you think about space, you may think about efficiency.  
Or better organization. Maybe the freedom to be flexible.

**Complete Storage System** — Addresses applications facility-wide.

**Interchangeable Components** — Provides flexibility to address changing needs.

**Modular Design** — Provides flexibility to change layout and/ or location.

**Highly Configurable** — Design on wheels, with countertops, even on the walls.

**Polymer Construction** — Maintains function and aesthetic over time.



Starsys. It's a concept worth thinking about.



Metro incorporates several elements in its product design to support a facility's cleaning protocols:

- Microban® antimicrobial protection helps prevent the growth of stain and odor causing bacteria on the product.
- Advanced polymer and other proprietary finishes provide corrosion resistance
- Smooth rounded corners to allow for easier cleaning

Look for the "red check" symbol for this added protection.



# CARTS

Emergency Carts .....	176-181
Procedure Carts — Polymer .....	182-193
Procedure Carts — Metal .....	194-211
Case Carts .....	212-213
Procedural Support .....	214
Specialty Carts & Storage .....	215-218
Storage & Transport/Exchange Carts .....	219-225
Totes, Slides & Accessories.....	226-227
Linen Carts and Trucks.....	228-229



# Lifeline™

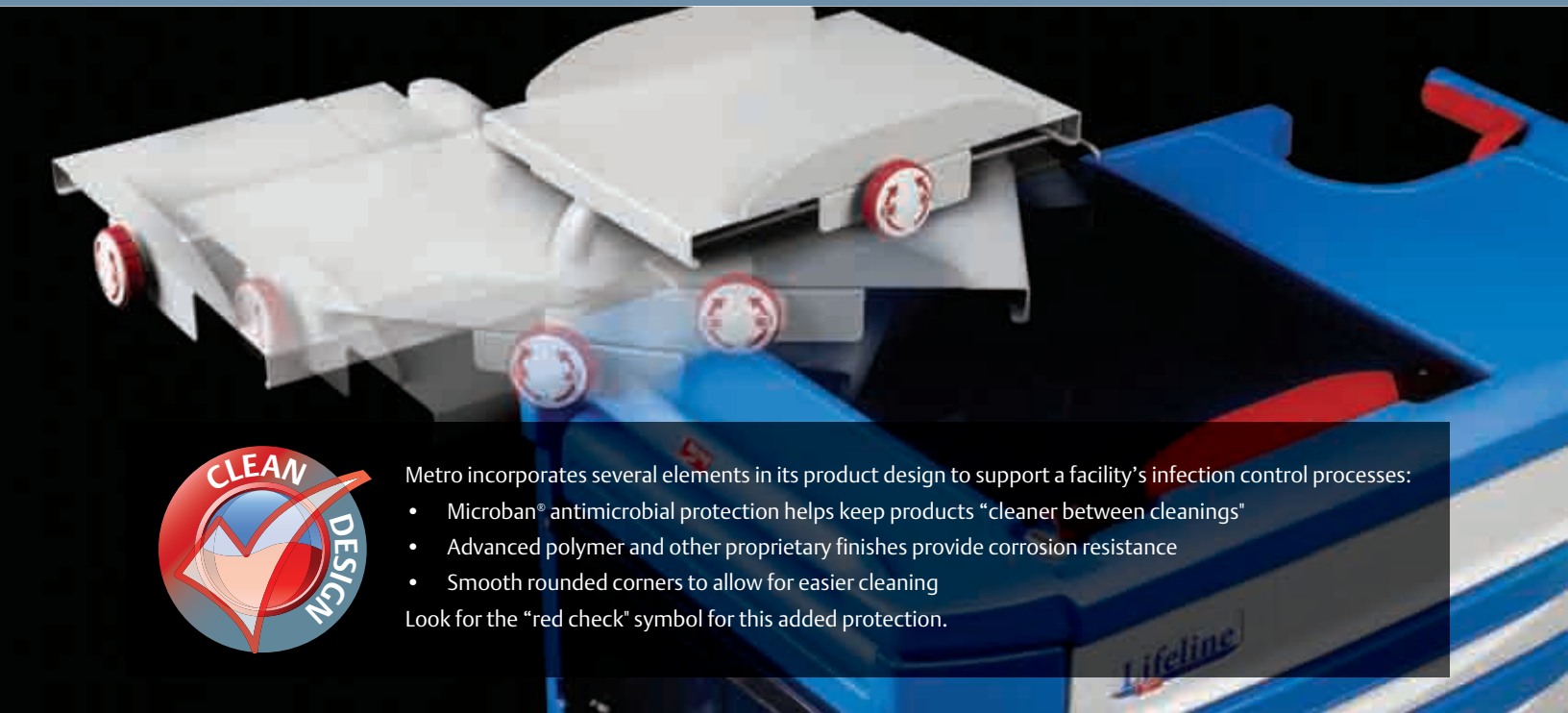

Metro incorporates several elements in its product design to support a facility's infection control processes:

- Microban® antimicrobial protection helps keep products "cleaner between cleanings"
- Advanced polymer and other proprietary finishes provide corrosion resistance
- Smooth rounded corners to allow for easier cleaning

Look for the "red check" symbol for this added protection.

## Lifeline. Save lives together!

**FIND IT FAST.**  
Get organized with Lifeline. Drawer dividers and trays make finding critical medications and supplies easy.



**BE EFFICIENT.**  
Have simultaneous access to medications and supplies by multiple code team members.

**TAKE CONTROL.**  
5th wheel steering Assist assures maximum control in transit and maneuverability during a code.

# Designed for a code. Not adapted for one.



## STANDARD DRAWER PULL COLOR



## PEDIATRIC COLOR KIT



- > Advanced polymer construction, rounded corners and Microban antimicrobial product protection help maintain a cleaner cart to improve infection control.
- A. Lightweight polymer construction, ergonomic handle and proprietary 5th-wheel steering system assures maximum control in transit and maneuverability during a code.
- B. Tilt out side bins, top storage compartment and drawers provide simultaneous access to multiple stored products.
- C. Cord management and restraint system keeps cords neatly organized and protects equipment from accidental damage.
- D. Strapless defibrillator platform adjusts to accommodate various defibrillators.
- E. Swingarm positions defibrillator closer to the patient; clears top work area.
- F. Recessed top storage with a clear removable cover provides instant access to first line meds or airway equipment without impeding access to drawers.
- G. Convenience features include an extendable I.V. Pole, O<sub>2</sub> Tank Storage, Suction Pump Shelf, Glove Box Holder, Lockable Sharps Container, Hospital Grade Outlet Strip, Cord Management, Trays & Dividers.
- H. Full extension drawers have self-closing ball bearing slides to provide easy access to medications and supplies. (Drawer depths: 3", 6", 9", 12")
- I. Lock mechanism secures top compartment, drawers and side bins and can be sealed in segments or one seal secures all.
- J. Backboard can be mounted to the front or back of the cart.
- K. Two brake casters positioned in the front of the cart to provide stability.

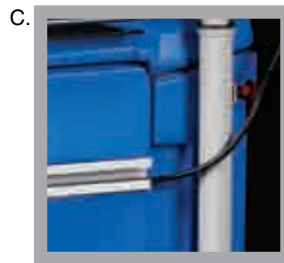
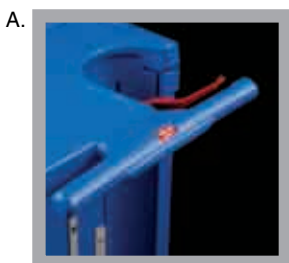

Packages include cart and accessories.



Cat. No. **LECCRP2**  
Code Response Cart



Cat. No. **LECCRP3**  
Code Response Cart



Cat. No. **LECCRP4**  
Code Response Cart



Cat. No. **LECCRP5**  
Code Response Cart



Cat. No. **LECCRP7**  
Code Response Cart



Cat. No. **LECPEDS2**  
Code Response Cart

## Upgradeability.



Basic Cart with side bins and tank holder



Upgrade with defibrillator arm, storage bin and suction shelf



Upgrade again with drawers, trays & dividers

One of the best features about Lifeline is its upgradeability. Start with a basic model based on budget or current requirements and buy the confidence that it can change as your needs change.

Note: Model Numbers shown for carts with open storage below drawers do not include security mechanism for open space. Contact your Metro Representative for a quotation with secure storage space.

### Code Response Preconfigured Carts

Carts shown on the previous pages are configured with the components and accessories listed here.

#### Accessories

Cat. No.	Description	LECCRP2	LECCRP3	LECCRP4	LECCRP5	LECCRP6	LECCRP7	LECCRP8	LECPEDS1	LECPEDS2
FL120	Solid Bottom Shelf				1	1		X		
LEC143	Top Cavity Tray		1		1	1		1		
FL151	3" (76mm) Drawer Divider Tray with Dividers				1	2				7
FL159	6" (152mm) Drawer Divider Tray with Dividers				1	1				1
FL190	Label Holder Set of 10						X			
FL211	Side Bin (1) — Locking		3	3	3		4	3	2	4
FL221	Waste Basket 28 Quart & Holder	X				X			X	
LEC236	Glove Box Holder — Single (Mounts to Handle Side)				X				X	
LEC251	Lockable Sharps Container (Mounts to Handle S ide)	X				X				X
FL302	Cord Manager				X		X			X
LEC304	Adjustable Defibrillator Tray	X	X	X	X	X	X	X	X	X
FL305-4US	Hospital Grade 6-Outlet Strip and Holder (120V)						X			X
LEC306	Suction Pump Shelf		X		X		X	X		X
LEC308	Backboard with Front Assembly Kit		X	X	X	X		X	X	
LEC309	Backboard with Back Assembly Kit	X					X			X
Included	Oxygen Tank Holder	X	X	X	X	X	X	X	X	X
FL315	I.V. Pole with Cart Mount	X	X	X	X	X	X	X	X	X
LEC319	Storage/Gel Bin		X				X	X		
LEC320	Plastic Security Seals 100 Pack	X	X	X	X	X	X	X	X	X
FL403	Individual Drawer Seal Lock Bar									X
LEC-PED8	Pediatric Code Response Drawer Kit								X	X

#### Carts

Cat. No.	Description	LECCRP2	LECCRP3	LECCRP4	LECCRP5	LECCRP6	LECCRP7	LECCRP8	LECPEDS1	LECPEDS2
LEC24P	39" (991mm) Cart	X	X					X		
LEC27P	42" (1067mm) Cart			X	X					
LEC30P	45" (1143mm) Cart					X	X		X	X

#### Drawers, with Cobalt\* Drawer Pull

Cat. No.	Description	LECCRP2	LECCRP3	LECCRP4	LECCRP5	LECCRP6	LECCRP7	LECCRP8	LECPEDS1	LECPEDS2
LEC103	3" (76mm) Drawer	1	2	2	3	4	2	2	7	7
LEC106	6" (152mm) Drawer	3	1	1	1	1	2	1	1	1
LEC109	9" (229mm) Drawer		1		1	1	1			
LEC112	12" (305mm) Drawer			1						

\*Multicolor Drawer Pulls are provided on Pediatric Carts



## 5th wheel maneuverability.

Lightweight polymer construction, ergonomic handle and proprietary 5th-wheel steering system assures maximum control in transit and maneuverability during a code.

To configure a Lifeline cart to your exact specifications, please visit [www.metroconfigurator.com](http://www.metroconfigurator.com)

## Build-a-Cart

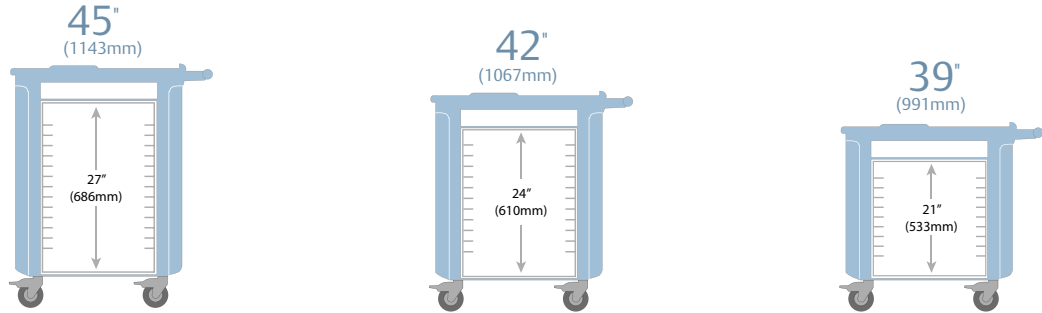

Cart Bodies without Drawers

Width/Length/Height (in.)	Width/Length/Height (mm)	Storage Space (in.) (mm)	Drawer Space (in.) (mm)	Steering Assist	Tank Holder	Cat. No.
22 <sup>5</sup> / <sub>8</sub> x 38 x 38 <sup>3</sup> / <sub>4</sub>	575 x 965 x 984	24 610	21 533	X	X	<b>LEC24P</b>
22 <sup>5</sup> / <sub>8</sub> x 38 x 42 <sup>1</sup> / <sub>8</sub>	575 x 965 x 1070	27 686	24 610	X	X	<b>LEC27P</b>
22 <sup>5</sup> / <sub>8</sub> x 38 x 45 <sup>1</sup> / <sub>2</sub>	575 x 965 x 1156	30 762	27 686	X	X	<b>LEC30P</b>

Note: Width includes optional backboard holders.



STANDARD  
DRAWER PULL  
COLOR  
COBALT



PEDIATRIC  
DRAWER AND  
COLOR KIT  
(Includes drawers,  
colored pulls and  
labels only)

## Additional Security

Description	Cat. No.
Individual Drawer Seal Lock Bar for LEC24P	<b>FL401<sup>F</sup></b>
Individual Drawer Seal Lock Bar for LEC27P	<b>FL402<sup>F</sup></b>
Individual Drawer Seal Lock Bar for LEC30P	<b>FL403<sup>F</sup></b>

<sup>F</sup>Must be factory installed prior to shipment.

## Drawer and Shelf

Description	Cat. No.
3" (76mm) Pull Out Shelf	<b>FL101</b>
3" (76mm) Drawer with Cobalt Pull	<b>LEC103</b>
6" (152mm) Drawer with Cobalt Pull	<b>LEC106</b>
9" (229mm) Drawer with Cobalt Pull	<b>LEC109</b>
12" (305mm) Drawer with Cobalt Pull	<b>LEC112</b>
Solid Bottom Shelf	<b>FL120</b>
Drawer Kit, Pediatric (7-3" Drawers and 1-6" Drawer) <sup>†</sup>	<b>LEC-PED8<sup>**</sup></b>

<sup>†</sup>Inside Drawer Dimensions — 20<sup>1</sup>/<sub>4</sub>" (514mm) wide x 17" (432mm) deep; Heights: 2<sup>3</sup>/<sub>4</sub>" (70mm), 5<sup>1</sup>/<sub>4</sub>" (146mm), 8<sup>3</sup>/<sub>4</sub>" (222mm) 11<sup>3</sup>/<sub>4</sub>" (298mm).

<sup>\*\*</sup>Can only be ordered with a 45" cart.



LEC251

## Right (Handle) Side Accessories

Description	Cat. No.
Glove Box Holder — Single 4" x 10 <sup>1</sup> / <sub>8</sub> " x 6 <sup>3</sup> / <sub>8</sub> " (101 x 258 x 162mm)	<b>LEC236</b>
Lockable Sharps Container 4 <sup>3</sup> / <sub>4</sub> " x 13" x 19 <sup>7</sup> / <sub>8</sub> " (with Glove Box) x 11 <sup>3</sup> / <sub>8</sub> " H (without Glove Box) (121 x 330 x 505 or 302mm)	<b>LEC251</b>
Replacement Containers for LEC251 — 20 5 Quart Containers	<b>FL252</b>
Suction Pump Shelf 12 <sup>1</sup> / <sub>2</sub> " x 15 <sup>1</sup> / <sub>4</sub> " x 4 <sup>1</sup> / <sub>4</sub> " (320x384x108mm)	<b>LEC306</b>
Oxygen Tank Holder*	—

\*Included on all carts



LEC306

Left Side Accessories

Description	Cat. No.
Side Bin (1) — Locking 4 1/2" x 16 3/4" x 8 1/2" (117 x 426 x 216mm)	FL211 <sup>F</sup>
Side Bin (1) — Non-Locking 4 1/2" x 16 3/4" x 8 1/2" (117 x 426 x 216mm)	FL212
Waste Basket 28 Quart & Holder 14 1/2" x 10 7/8" x 15 3/8" (370 x 275 x 390mm)	FL221
Waste Basket 28 Quart	FL222
Bracket for Large Sharps or FL222	FL223
Glove Box Holder — Single 4" x 10 1/8" x 6 3/8" (101 x 258 x 162mm)	FL236
Glove Box Holder — Triple 4" x 10 1/8" x 18 3/8" (101 x 258 x 466mm)	FL237
Sharps Container Bracket — Non-Locking 9 1/2" x 3 1/4" x 9 5/16" (241 x 83 x 237mm)	FL250
Lockable Sharps Container 4 3/4" x 13" x 19 7/8" (with glove box) x 11 3/8" (without Glove Box) (121 x 330 x 505 or 302mm)	FL251
Replacement Containers for FL251 — 20 5 Quart Containers	FL252

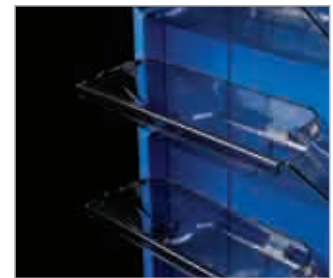

FL211



FL302



FL305



LEC304



LEC309



LEC320 (Designed to work with Metro's Passive Lock System)

Drawer Accessories

Description	Cat. No.
Divider Clip to Attach Loose Short Divider-end to Long Divider, 1 per Short Divider (Qty. 2)	T-CLIP
3" (76mm) Drawer Divider Kit (3 Long, 5 Short, 6 T-Clips)	FL113
Short Divider for LEC103 or FL103 5 Pack 6 7/8" L (175mm)	FL114
Long Divider for LEC103 or FL103 2 Pack 17 1/4" L (437mm)	FL115
6" (152mm) Drawer Divider Kit (2 Long, 5 Short)	FL116
Short Divider for LEC106 or FL106 5 Pack 8" L (205mm)	FL117
Long Divider for LEC106 or FL106 2 Pack 17 1/4" L (437mm)	FL118
Ampule Insert & 12 Divider for Top Cavity or 3" (76mm) Drawer Tray 15 3/4" x 4 7/8" (400 x 124mm)	FL131
Divider for FL131, 12 Pack 5" L (125mm)	FL132
3" (76mm) Egg Crate-Style Drawer Divider Kit — 10 Vertical, 5 Horizontal	FL141
6" (152mm) Egg Crate-Style Drawer Divider Kit — 10 Vertical, 5 Horizontal	FL142
Short Divider for FL141 — Qty. 5 each 10" L (256mm)	FL143
Long Divider for FL141 — Qty. 5 each 17 1/8" L (436mm)	FL144
Short Divider for FL142 — Qty. 5 each 10" L (256mm)	FL145
Long Divider for FL142 — Qty. 5 each 17 1/8" L (436mm)	FL146
Top Cavity Tray — 15" x 15" (381 x 381mm) with 6 Dividers, 4 Short, 2 Long,	LEC143
Sheet of Blank Labels, 5 Security Bags	
Hard Lid for LEC143	LEC144
3" (76mm) Drawer Tray Approx. 20" x 15" (508 x 381mm) with 6 Dividers,	FL151
4 Short, 2 Long, Sheet of Blank Labels, 5 Security Bags	
Lid for 6" (152mm) Drawer Tray	FL158
6" (152mm) Drawer Tray Approx. 19"x15" (483x381mm) with 6 Dividers, 6 Short, 2 Long, 5 Security Bags	FL159
Long Divider Rails for LEC143 or FL151 2 Pack 15 1/2" L (394mm)	FL163
Short Divider for LEC143 or FL151 10 Pack 6 7/8" L (175mm)	FL164
Long Divider for FL159 (2 Pack) 14 3/4" L (375mm)	FL166
Short Divider for FL159 (3 Pack) 8" L (205mm)	FL167
Security Bags for 3" (76mm) & 6" (152mm) Trays	FL183
Security Bags for Top Cavity Tray	LEC185
Label Holder Set of 10 13 3/8" L (346mm)	FL190

Cart Accessories

Description	Cat. No.
Rear Accessory Mount Brackets for I.V. Pole or Defibrillator — 1 Pair	FL301*
Cord Manager 1/2" x 21 3/4" x 1 1/4" (13 x 554 x 31mm)	FL302
Adjustable Defibrillator Tray 8 1/8"-14 1/4" x 14 1/2" (206-362 x 368mm)	LEC304
Hospital Grade 4-Outlet Strip, 120V 15A, UL60601-01, 10' Cord, Cord Wrap	FL305-4US
Universal 6 Outlet Power Strip, 250V 13A, CE, ROHS, 6' (183cm) Cord, Cord Wrap	See Below



FL305-EU UNIVERSAL



FL305-AUS UNIVERSAL



FL305-UK UNIVERSAL



FL305-IT UNIVERSAL



FL305-4-US HOSPITAL GRADE

Backboard with Front and Rear Assembly Kit	LEC307 <sup>F</sup>
Backboard with Front Assembly Kit	LEC308 <sup>F</sup>
Backboard with Back Assembly Kit	LEC309 <sup>F</sup>
I.V. Pole with Cart Mount 1 1/2" x 9 1/8" x 43" (max)-25 1/4" (min) (38 x 232 x 1103-640mm)	FL315
I.V. Pole-Mounted Sharp Brackets	LEC9800
Storage/Gel Bin 7 1/2" x 4 3/8" x 4 1/4" (194 x 111 x 107mm)	LEC319
Plastic Security Seals 100 Pack	LEC320
Backboard 24" x 24" (610 x 610mm)	LEC323

<sup>F</sup>Must be factory installed prior to shipment

\*FL301 brackets are included with accessories noted. FL301 should be ordered factory mounted to carts that anticipate accessories on a later order.

To configure a Lifeline cart to your exact specifications, please visit [www.metroconfigurator.com](http://www.metroconfigurator.com)



# Flexline™



Flexline is constructed of advanced polymers, designed with rounded corners and infused with Microban antimicrobial product protection for a clean, durable solution that withstands the rigors of a healthcare environment.

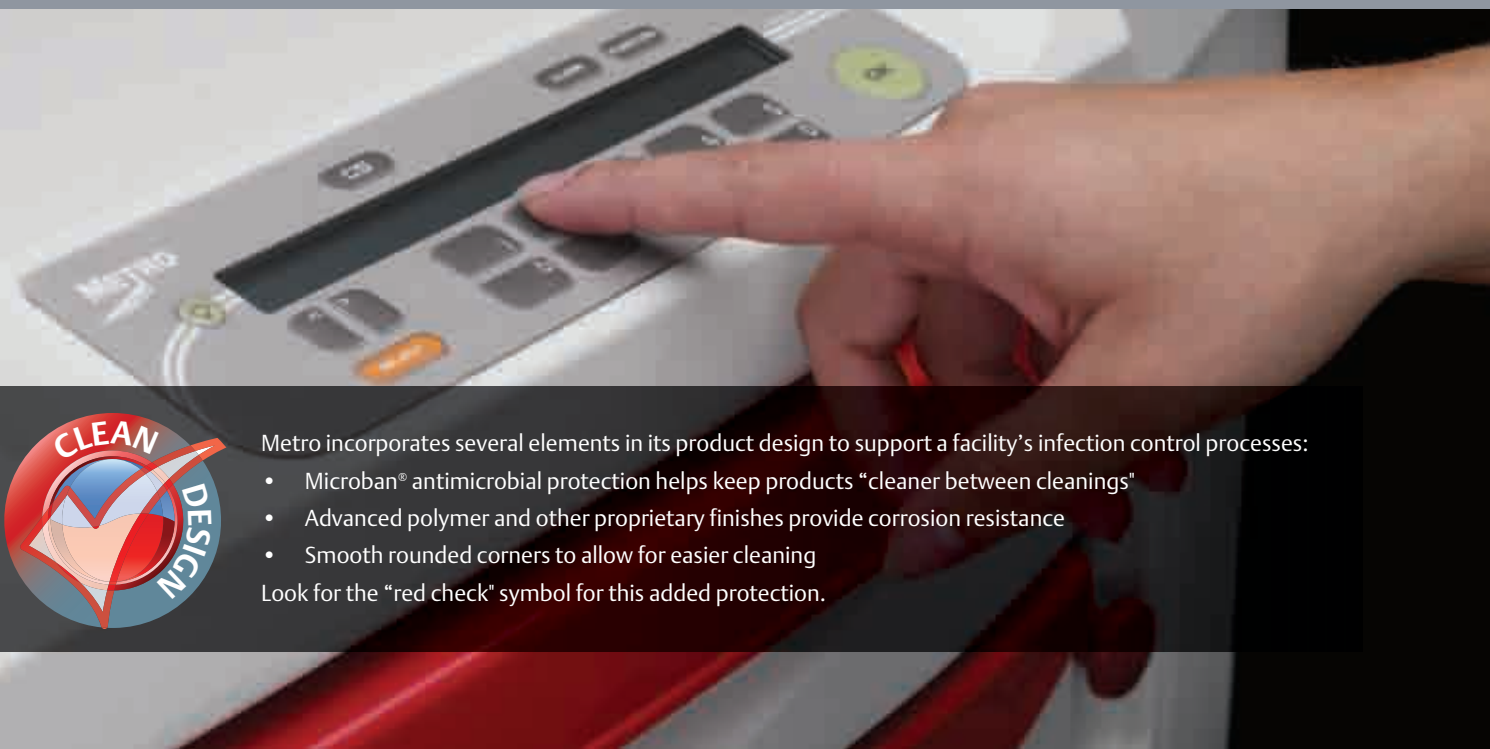

Metro incorporates several elements in its product design to support a facility's infection control processes:

- Microban® antimicrobial protection helps keep products “cleaner between cleanings”
- Advanced polymer and other proprietary finishes provide corrosion resistance
- Smooth rounded corners to allow for easier cleaning

Look for the “red check” symbol for this added protection.

# Standardized options. Configured by you.



## DRAWER PULL COLORS



## CODE CART DRAWER PULL COLOR



## PEDIATRIC COLOR KIT

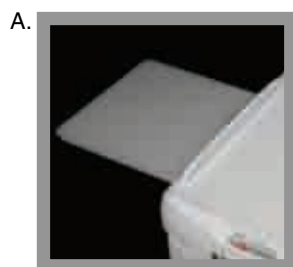

- > Advanced polymer construction, rounded corners and Microban antimicrobial product protection help maintain a cleaner cart to improve infection control.
- A. Pull out side shelf provides additional work space.
- B. Pull out interior shelf accommodates equipment or used as a seated writing surface.
- C. Laptop arm and keyboard shelf accommodate technology needs.
- D. Full extension drawers have self-closing ball bearing slides to provide easy access to medications and supplies. (Drawer depths: 3", 6", 9", 12")
- E. Auto Lock Keyless Entry Touchpads, Card Readers, Data Manager Software, Key Locks and Passive Locks are available for every security need.
- F. Spacious work surface provides a smooth writing surface or ample space for prep work.
- G. 5" (127mm) polymer caster, 2 directional and 2 total lock casters provide control and stability.
- H. Overbridge Storage creates additional space and clears clutter without expanding the cart footprint.
- I. Recessed side storage holds tilt out bins, wastebaskets, lockable sharps containers, O<sub>2</sub> tanks, glove boxes, and suction pump shelves.
- J. Strapless defibrillator platform adjusts to fit various defibrillators and can be moved away from work surface and towards the patient.
- K. The backboard can be mounted to the front or back of the cart.
- L. Passive security seals for the entire cart or individual drawers.

# FLEXLINE CARTS



Packages include carts and accessories.



Cat. No. **FLCRP1**  
Code Response Package



Cat. No. **FLCRP4**  
Code Response Package



Cat. No. **FLPED1**  
Pediatric Code Response



Cat. No. **FLANES1**  
Anesthesia Package



Cat. No. **FLISO1**  
Isolation Package



Cat. No. **FLISO3**  
Isolation Package



Cat. No. **FLBED**  
Bedside Package



Cat. No. **FLTMENT1**  
Treatment Package



Cat. No. **FLTMENT2**  
Treatment Package

Packages include carts and accessories.



Cat. No. **FLPROC1**  
Procedure Package



Cat. No. **FLPROC2**  
Procedure Package



Cat. No. **FLCAST**  
Cast Package



Cat. No. **FLENDO**  
Endoscopic Package



Cat. No. **FLDRS**  
Dressing Package



Cat. No. **FLIV**  
Phlebotomy Package

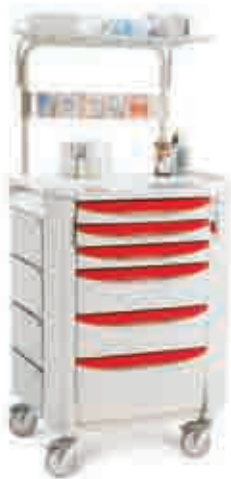

Cat. No. **FLCCU1**  
Critical Care Package



Cat. No. **FLAIR**  
Airway Package



Cat. No. **FLNURSE**  
Nurse Server Package

To configure a Flexline cart to your exact specifications, please visit [www.metroconfigurator.com](http://www.metroconfigurator.com)

Flexline Application-Specific Carts

Carts shown on the previous pages are configured with the components and accessories listed here.

Accessories

Cat. No.	Description	FLCRP1	FLCRP2	FLCRP3	FLCRP4	FLPED1	FLANES1	FLUS01	FLUS02	FLUS03	FLIBED	FLTMENT1	FLTMENT2	FLPROC1	FLPROC2	FLCOM-LT	FLCAST	FLEND0	FLDRS	FLIV	FLCCU1	FLCCU2	FLMDSRG	FLCLINE	FLAIR	FLNURSE
FL113	3" (76mm) Drawer Divider Kit						1			1			2	3	1			2	2			1		2	1	1
FL116	6/9" (152-229mm) Drawer Divider Kit						2			3			2					1	1	2		1		1	1	
FL131	Ampule Insert & 12 Divider for 3" (76mm) Drawer Tray														1					1						
FL151	3" (76mm) Drawer Divider Tray with Dividers	2	3	2	3															1						
FL159	6" (152mm) Drawer Divider Tray with Dividers	1	1	2	2																					
FL211	Side Bin (1) — Locking	2		3	4													3			4	3	3	2		
FL212	Side Bin (1) — Non-Locking						4	2						3	3	3	4	3	4		4	3	1	2	3	2
FL221	Waste Basket 28 Quart & Holder						X										X		X				X			
FL234	O <sub>2</sub> Tank Holder — Low	X	X																							
FL235	O <sub>2</sub> Tank Holder — High				X	X					X															
FL237	Glove Box Holder — Triple									X																
FL251	Lockable Sharps Container		X				X								X					X			X	X		
FL302	Cord Manager		X	X	X										X											
FL303	Defibrillator Strap Kit		X																							
LEC304	Adjustable Defibrillator Tray	X		X	X																					
FL305-4US	Hospital Grade 4-Outlet Strip and Holder	X	X	X	X									X				X				X				
LEC306	Suction Pump Shelf			X	X	X																				
LEC308	Backboard with Front Assembly Kit	X																								
LEC309	Backboard with Back Assembly Kit		X	X	X	X																				
FL310	Articulating Arm — Laptop															X										
FL318	Articulating Arm — Monitor																	X								
FL313	Peel Pouch/Catheter Holder						X																			
FL314	Pull Out Side Shelf			X	X	X				X					X		X	X				X	X			
FL315	2HK I.V. Pole with Cart Mount	X	X	X	X	X		X		X					X						X					
FL317	4HK I.V. Pole with Cart Mount																									
LEC320	Plastic Security Seals 100 Pack	X	X	X	X	X																				
FL402	Individual Drawer Seal Lock Bar — Flex 42" Cart			X																						
FL403	Individual Drawer Seal Lock Bar — Flex 45" Cart					X																				
FL411	Basic Keyless Entry Touchpad with Auto Lock Rechargeable											X								X					X	
FL420	Touchpad with LCD Screen, Auto Lock, USB Port						X							X	X	X		X			X		X	X		
FL510	Overbridge with 2 Hanger Rails						X							X												
FL515	Overbridge with Top Shelf and Hanger Rail														X						X	X	X			
FL520	Overbridge with 2 Shelves																X									
FL544	Tilt Bin 4 for Overbridge						X																			
FL546	Tilt Bin 6 for Overbridge						X														X					
FL581	Half-Size Utility Bin													X												
FL583	Label/Tape Dispenser													X												
FL585	Wire Supply Basket														X							X				
FL586	Utility Bin With Cover													X								X				

Carts

Cat. No.	Description	FL-OB	FL-OB	FL-OB	FL-OB	FL-PED9	FL-SB	FL-YL	FL-YL	FL-VL	FL-GR	FL-SB	FL-SB	FL-TPE	FL-SB	FL-OR	FL-GR	FL-SB	FL-RD	FL-RD	FL-RD	FL-GR	FL-TPE	FL-SB	FL-VL	
FL21P	36" (914mm) Cart — Passive Lock	X						X																		X
FL24P	39" (991mm) Cart — Passive Lock		X																							
FL27P	42" (1067mm) Cart — Passive Lock			X																						
FL30P	45" (1143mm) Cart — Passive Lock				X	X										X										
FLN24P	39" (991mm) Narrow Cart — Passive Lock									X																
FL24K	39" (991mm) Cart — Key Lock												X													
FL27K	42" (1067mm) Cart — Key Lock													X	X		X								X	
FL30K	45" (1143mm) Cart — Key Lock						X																			
FLN21K	36" (914mm) Narrow Cart — Key Lock										X	X														
FLN27K	42" (1067mm) Narrow Cart — Key Lock											X														
FLN30K	45" (1143mm) Narrow Cart — Key Lock											X														
FL-	Drawer Pull Color																									

Drawers

Cat. No.	Description	FL101	FL102	FL103EL	FL103	FL106	FL109	FL112
FL101	3" (76mm) Pull Out Shelf							
FL102	Keyboard Tray							
FL103EL	3" (76mm) Narcotics Box/Individual Locking Drawer							
FL103	3" (76mm) Drawer	2	3	4	3	8	2	1
FL106	6" (152mm) Drawer	1	1	1	2	1	2	2
FL109	9" (229mm) Drawer	1	1	1	1	1	1	3
FL112	12" (305mm) Drawer							

## Optional Technology

### Features Include:

- Articulating arm options to hold laptops, tablets, LCD monitors, and all-in-one computers
- Overbridge computer/monitor mounting options
- Retractable keyboard tray
- Premium power supply supporting all-in-one computers
- Internal/external wire management protects cords from snags and damage
- Tech trays for battery or computer storage
- Automatic electronic locking systems



Cat. No. **FLCOM-LT**  
Computer Package  
(Laptop, mouse, and power supply not included.)



Cat. No. **FLTMENT-KL**  
Computerized  
Treatment Package

Many applications in healthcare today are utilizing a form of technology. Applications that are integrating technology into their process need a cart that can accommodate those components. The needs can range from a simple hospital grade strip and articulating laptop arm, to a fully integrated solution with onboard power and a full complement of technology accessories.

## Build-a-Cart

### Cart Bodies without Drawers

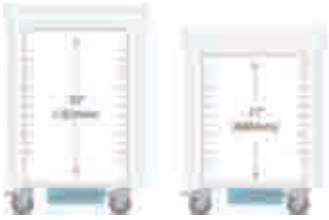

Nominal dimensions shown above

Width/Length/Height (in.)	Width/Length/Height (mm)	Drawer Space (in.)	Drawer Space (mm)	Lock	Battery	Keyboard Mount	Width	Cat. No.
22 <sup>3</sup> / <sub>8</sub> x32 <sup>1</sup> / <sub>4</sub> x41 <sup>7</sup> / <sub>8</sub>	568x819x1064	24	610	Key Lock	Li-Nano	Keyboard Tray	Standard	<b>FL27K-KL**</b>
23 <sup>3</sup> / <sub>8</sub> x32 <sup>1</sup> / <sub>4</sub> x45 <sup>1</sup> / <sub>4</sub>	568x819x1149	27	686	Key Lock	Li-Nano	Keyboard Tray	Standard	<b>FL30K-KL**</b>

\*Powered carts support all-in-one computers.

\*\*Powered cart shells come with a keyboard tray.

### Drawers

Description	Cat. No.
3" (76mm) Individual Locking Drawer for Narcotics Storage — Key Lock Cart	<b>FL103KL*<sup>F</sup></b>
3" (76mm) Individual Locking Drawer for Narcotics Storage — Electronic Lock Cart	<b>FL103EL*<sup>F</sup></b>
3" (76mm) Drawer (No Drawer Pull)	<b>FL103*</b>
6" (152mm) Drawer (No Drawer Pull)	<b>FL106*</b>
9" (229mm) Drawer (No Drawer Pull)	<b>FL109*</b>
12" (305mm) Drawer (No Drawer Pull)	<b>FL112*</b>

\*Flexline standard drawer pull colors available.

<sup>F</sup>Must be factory installed prior to shipment.

### Power Converters

Description	Cat. No.
Power Converter (12V Output)	<b>FLCNVTR-12</b>
Power Converter (19V Output)	<b>FLCNVTR-19</b>
Power Converter (24V Output)	<b>FLCNVTR-24</b>



FL505

### Power Cord

Description	Cat. No.
Starsys/Flexline 8' (2.4m) Power Cord — US	<b>SXFL-CORD-B</b>
Starsys/Flexline 8' (2.4m) Power Cord — Euro	<b>SXFL-CORD-C</b>
Starsys/Flexline 8' (2.4m) Power Cord — UK	<b>SXFL-CORD-G</b>
Starsys/Flexline 8' (2.4m) Power Cord — Swiss	<b>SXFL-CORD-J</b>
Starsys/Flexline 8' (2.4m) Power Cord — Aus	<b>SXFL-CORD-I</b>



FL319

### Power Tip Kits

Description	Cat. No.
DC Power Cable, 5.5mmx2.5mmx5.5mmx2.1mmx42" Long	<b>SXFL-TIP-01</b>
DC Power Cable, 5.5mmx2.5mmx5.5mmx2.5mmx42" Long	<b>SXFL-TIP-02</b>
DC Power Cable, 5.5mmx2.5mmx4.65mmx1.65mmx42" Long	<b>SXFL-TIP-03</b>
DC Power Cable, 5.5mmx2.5mmx7.9mmx5.5.4mmx42" Long	<b>SXFL-TIP-04</b>
DC Power Cable with Center Pin, 5.5mmx2.5mmx7.4mmx5mmx42" Long	<b>SXFL-TIP-05</b>
DC Power Cable, 5.5mmx2.5mmx4.65mmx1.65mmx42" Long	<b>SXFL-TIP-06</b>

### Computer and Computer Accessories

Description	Cat. No.
Hub, 4 Port, Belkin — Black	<b>SXFLUSBHUB</b>
Mouse, Optical, USB	<b>SXFLMOUSEUSB</b>
Keyboard, iRocks Ultra X-Slim	<b>SXFLKBRDA</b>
Cover, Keyboard, iRocks Antimicrobial	<b>SXFLKBRDACVR</b>
Tangent Vita 2001SA All-in-One Computer	<b>FLAIO</b>



SXFLKBRDA

### Computer Mounting Options

Description	Cat. No.
Monitor Arm Mounting (16-26 lbs.)	<b>FL319</b>
Overbridge Computer/Monitor Mounting Kit (Overbridge, Rail, Bracket & Cord Holder)	<b>FL505</b>



Flexline™ Carts with Power and Technology provides clinicians with real time access to information with the added benefits of:

- Smaller footprint for tighter spaces and easier maneuvering
- Highly configurable drawers
- Built in Microban® antimicrobial product protection



Computerized Anesthesia Package  
Cat. No. **FLANES-KL**



Computerized Treatment Package  
Cat. No. **FLTMENT-KL**

## Accessories

Cat. No.	Description	FLANES-KL	FLTMENT-KL
<b>FL420</b>	Lock Alert VI — Auto Lock	X	X
<b>FL113</b>	3" Drawer Divider Kit	1	
<b>FL116</b>	6/9" Drawer Divider Kit	2	
<b>FL211</b>	Side Bin (1) — Locking		3
<b>FL212</b>	Side Bin (1) — Non Locking	4	1
<b>FL251</b>	Lockable Sharps Container	X	X
<b>FL313</b>	Peel Pouch/Catheter Holder	X	
<b>FL314</b>	Pull Out Side Shelf		X
<b>FL546</b>	Tilt Bin 6 For Overbridge	1	
<b>FL505</b>	Flexline Overbridge Computer/Monitor Mounting Kit (Overbridge, Rail, Bracket, & Cord Extrusion)	1	1

## Computer Accessories

Cat. No.	Description	FLANES-KL	FLTMENT-KL
<b>FLAIO</b>	Tangent Vita 2000SA All-in-One Computer	X	X
<b>FLCNVTR-19</b>	Power Converter (19V Output)	X	X
<b>SXFL-TIP-01</b>	Power Tip Kit, 5.5mm x 2.5mm x 5.5mm x 2.1mm x 42" Long	X	X
<b>SXFL-CORD-B</b>	US Power Cord	X	X
<b>SXFLKBRDA</b>	Keyboard, iRocks Ultra X-Slim	X	X
<b>SXFLMOUSEUSB</b>	Mouse, Optical, USB	X	X
<b>SXFLKBRDACVR</b>	Keyboard, Cover, iRocks, Antimicrobial	X	X

## Carts

Cat. No.	Description	FLANES-KL	FLTMENT-KL
<b>FL27K-KL</b>	Flexline 42" (1067mm) Cart, Key Lock, Keyboard Tray and Lithium Nano Power		X
<b>FL30K-KL</b>	Flexline 45" (1067mm) Cart, Key Lock, Keyboard Tray and Lithium Nano Power	X	
<b>FL-</b>	Drawer Pull Color	FL-SB	FL-GR

## Drawers

Cat. No.	Description	FLANES-KL	FLTMENT-KL
<b>FL103EL</b>	3" Narcotics Box/Individual Locking Drawer	1	
<b>FL103</b>	3" FL Drawer — No Drawer Pull	1	2
<b>FL106</b>	6" FL Drawer — No Drawer Pull	2	3
<b>FL109</b>	9" FL Drawer — No Drawer Pull	1	

To configure a Flexline cart to your exact specifications, please visit [www.metroconfigurator.com](http://www.metroconfigurator.com)

Basic Carts with Drawers



FLNK22100

Cart	Drawer Configuration	Lock	Drawer Pull Color	Cat. No.
36" (914mm)H Standard	2 - 3" (76mm)	Key Lock	Violet	FLK21100
	1 - 6" (152mm)			
	1 - 9" (229mm)			
36" (914mm)H Narrow	3 - 3" (76mm)	Key Lock	Pink	FLNK32000
	2 - 6" (152mm)			
39" (991mm)H Standard	3 - 3" (76mm)	Passive Lock	Red	FLP31100
	1 - 6" (152mm)			
	1 - 9" (229mm)			
42" (1067mm)H Narrow	2 - 3" (76mm)	Key Lock	Slate Blue	FLNK22100
	2 - 6" (152mm)			
	1 - 9" (229mm)			
42" (1067mm)H Standard	4 - 3" (76mm)	Passive Lock	Slate Blue	FLP41100
	1 - 6" (152mm)			
	1 - 9" (229mm)			
42" (1067mm)H Narrow	3 - 9" (229mm)	Key Lock	Dark Taupe	FLNK00300
	2 - 6" (152mm)			
45" (1143mm)H Standard	2 - 3" (76mm)	Passive Lock	Orange	FLP22010
	2 - 6" (152mm)			
	1 - 12" (305mm)			
45" (1143mm)H Narrow	1 - 3" (76mm)	Passive Lock	Green	FLNP13100
	3 - 6" (152mm)			
	1 - 9" (229mm)			

Build-a-Cart

STANDARD CART

NARROW CART

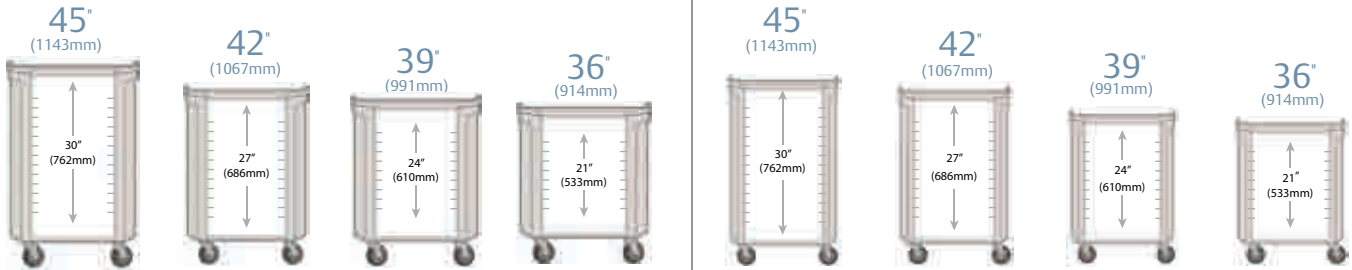

Nominal dimensions shown above

Cart Bodies without Drawers

Width/Length/Height (in.)	(mm)	Drawer Space		Lock	Width	Cat. No.
		(in.)	(mm)			
22 <sup>3</sup> / <sub>8</sub> x 32 <sup>1</sup> / <sub>4</sub> x 35 <sup>1</sup> / <sub>8</sub>	568 x 819 x 892	21	533	Passive Lock	Standard	FL21P
22 <sup>3</sup> / <sub>8</sub> x 32 <sup>1</sup> / <sub>4</sub> x 38 <sup>1</sup> / <sub>2</sub>	568 x 819 x 978	24	610	Passive Lock	Standard	FL24P
22 <sup>3</sup> / <sub>8</sub> x 32 <sup>1</sup> / <sub>4</sub> x 41 <sup>7</sup> / <sub>8</sub>	568 x 819 x 1064	27	686	Passive Lock	Standard	FL27P
22 <sup>3</sup> / <sub>8</sub> x 32 <sup>1</sup> / <sub>4</sub> x 45 <sup>1</sup> / <sub>4</sub>	568 x 819 x 1149	30	762	Passive Lock	Standard	FL30P
22 <sup>3</sup> / <sub>8</sub> x 28 <sup>7</sup> / <sub>8</sub> x 35 <sup>1</sup> / <sub>8</sub>	568 x 734 x 892	21	533	Passive Lock	Narrow	FLN21P
22 <sup>3</sup> / <sub>8</sub> x 28 <sup>7</sup> / <sub>8</sub> x 38 <sup>1</sup> / <sub>2</sub>	568 x 734 x 978	24	610	Passive Lock	Narrow	FLN24P
22 <sup>3</sup> / <sub>8</sub> x 28 <sup>7</sup> / <sub>8</sub> x 41 <sup>7</sup> / <sub>8</sub>	568 x 734 x 1064	27	686	Passive Lock	Narrow	FLN27P
22 <sup>3</sup> / <sub>8</sub> x 28 <sup>7</sup> / <sub>8</sub> x 45 <sup>1</sup> / <sub>4</sub>	568 x 734 x 1149	30	762	Passive Lock	Narrow	FLN30P
22 <sup>3</sup> / <sub>8</sub> x 32 <sup>1</sup> / <sub>4</sub> x 35 <sup>1</sup> / <sub>8</sub>	568 x 819 x 892	21	533	Key Lock	Standard	FL21K
22 <sup>3</sup> / <sub>8</sub> x 32 <sup>1</sup> / <sub>4</sub> x 38 <sup>1</sup> / <sub>2</sub>	568 x 819 x 978	24	610	Key Lock	Standard	FL24K
22 <sup>3</sup> / <sub>8</sub> x 32 <sup>1</sup> / <sub>4</sub> x 41 <sup>7</sup> / <sub>8</sub>	568 x 819 x 1064	27	686	Key Lock	Standard	FL27K
22 <sup>3</sup> / <sub>8</sub> x 32 <sup>1</sup> / <sub>4</sub> x 45 <sup>1</sup> / <sub>4</sub>	568 x 819 x 1149	30	762	Key Lock	Standard	FL30K
22 <sup>3</sup> / <sub>8</sub> x 28 <sup>7</sup> / <sub>8</sub> x 35 <sup>1</sup> / <sub>8</sub>	568 x 734 x 892	21	533	Key Lock	Narrow	FLN21K
22 <sup>3</sup> / <sub>8</sub> x 28 <sup>7</sup> / <sub>8</sub> x 38 <sup>1</sup> / <sub>2</sub>	568 x 734 x 978	24	610	Key Lock	Narrow	FLN24K
22 <sup>3</sup> / <sub>8</sub> x 28 <sup>7</sup> / <sub>8</sub> x 41 <sup>7</sup> / <sub>8</sub>	568 x 734 x 1064	27	686	Key Lock	Narrow	FLN27K
22 <sup>3</sup> / <sub>8</sub> x 28 <sup>7</sup> / <sub>8</sub> x 45 <sup>1</sup> / <sub>4</sub>	568 x 734 x 1149	30	762	Key Lock	Narrow	FLN30K



FL420

### Additional Security

Description	Cat. No.
Individual Drawer Seal Lock Bar — 36" (914mm) Cart	FL400 <sup>F</sup>
Individual Drawer Seal Lock Bar — 39" (991mm) Cart	FL401 <sup>F</sup>
Individual Drawer Seal Lock Bar — 42" (1067mm) Cart	FL402 <sup>F</sup>
Individual Drawer Seal Lock Bar — 45" (1143mm) Cart	FL403 <sup>F</sup>
Basic Keyless Entry Touchpad with 10 Year Battery	FL410 <sup>*F</sup>
Basic Keyless Entry Touchpad with Auto Lock, Rechargeable	FL411 <sup>*F</sup>
Touchpad Charger Adapter Kit — Must use outside of North America <sup>††</sup>	FL419A <sup>F</sup>
Touchpad with LCD Screen, Auto Lock, USB Port (Card Reader Upgradable)	FL420 <sup>*F</sup>
Software Manager for FL420	FL421
Proximity Card Reader for FL420 (Compatible with HID 125KHz and Farpointe)	FL430 <sup>**F</sup>
Bar Code Card Reader for FL420	FL431 <sup>**F</sup>
Magnetic Card Reader for FL420	FL432 <sup>**F</sup>

<sup>\*</sup>FL410, FL411, FL420 can only be ordered with a key locking cart.  
<sup>\*\*</sup>Readers may not be compatible with all cards. A sample card must be submitted to verify compatibility. Contact your Metro representative.  
<sup>††</sup>Must be factory installed prior to shipment.  
<sup>†††</sup>90-264 VAC 47-63 Hz



FL400-FL403



FL101

### Drawer, Shelf and Keyboard Shelf Drawer pulls must be ordered with each drawer.

Description	Cat. No.
Lockable Drawer Cover	FL100 <sup>F</sup>
3" (76mm) Pull Out Shelf	FL101
Keyboard Tray	FL102 <sup>F</sup>
3" (76mm) Individual Locking Drawer for Narcotics Storage — Key Lock Cart	FL103KL <sup>F</sup>
3" (76mm) Indiv. Locking Drawer for Narcotics Storage — Electronic Lock Cart	FL103EL <sup>F</sup>
3" (76mm) Drawer (No Drawer Pull)	FL103
6" (152mm) Drawer (No Drawer Pull)	FL106
9" (229mm) Drawer (No Drawer Pull)	FL109
12" (305mm) Drawer (No Drawer Pull)	FL112
Solid Bottom Shelf	FL120
Pediatric Code Response Drawer Kit (8-3", 1-6" Drawers with colored pulls)	FL-PED9 <sup>**</sup>

<sup>\*</sup>Inside Drawer Dimensions — 20 1/4" (514mm) wide x 17" (432mm) deep; Heights: 2 3/4" (70mm), 5 3/4" (146mm), 8 1/2" (222mm) 11 1/4" (298mm).  
<sup>\*\*</sup>Can only be ordered with a 45" cart.  
<sup>††</sup>Must be factory installed prior to shipment.



FL102

### Drawer Pulls Colors Order 1 drawer pull per drawer.

Description	Cat. No.
Drawer Pull — Cobalt	FL-CB
Drawer Pull — Red	FL-RD
Drawer Pull — Orange	FL-OR
Drawer Pull — Green	FL-GR
Drawer Pull — Yellow	FL-YL
Drawer Pull — Slate Blue	FL-SB
Drawer Pull — Violet	FL-VL
Drawer Pull — Pink	FL-PK
Drawer Pull — White	FL-WHT
Drawer Pull — Dark Taupe	FL-TPE



FL-PED9

### DRAWER PULL COLORS

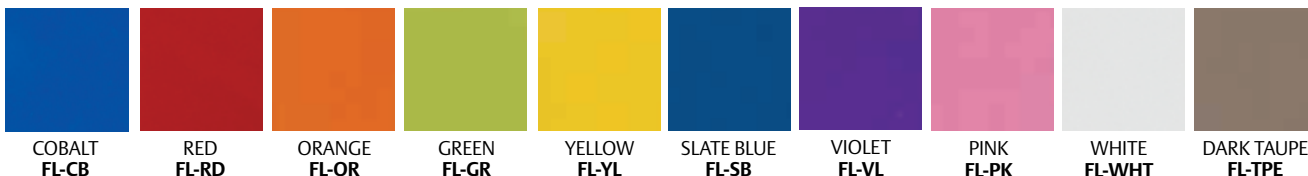

COBALT FL-CB    RED FL-RD    ORANGE FL-OR    GREEN FL-GR    YELLOW FL-YL    SLATE BLUE FL-SB    VIOLET FL-VL    PINK FL-PK    WHITE FL-WHT    DARK TAUPE FL-TPE

To configure a Flexline cart to your exact specifications, please visit [www.metroconfigurator.com](http://www.metroconfigurator.com)



FL151



FL159



FL190 (Label not included)

### Drawer Accessories



FL237



FL235



FL236, FL221



FL212

Description	Cat. No.
Divider Clip to Attach Loose Short Divider-end to Long Divider, 1 per Short Divider (Qty. 2)	T-CLIP
3" (76mm) Drawer Divider Kit (3 Long, 5 Short, 6 T-Clips)	FL113
Short Divider for LEC103 or FL103 5 Pack 6 <sup>7</sup> / <sub>8</sub> " L (175mm)	FL114
Long Divider for LEC103 or FL103 2 Pack 17 <sup>1</sup> / <sub>4</sub> " L (437mm)	FL115
6/9" (152/229mm) Drawer Divider Kit (2 Long, 5 Short)	FL116
Short Divider for LEC106 or FL106 5 Pack 8" L (205mm)	FL117
Long Divider for LEC106 or FL106 2 Pack 17 <sup>1</sup> / <sub>4</sub> " L (437mm)	FL118
Ampule Insert and 12 Divider for Top Cavity or 3" (76mm) Drawer Tray 15 <sup>3</sup> / <sub>4</sub> " x 4 <sup>7</sup> / <sub>8</sub> " (400 x 124mm)	FL131
Divider for FL131, 12 Pack 5" L (125mm)	FL132
3" (76mm) Egg Crate-Style Drawer Divider Kit (Qty. 10 Vertical, 5 Horizontal)	FL141
6" (152mm) Egg Crate-Style Drawer Divider Kit (Qty. 10 Vertical, 5 Horizontal)	FL142
Short Divider for FL141 — Qty. 5 each 10" L (256mm)	FL143
Long Divider for FL141 — Qty. 5 each 17 <sup>1</sup> / <sub>8</sub> " L (436mm)	FL144
Short Divider for FL142 — Qty. 5 each 10" L (256mm)	FL145
Long Divider for FL142 — Qty. 5 each 17 <sup>1</sup> / <sub>8</sub> " L (436mm)	FL146
3" (76mm) Drawer Tray Approx. 20" x 16" (508 x 381mm) with 6 Dividers 4 Short, 2 Long, Sheet of Blank Labels, 5 Security Bags	FL151
Lid for 3" and 6" (76mm and 152mm) Drawer Tray (Fits FL151 and FL159)	FL158
6" (152mm) Drawer Tray Approx. 19" x 15" (483 x 381mm) with Dividers 6 Short, 2 Long, 5 Security Bags	FL159
Long Divider Rails for LEC143 or FL151 2 Pack 15 <sup>1</sup> / <sub>2</sub> " L (394mm)	FL163
Short Divider for LEC143 or FL151 10 Pack 6 <sup>7</sup> / <sub>8</sub> " L (175mm)	FL164
Long Divider for FL159 (2 Pack) 14 <sup>3</sup> / <sub>4</sub> " L (375mm)	FL166
Short Divider for FL159 (3 Pack) 8" L (205mm)	FL167
Security Bags for 3" (76mm) Tray and 6" (152mm) Tray 20 Pack	FL183
Label Holder Set of 10 13 <sup>5</sup> / <sub>8</sub> " L (346mm)	FL190

### Side/Recessed Storage Accessories

Description	Cat. No.
Side Bin (1) — Locking 4 <sup>1</sup> / <sub>2</sub> " x 16 <sup>3</sup> / <sub>4</sub> " x 8 <sup>1</sup> / <sub>2</sub> " (117 x 426 x 216mm)	FL211*F
Side Bin (1) — Non-Locking 4 <sup>1</sup> / <sub>2</sub> " x 16 <sup>3</sup> / <sub>4</sub> " x 8 <sup>1</sup> / <sub>2</sub> " (117 x 426 x 216mm)	FL212
Waste Basket 28 Quart and Holder 14 <sup>1</sup> / <sub>2</sub> " x 10 <sup>7</sup> / <sub>8</sub> " x 15 <sup>3</sup> / <sub>8</sub> " (370 x 275 x 390mm)	FL221
Waste Basket 28 Quart	FL222
Bracket with Velcro for Waste Basket or Large Sharps Container	FL223
O <sub>2</sub> Tank Holder — All Size Carts — 5 <sup>1</sup> / <sub>2</sub> " (140mm) Diameter Tank	FL234-5
O <sub>2</sub> Tank Holder — All Size Carts — 4" (102mm) Diameter Tank	FL234
O <sub>2</sub> Tank Holder — 45" (1140mm)H Cart — 5 <sup>1</sup> / <sub>2</sub> " (140mm) Diameter Tank	FL235-5
9 <sup>3</sup> / <sub>8</sub> " x 5 <sup>1</sup> / <sub>2</sub> " x 19 <sup>1</sup> / <sub>4</sub> " (238 x 144 x 489mm)	
O <sub>2</sub> Tank Holder — 45" (1140mm)H Cart — 4" (102mm) Diameter Tank	FL235
9 <sup>3</sup> / <sub>8</sub> " x 6 <sup>3</sup> / <sub>4</sub> " x 19 <sup>1</sup> / <sub>4</sub> " (238 x 172 x 489mm)	
Glove Box Holder — Single 4" x 10 <sup>1</sup> / <sub>8</sub> " x 6 <sup>3</sup> / <sub>8</sub> " (101 x 258 x 162mm)	FL236
Glove Box Holder — Triple 4" x 10 <sup>1</sup> / <sub>8</sub> " x 18 <sup>3</sup> / <sub>8</sub> " (101 x 258 x 466mm)	FL237
Scope Cabinet, 2 — Hook 10 <sup>3</sup> / <sub>8</sub> " x 9" x 48" (264 x 229 x 1219mm)	FL245**
Scope Cabinet, 4 — Hook 10 <sup>3</sup> / <sub>8</sub> " x 16" x 48" (264 x 406 x 1219mm)	FL246**
Sharps Container Bracket with Velcro® Straps — Non-Locking 9 <sup>1</sup> / <sub>2</sub> " x 3 <sup>1</sup> / <sub>4</sub> " x 9 <sup>5</sup> / <sub>16</sub> " (241 x 83 x 237mm)	FL250
Lockable Sharps Container 4 <sup>3</sup> / <sub>4</sub> " x 13" x 19 <sup>7</sup> / <sub>8</sub> " (with Glove Box) x 11 <sup>3</sup> / <sub>8</sub> " (without Glove Box) (121 x 330 x 505 or 302mm)	FL251
Replacement Containers for FL251 — 20 5 Qt. containers	FL252

\*Locking bins for keylock cart are available on the right. Locking bins for the passive lock cart are available on the left.

\*\*Must be factory installed prior to shipment.

\*\*For use on 45" H (1143mm) carts only.



FL314







LEC304, FL315



FL303

### Cart Accessories

Description	Cat. No.
Rear Accessory Mount Brackets — 1 Pair	FL301 <sup>F</sup>
Cord Manager 1/2" x 21 3/4" x 1 1/4" (13 x 554 x 31mm)	FL302
Defibrillator Strap Kit	FL303
Adjustable Defibrillator Tray 8 1/8"-14 1/4" x 14 1/2" (206-362 x 368mm)	LEC304
Hospital Grade 4-Outlet Strip, 120V 15A, UL60601-01, 10' Cord, Cord Wrap	FL305-4US
Universal 6 Outlet Power Strip, 250 V 13A, CE, ROHS, 6' (183cm) Cord, Cord Wrap	See Below
 FL305-EU UNIVERSAL	
 FL305-AUS UNIVERSAL	
 FL305-UK UNIVERSAL	
 FL305-IT UNIVERSAL	
 FL305-4-US HOSPITAL GRADE	
Suction Pump Shelf 12 1/2" x 15 1/4" x 4 1/4" (320 x 384 x 108mm)	LEC306
Backboard with Front and Rear Assembly Kit	LEC307 <sup>F</sup>
Backboard with Front Assembly Kit	LEC308 <sup>F</sup>
Backboard with Back Assembly Kit	LEC309 <sup>F</sup>
Backboard with Rear Assembly Kit for use with an Overbridge	FL309-OB
Backboard with Back Assembly Kit for 36"H (914mm) FL21 Series Cart	FL309-21 <sup>F†</sup>
Backboard with Rear Assembly Kit for use with 36"H FL621 Series Cart with Overbridge	FL309-21OB
Articulating Arm — Laptop 10	FL310
Articulating Arm — Tablet	FL311
Articulating Arm — Monitor 8.5-16.5 lb. (3.9-7.5kg) Weight Load	FL318
Articulating Arm — Monitor 16-26 lbs.	FL319
Peel Pouch Container 3" x 6" x 18 1/4" (78 x 154 x 461mm)	FL312
Peel Pouch/Catheter Holder 3" x 6" x 27 3/8" (78 x 154 x 695mm)	FL313
Pull Out Side Shelf 12 1/2" x 30 1/2" x 3 9/8" (322 x 775 x 10mm)	FL314 <sup>F</sup>
2HK I.V. Pole with Cart Mount 1/2" x 9 1/8" x 37" (max.)*-25 1/4" (min.)* (38 x 232 x 940-640mm)	FL315
4HK I.V. Pole with Cart Mount 5" x 7 1/8" x 37" (max.)*-25 1/4" (min.)* (127 x 183 x 940-640mm)	FL317
I.V. Pole-mounted Sharp Brackets	LEC9800
Plastic Security Seals 100 Pack	LEC320
Backboard 24"L x 24"H x 5/16" (610 x 610 x 8mm)	LEC323

<sup>F</sup>Must be factory installed.

\*Max., Min. in relation to cart top.

<sup>†</sup>Must be ordered on a 36"H (914mm) cart to accommodate I.V. pole, defibrillator arm, articulating arm or outlet strip.



FL310



FL310, FL311, FL318, FL319, FL312, FL313, FL314, FL315, FL317



FL505, FL510, FL515, FL520, FL543, FL546, FL550, FL559, FL560, FL563, FL566, FL570, FL571, FL574, FL575



FL576, FL581, FL582, FL583, FL584, FL585, FL586, FL590

### Overbridges and Overbridge Accessories

Description	Cat. No.
Overbridge with Computer/Monitor Mounting Kit	FL505
Overbridge with 2 Hanger Rails 1 1/4" x 26 1/8" x 19 7/8"-25 1/2" (32 x 665 x 504-649mm)	FL510
Overbridge with Top Shelf and Hanger Rail	FL515
Overbridge with 2 Shelves	FL520
Tilt Bin 3 for Overbridge — 9 1/2" (241mm)H x 7 3/4" (197mm)W x 23 3/4" (600mm)L	FL543
Tilt Bin 6 for Overbridge — 4 1/2" (114mm)H x 3 1/4" (92mm)W x 23 3/4" (600mm)L	FL546
Hanger Rail	FL550
Overbridge Bottom Shelf 14 1/2" x 31" (368 x 787mm)	FL559
Overbridge Top Shelf 14 1/2" x 31" (368 x 787mm)	FL560
2HK I.V. Pole With Universal Clamp — for Overbridge	FL563
4HK I.V. Pole With Universal Clamp — for Overbridge 9 1/8" x 28 1/4" x 19 7/8"-25 1/2" (232 x 718 x 504-649mm)	FL566
Universal Clamp	FL570
Short Utility Hook 4 Pack (Holds Peel Pouches, I.V. Bags, Stethoscopes, etc.)	FL571 <sup>*</sup>
4-Hook Rack (Holds Forceps and Scopes) 3 7/8" x 11" x 6" (98 x 282 x 151mm)	FL574
Laryngoscope Blade/Specimen Bag Holder (Holds Plastic Bag — Not Included — for Safe Storage of Contaminated Items) 3 3/4" x 7 1/2" x 5 1/8" (95 x 192 x 130mm)	FL575 <sup>*</sup>
Chart Holder 4 3/4" x 11 1/2" x 9 1/4" (120 x 292 x 235mm)	FL576
Half-Size Utility Bin — 5 1/2" (140mm)H x 5 1/2" (140mm)W x 5 3/4" (146mm)L	FL581
Full-Size Utility Bin — 5 1/2" (140mm)H x 5 1/2" (140mm)W x 11 3/4" (292mm)L	FL582
Label/Tape Dispenser	FL583
Sharps Bracket Container	FL584 <sup>*</sup>
Wire Supply Basket — 5" (127mm)H x 7" (178mm)W x 17" (432mm)L	FL585
Utility Bin with Cover (Pack of Six)	FL586
Monitor Mounts for Overbridge with Bracket for Overbridge	FL590

\*Fits on universal clamp in addition to a hanger rail.

To configure a Flexline cart to your exact specifications, please visit [www.metroconfigurator.com](http://www.metroconfigurator.com)



# Basix™

## BASIX OVERVIEW

### BASIX PLUS

### BASIX



## Basix Plus — all the basics plus lighter, cleaner, easier.

### CLEANER

Infection control: Cleanliness is improved by removing unsightly accessory holes found in traditional metal carts.

### LIGHTER

Lightweight aluminum drawers and polymer components make Basix Plus lighter and easier to move than typical all-steel carts.

### EASIER

Ergonomic push handles molded into the cart top minimize the cart's footprint and provide a natural location for maneuvering the cart. Side mounting channels allow for easy and flexible accessorization.

A color code must be included with each cart/drawer ordered. The color code determines the color of the drawer and on solid carts the color of the cart. The quantity should equal the total number of carts.



- |                                       |  |                                       |                                       |  |   |                                      |  |                                   |                                 |  |   |                                  |                                    |
|---------------------------------------|--|---------------------------------------|---------------------------------------|--|---|--------------------------------------|--|-----------------------------------|---------------------------------|--|---|----------------------------------|------------------------------------|
| Cat. No.<br><b>MB-BG</b><br>Blue Gray | Cat. No.<br><b>MB-CB</b><br>Crash Cart<br>Blue | Cat. No.<br><b>MB-CR</b><br>Cranberry | Cat. No.<br><b>MB-DB</b><br>Dark Blue | Cat. No.<br><b>MB-DT</b><br>Dark Taupe | Cat. No.<br><b>MB-HG</b><br>Hunter<br>Green | Cat. No.<br><b>MB-LA</b><br>Lavender | Cat. No.<br><b>MB-LT</b><br>Light<br>Taupe | Cat. No.<br><b>MB-MA</b><br>Mauve | Cat. No.<br><b>MB-RE</b><br>Red | Cat. No.<br><b>MB-SB</b><br>Slate Blue | Cat. No.<br><b>MB-SG</b><br>Sea Foam<br>Green | Cat. No.<br><b>MB-TE</b><br>Teal | Cat. No.<br><b>MB-YE</b><br>Yellow |
|---------------------------------------|--|---------------------------------------|---------------------------------------|--|---|--------------------------------------|--|-----------------------------------|---------------------------------|--|---|----------------------------------|------------------------------------|

### NEW CONTEMPORARY COLORS



# Traditional materials. Inspired design.

## DRAWER COLORS



- A. Touchpad and proximity reader feature auto re-lock and tamper-resistant programming.
- B. Pass thru shelf can be accessed from either side of the cart to maximize functionality.
- C. Self-closing ball bearing slides allow for smooth action of drawers to provide complete access to contents.
- D. Accessories including overbridge, extendible I.V. pole, and side storage allow supplies to be organized and easily accessible.
- E. Ergonomic polymer work surface has molded in handles to minimize cart footprint as well as a raised perimeter for spill containment.
- F. Polymer corner accessory channels improve cleanliness by eliminating dirt catching holes on sides and back of typical metal carts.
- G. Lightweight, full extension aluminum drawers make Plus lighter than all steel carts.
- H. Double-wall steel body with powder coated finish provides structural integrity.
- I. Polymer base reduces weight of cart and provides impact protection to cart and surroundings.



Cart packages include cart and accessories shown.

Code Response Cart  
Cat. No. **MBP3210CRT1**  
(Shown with optional MBP410)  
(Color Shown: MB-RE)



Accessory Package  
Cat. No. **MBPCR-1**

Code Response Cart  
Cat. No. **MBP3210CRT2**  
(Shown with optional MBP410)  
(Color Shown: MB-RE)



Accessory Package  
Cat. No. **MBPCR-2**

Pediatric Response Cart  
Cat. No. **MBP8100PEDS**  
with MBA235  
(Shown with optional lock bars)  
(Color Shown: MB-PED5)



Accessory Package  
Cat. No. **MBPCRPEDS**

Anesthesia Cart  
Cat. No. **MBP3210ANES1**  
(Color Shown: MB-CR)



Accessory Package  
Cat. No. **MBPANES-1**

Anesthesia Cart  
Cat. No. **MBP3210ANES2**  
(Color Shown: MB-LT)



Accessory Package  
Cat. No. **MBPANES-2**

Isolation Cart  
Cat. No. **MBP0120ISO**  
(Color Shown: MB-YE)



Accessory Package  
Cat. No. **MBPISO-1**

Endoscopic Cart  
Cat. No. **MBP0120ENDO**  
(Color Shown: MB-BG)



Accessory Package  
Cat. No. **MBPENDO-1**

Trauma Cart  
Cat. No. **MBP3210TRAUMA**  
with MBP410 Lock Bar  
(Color Shown: MB-MA)



Accessory Package  
Cat. No. **MBPED-1H**

General Cart  
Cat. No. **MBP1210GEN**  
(Color Shown: MB-DT)



Accessory Package  
Cat. No. **MBPBAS-1**

Accessory Packages

Cat. No./Description	Backboard	Corner Defib. Shelf	I.V. Pole	Plastic Seals	O <sub>2</sub> Tank Brackets	Side Accy. Brackets (2)	Waste Container	Suction Unit Shelf	3" (76mm) Tray with Dividers	Side Shelf	Cart Top Rail	Overbridge Shelf	Hanger Rail	Divided Organizer	Outlet Strips	Label Holders	4 Tilt Bins	5 Tilt Bins	6 Tilt Bins	Catheter Holder	Wire Basket	Glove Box Holder	Sharps Bracket	Coat Rack	Scope Holder (4)	Side Bins (3)
<b>MBPCR-1</b> Code Response Pkg. #1	1	1	1	1	1	1		1	1																	
<b>MBPCR-2</b> Code Response Pkg. #2	1			1	1					1	1															
<b>MBPCR-3</b> Code Response Pkg. #3	1			1	1	1		1				1-D**	1		1	1										
<b>MBPANES-1</b> Anesthesia Package #1				1			1	1			1		3*				1	1	1-28"	1						
<b>MBPANES-2</b> Anesthesia Package #2				1			1	1		1	1	1-N**	1					1				1	1			
<b>MBPISO-1</b> Isolation Package #1							1															1		1		
<b>MBPENDO-1</b> Endoscopic Package #1							1			1	1	2-N**		1											1	
<b>MBPED-1H</b> Trauma Package #1			1				1					1-N**	2		1		1	1	1			1	1			1
<b>MBPBAS-1</b> Basic Package #1				1			1	1		1												1	1			
<b>MBPCRPEDS</b> Pediatrics Package		1	1				1		1																	

\*Includes 1 rail with hooks.  
\*\*N = Narrow D = Deep

BASIX PLUS PEDIATRICS CARTS

Pediatric Carts — 24 1/8" W. x 30" L. (613x762mm)

45" (1143mm) High

Drawer Space	Drawer Configuration	Color	Lock	Approx. Pkd. Wt. (lbs.) (kg)		Cat. No.
30" (762mm)	8 - 3" (76mm) 1 - 6" (152mm)	Two Tone	Non Lock	151	72	<b>MBP8100TN</b>
30" (762mm)	8 - 3" (76mm) 1 - 6" (152mm)	Two Tone	Breakaway Lock	151	72	<b>MBP8100TB</b>

Note: Drawer color MB-PEDS quantity should equal the total number of carts.



Cart: MBP8100TN  
Color: MB-PEDS

Basic Carts — 24 1/8" W. x 30" L. (613x762mm)

Low Profile — 38 1/2" (978mm) High

Drawer Space	Drawer Configuration	Color	Lock	Approx. Pkd. Wt. (lbs.) (kg)		Cat. No.
24" (610mm)	3 - 3" (76mm) 1 - 6" (152mm) 1 - 9" (230mm)	Two Tone	None	151	72	<b>MBP3110TN*</b>
24" (610mm)	1 - 3" (76mm) 2 - 6" (152mm) 1 - 9" (230mm)	Two Tone	None	151	72	<b>MBP1210TN</b>
24" (610mm)	3 - 3" (76mm) 1 - 6" (152mm) 1 - 9" (230mm)	Two Tone	Breakaway Lock Bar	151	72	<b>MBP3110TB*</b>
24" (610mm)	3 - 3" (76mm) 1 - 6" (152mm) 1 - 9" (230mm)	Two Tone	Key Lock	151	72	<b>MBP3110TL*</b>
24" (610mm)	1 - 3" (76mm) 2 - 6" (152mm) 1 - 9" (230mm)	Two Tone	Key Lock	151	72	<b>MBP1210TL</b>
24" (610mm)	1 - 6" (152mm) 2 - 9" (230mm)	Two Tone	Key Lock	151	72	<b>MBP0120TL</b>



Cart: MBP0120TL  
Color: MB-BG (shown with optional accessories)

\*Also available in solid colors (cart body color matches drawer color).



Cat. No. **MBP3210TL**

**Basic Carts - 24<sup>1</sup>/<sub>8</sub>" (613mm)W x 30" (672mm)L**  
**High Profile — 45" (1440mm) High**

Drawer Space	Drawer Configuration	Color	Lock	Approx. Pkd. Wt. (lbs.) (kg)		Cat. No.
30" (762mm)	4 - 3" (76mm)	Two Tone	None	159	75	<b>MBP4101TN*</b>
	1 - 6" (152mm)					
	1 - 12" (304mm)					
30" (762mm)	3 - 3" (76mm)	Two Tone	None	159	75	<b>MBP3210TN*</b>
	2 - 6" (152mm)					
	1 - 9" (230mm)					
30" (762mm)	4 - 3" (76mm)	Two Tone	Breakaway Lock Bar	159	75	<b>MBP4101TB*</b>
	1 - 6" (152mm)					
	1 - 12" (304mm)					
30" (762mm)	4 - 3" (76mm)	Two Tone	Key Lock	159	75	<b>MBP4101TL*</b>
	1 - 6" (152mm)					
	1 - 12" (304mm)					
30" (762mm)	3 - 3" (76mm)	Two Tone	Key Lock	159	75	<b>MBP3210TL</b>
	2 - 6" (152mm)					
	1 - 9" (230mm)					

Note: Drawer color and solid cart body color is specified by ordering the desired color/code from page 190.

\*Also available in solid colors



Pass Thru Side Shelf  
 Cat. No. **MBP300**  
 (Listed on next page)

**Low Profile — 38<sup>1</sup>/<sub>2</sub>" (978mm) High**

Drawer Space	Drawer Configuration	Color	Lock	Width (in.) (mm)		Length (in.) (mm)		Cat. No.
24" (610mm)	Empty	Two Tone	None	24 <sup>1</sup> / <sub>8</sub>	613	30	762	<b>MBP24TN*</b>
24" (610mm)	Empty	Two Tone	Breakaway Lock Bar	24 <sup>1</sup> / <sub>8</sub>	613	30	762	<b>MBP24TB*</b>
24" (610mm)	Empty	Two Tone	Key Lock	24 <sup>1</sup> / <sub>8</sub>	613	30	762	<b>MBP24TL*</b>

**High Profile — 45" (1143mm) High**

Drawer Space	Drawer Configuration	Color	Lock	Width (in.) (mm)		Length (in.) (mm)		Cat. No.
30" (762mm)	Empty	Two Tone	None	24 <sup>1</sup> / <sub>8</sub>	613	30	762	<b>MBP30TN*</b>
30" (762mm)	Empty	Two Tone	Breakaway Lock Bar	24 <sup>1</sup> / <sub>8</sub>	613	30	762	<b>MBP30TB*</b>
30" (762mm)	Empty	Two Tone	Key Lock	24 <sup>1</sup> / <sub>8</sub>	613	30	762	<b>MBP30TL*</b>

\*Also available in solid colors



Pushbutton Lock  
 May be ordered with key locking carts only.  
 Cat. No. **MBA435**



Touchpad with Proximity Reader  
 May be ordered with key locking carts only.  
 Cat. No. **MBP445**

**Drawers**

Description	Wt. Capacity (lbs.) (kg)		Depth (in.) (mm)		Length (in.) (mm)		Height (in.) (mm)		Cat. No.
3" (76mm) Deep Aluminum Drawer	50	24	17	432	22 <sup>1</sup> / <sub>4</sub>	565	2 <sup>7</sup> / <sub>8</sub>	73	<b>MBP103</b>
6" (152mm) Deep Aluminum Drawer	50	24	17	432	22 <sup>1</sup> / <sub>4</sub>	565	6 <sup>1</sup> / <sub>4</sub>	159	<b>MBP106</b>
9" (230mm) Deep Aluminum Drawer	50	24	17	432	22 <sup>1</sup> / <sub>4</sub>	565	9 <sup>3</sup> / <sub>8</sub>	238	<b>MBP109</b>
12" (51mm) Deep Aluminum Drawer	50	24	17	432	22 <sup>1</sup> / <sub>4</sub>	565	12 <sup>1</sup> / <sub>4</sub>	311	<b>MBP112</b>

Note: Drawer color and solid cart body color is specified by ordering the desired color/code from page 190.

**Add Keyless Entry to any Basix Plus Cart**

Description	Cat. No.
Mechanical Pushbutton Lock	<b>MBA435</b>
Electronic Touchpad with Auto Lock and 100 User Codes	<b>MBP440</b>
Proximity Reader/Electronic Touchpad	<b>MBP445*</b>
(Compatible with Mifare 13.56MHz ISO14443A Cards)	
Retro-Fit Proximity Reader (Compatible with Mifare 13.56MHz ISO14443A Cards)	<b>MBP450*</b>
Proximity Card	<b>MBA441</b>
Proximity Sticker	<b>MBA442</b>
Proximity Key Fob	<b>MBA443</b>

\*Readers may not be compatible with all cards. A sample card must be submitted to verify compatibility. Contact your Metro representative.

Side Accessories — Basix Plus and Basix Plus Compact

Description	Dimensions		Approx. Pkd. Wt.		Cat. No.
	(in.)	Height/Width/Length (mm)	(lbs.)	(kg)	
Side Storage Unit 30"H. (762mm) with 3 Shelves	34 <sup>3</sup> / <sub>8</sub> x18x13 <sup>1</sup> / <sub>2</sub>	886x457x342	52	23.7	MBA200
Side Accessory Bracket (2 Pack)	4x18x <sup>1</sup> / <sub>4</sub>	102x457x6	1	.455	MBP205
Back Accessory Bracket (2 Pack)	4x26 <sup>1</sup> / <sub>4</sub>	102x643	2	.91	MBP207†
Push Handles (Pair)	—	—	1	.455	MBP209
3 Wide Glove Box Holder	16 <sup>3</sup> / <sub>4</sub> x3 <sup>3</sup> / <sub>4</sub> x10	426x95x254	—	—	MBA214
Glove Box Holder	10x3 <sup>3</sup> / <sub>4</sub> x5 <sup>3</sup> / <sub>4</sub>	254x95x146	2	.91	MBA215*
3 Side Bins	Each Bin: 4x4 <sup>1</sup> / <sub>2</sub> x18 <sup>5</sup> / <sub>8</sub>	102x114x254	13	5.9	MBP216
Wire Basket	13x3 <sup>1</sup> / <sub>2</sub> x10	330x89x254	1	.455	MBA218*
Waste Container — No Top (28 Quart)	15 <sup>1</sup> / <sub>4</sub> x14 <sup>3</sup> / <sub>8</sub> x10 <sup>1</sup> / <sub>4</sub>	387x365x260	3	1.37	MBA221*
Side Shelf — 25 lb. (11kg) Capacity	14 <sup>7</sup> / <sub>8</sub> L.x17 <sup>3</sup> / <sub>4</sub> W.	378L.x451W.	8	3.6	MBP230
Oxygen Tank Brackets	7L.x7W.	178L.x178W.	2	.91	MBA235*
Catheter Holder, Short 19" (482mm)	19x4x8	482x102x203	8	3.64	MBA241*
Catheter Holder, Short 19" (482mm) — Clear Front	19x4x4	482x102x102	8	3.64	MBA242*
Catheter Holder, Long 28" (711mm)	28x4x8	711x102x203	8	3.64	MBA243*
Catheter Holder, Long 28" (711mm) — Clear Front	28x4x4	711x102x102	8	3.64	MBA244*
Scope Holder, 2	48x6x9	1219x152x229	22	10.01	MBA245*
Scope Holder, 4	48x6x16	1219x152x406	34	15.47	MBA246*
Sharps Bracket (Adjustable)	5-8 <sup>1</sup> / <sub>4</sub> to 8 <sup>1</sup> / <sub>2</sub> -17	127-210 to 216-432	1	.455	MBP250*
Lockable Sharps Container	24 <sup>1</sup> / <sub>4</sub> x13x5 <sup>1</sup> / <sub>2</sub>	105x133x203	4	1.82	MBA251*
Hospital Grade Outlet Strip Outlets, 15' (4572mm) Cord	4 <sup>1</sup> / <sub>8</sub> x5 <sup>1</sup> / <sub>4</sub> x8	105x133x203	4	1.82	MBA696

\*Mount to MBP205 or MBP207.

\*\*25lbs. (12kg) weight capacity.

†Not for compact cart.



MBP230



MBA200



MBP205



MBA235,  
MBA696



MBA221



MBA218



MBP209



MBA241



MBA244



MBA245



MBA246



MBP250



MBP216



MBA215



MBA605



MBA664



MBA667



MBA696



MBP410



MBP602



MBP610

### Accessories (Cart Mounted)

Description	Dimensions		Approx. Pkd. Wt.		Cat. No.
	(in.)	(mm)	(lbs.)	(kg)	
Pass Thru Side Shelf	—	—	—	—	MBP300 <sup>†</sup>
Plastic Seals (100 per Package)	—	—	1	.455	MBA400
Breakaway Lock Bar	3	76	1	.455	MBP401
Breakaway Lock Bar	6	152	1	.455	MBP402
Breakaway Lock Bar	9	230	1	.455	MBP403
Breakaway Lock Bar	12	205	1	.455	MBP404
Breakaway Lock Bar	18	203	2	.90	MBP406
Breakaway Lock Bar	21	533	3	1.36	MBP407
Breakaway Lock Bar	24	610	3	1.36	MBP408
Breakaway Lock Bar	27	686	3	1.36	MBP409
Breakaway Lock Bar	30	762	3	1.36	MBP410
Key Lock Bar	3	76	1	.455	MBP421
Key Lock Bar	6	152	1	.455	MBP422
Cardiac Board with Brackets	15 <sup>1</sup> / <sub>2</sub> x3 <sup>3</sup> / <sub>4</sub> x21 <sup>1</sup> / <sub>2</sub>	394x20x546	4	1.82	MBP600
Cardiac Board Only	15 <sup>1</sup> / <sub>2</sub> x3 <sup>3</sup> / <sub>4</sub> x21 <sup>1</sup> / <sub>2</sub>	394x20x546	4	1.82	MBA600N
Corner Defibrillator Shelf	9 <sup>1</sup> / <sub>2</sub> x12x13	241x305x330	11	5.00	MBP602*
Suction Unit Shelf	10x7 <sup>3</sup> / <sub>4</sub> x19	254x197x482	2	.91	MBA605
Cart Top Rail	5x17 <sup>1</sup> / <sub>4</sub> x28 <sup>1</sup> / <sub>2</sub>	127x451x724	4	1.82	MBP610
Coat Rack	1x3	25x76	3	1.36	MBA664
I.V. Pole	47 <sup>1</sup> / <sub>2</sub> H.x9 <sup>1</sup> / <sub>2</sub> W.	1207x241	4	1.82	MBA667
Hospital Grade Outlet Strip 6 Outlets, 15' (4572mm) Cord			4	1.82	MBA696

\*Swivels 360 degrees, 75 lbs. (35kg) weight capacity. Adjusts from 13" (330mm) L. to 18" (457mm) L.  
<sup>†</sup>25 lb. Weight Capacity

### Overbridge & Accessories

Description	Dimensions		Approx. Pkd. Wt.		Cat. No.
	(in.)	(mm)	(lbs.)	(kg)	
Wire Basket	13x3 <sup>1</sup> / <sub>2</sub> x10	330x89x254	1	.455	MBA218*
Overbridge, 1 Shelf — Narrow	20x10x27	508x254x686	10	4.55	MBP505
Overbridge, 2 Shelf — Narrow	20x10x27	508x254x686	13	5.91	MBP506
Overbridge, 3 Hanger Rails	20x1x26	508x25x686	7	3.18	MBP511
Overbridge, 3 Hanger Rails, 1 with Hooks	21x8x26	533x203x660	7	3.18	MBP512
Overbridge, 1 Shelf — Deep	21x14 <sup>1</sup> / <sub>2</sub> x27	533x368x686	11	5.00	MBP515
Overbridge, 2 Shelf — Deep	21x14 <sup>1</sup> / <sub>2</sub> x27	533x368x686	14	6.37	MBP520
Tilt Bin 3 Units	9 <sup>1</sup> / <sub>2</sub> x7 <sup>3</sup> / <sub>4</sub> x22 <sup>1</sup> / <sub>2</sub>	241x197x571	7	3.18	MBP543††
Tilt Bin 4 Units	8 <sup>1</sup> / <sub>8</sub> x6 <sup>1</sup> / <sub>2</sub> x22 <sup>1</sup> / <sub>2</sub>	206x165x571	6	2.73	MBP544††
Tilt Bin 5 Units	6 <sup>1</sup> / <sub>2</sub> x5 <sup>1</sup> / <sub>4</sub> x22 <sup>1</sup> / <sub>2</sub>	165x133x571	4	.455	MBP545††
Tilt Bin 6 Units	4 <sup>1</sup> / <sub>2</sub> x5 <sup>1</sup> / <sub>4</sub> x22 <sup>1</sup> / <sub>2</sub>	114x133x571	3	.76	MBP546††
Hanger Rail	1x26	25x660	2	.91	MBP550
Hanger Rail with Hooks	3x26	76x660	2	.91	MBP551
Tape Dispenser/Counter Top Model	4x4x11	102x102x279	5	2.27	MBA580
Tape Dispenser with 2 Brackets for Overbridge	4x4x11	102x102x279	6	2.73	MBA583
Divided Organizer with Lid and Brackets	2 <sup>1</sup> / <sub>4</sub> x7 <sup>1</sup> / <sub>8</sub> x7 <sup>1</sup> / <sub>8</sub>	57x181x181	2	.91	MBA586

\*75 lbs. (35kg) weight capacity.  
<sup>†</sup>Shelf swivels 360 degrees.  
<sup>††</sup>Mounts to overbridge rail (ordered separately).



MBA218



MBP505, MBP546, MBP544,  
(2) MBP550



MBP560



MBP512, MBP545, MBP546



MBP602



MBA580



MBA583



MBA586

## Drawer Accessories — Basix Plus and Basix

Description	Dimensions Height/Width/Length (in.)	(mm)	Approx. Pkd. Wt. (lbs.)	(kg)	Cat. No.
3" (76mm) Flexible Drawer Divider Kit			1	.455	<b>MBA113</b>
4 Perimeter Rails, 2 Long Dividers, 6 Short Dividers					<b>MBA114</b>
Additional Short Divider (1 pc.) for MBA113 (Qty. 3)					<b>MBA115</b>
Additional Long Divider (1 pc.) for MBA113 (Qty. 2)					<b>MBA116</b>
6/9" (152/230mm) Flexible Drawer Divider Kit			1	.455	<b>MBA117</b>
4 Perimeter Rails, 2 Long Dividers, 6 Short Dividers					<b>MBA118</b>
Additional Short Divider (1 pc.) for MBA116 (Qty. 3)					<b>MBA119</b>
Additional Long Divider (1 pc.) for MBA116 (Qty. 2)					<b>MBA120</b>
Additional Divider Clips (left) for MBA117					<b>MBA121</b>
Additional Divider Clips (right) for MBA117					<b>MBA122</b>
3" (76mm) Drawer Fixed Divider Kit 2 - 22" (559mm) Rails, 6 Front-to-Back Dividers			2	.91	<b>MBA123</b>
6" (152mm) Drawer Fixed Divider Kit 2 - 22" (559mm) Rails, 6 Front-to-Back Dividers			2	.91	<b>MBA126</b>
9" (230mm) Drawer Fixed Divider Kit 2 - 22" (559mm) Rails, 6 Front-to-Back Dividers			3	1.36	<b>MBA129</b>
3" (76mm) Narrow Expandable Tray	2x3 <sup>1</sup> / <sub>4</sub> x 9-15	53x83x229-381			<b>MBA148</b>
3" (76mm) Wide Expandable Tray	2x6x 9-15	53x152x229-381			<b>MBA149</b>
3" (76mm) Tray — No Dividers	2 <sup>1</sup> / <sub>4</sub> x15 <sup>1</sup> / <sub>4</sub> x 21 <sup>1</sup> / <sub>2</sub>	57x387x546	4	1.82	<b>MBA150</b>
3" (76mm) Tray with 2 Long and 6 Short Dividers	2 <sup>1</sup> / <sub>4</sub> x15 <sup>1</sup> / <sub>4</sub> x 21 <sup>1</sup> / <sub>2</sub>	57x387x546	5	2.27	<b>MBA151</b>
3" (76mm) Tray with 2 Long 8 Short and 14 Ampule Dividers	2 <sup>1</sup> / <sub>4</sub> x15 <sup>1</sup> / <sub>4</sub> x 21 <sup>1</sup> / <sub>2</sub>	57x387x546	5	2.27	<b>MBA152</b>
3" (76mm) Tray, 2 Long, 7 Short, & 18 Ampule Dividers	2 <sup>1</sup> / <sub>4</sub> x15 <sup>1</sup> / <sub>4</sub> x 21 <sup>1</sup> / <sub>2</sub>	57x387x546	5	2.27	<b>MBA153</b>
3" (76mm) Tray, 33 Ampule Dividers with Lid	2 <sup>1</sup> / <sub>4</sub> x15 <sup>1</sup> / <sub>4</sub> x 21 <sup>1</sup> / <sub>2</sub>	57x387x546	8	3.64	<b>MBA154</b>
3" (76mm) Tray, 33 Ampule Dividers — No Lid	2 <sup>1</sup> / <sub>4</sub> x15 <sup>1</sup> / <sub>4</sub> x 21 <sup>1</sup> / <sub>2</sub>	57x387x546	6	2.73	<b>MBA155</b>
Clear Lid for MBA150 thru MBA155 and MBA159			2	.91	<b>MBA158</b>
6" (152mm) Tray with 2 Long, 6 Short Dividers	5x15 <sup>1</sup> / <sub>4</sub> x21 <sup>1</sup> / <sub>2</sub>	127x387x546	7	3.18	<b>MBA159</b>
Full Drawer Tray with Lid	2 <sup>9</sup> / <sub>4</sub> 16x22	70x406x559	4	1.82	<b>MBA160</b>
Divider Set for MBA160	2 - 20 <sup>5</sup> / <sub>8</sub> " (524mm), 4 - 14" (356mm), 6 - 5 <sup>1</sup> / <sub>2</sub> " (140mm)		2	.91	<b>MBA161</b>
3" (76mm) Drawer Tote, Maximum 2 per Drawer	2 <sup>9</sup> / <sub>4</sub> x16 <sup>1</sup> / <sub>2</sub> x10 <sup>7</sup> / <sub>8</sub>	70x419x276	1	.455	<b>MBA162</b>
Long Divider for MBA162, 11 Maximum per Tote			.38	.173	<b>MBA163</b>
Short Divider for MBA162, 7 Maximum per Tote			.3	.136	<b>MBA164</b>
5" (127mm) Drawer Tote, Maximum 2 per Drawer	6x16 <sup>1</sup> / <sub>2</sub> x10 <sup>7</sup> / <sub>8</sub>	152x419x276	2	.92	<b>MBA165</b>
Long Divider for MBA165, 11 Maximum per Tote			.75	.341	<b>MBA166</b>
Short Divider for MBA165, 7 Maximum per Tote			.5	.227	<b>MBA167</b>
Label Holders with Blanks (100 per Package)	3L.x1H.	76x25	1	.455	<b>MBA170</b>
Label Holders with Blanks (100 per Package)	7L.x2H.	178x51	2	.92	<b>MBA171</b>
Label Holders (12 per Package)	7L.x2H.	178x51	.2	.091	<b>MBA172</b>
Security Bags for 3" (76mm) Tray (20 per Package) — Fits MBA150-MBA155			1	.455	<b>MBA183</b>
Security Bags for 5" (127mm) Tray (20 per Package) — Fits MBA159			1	.455	<b>MBA185</b>
Lockable Drawer Cover			5	2.27	<b>MBA190</b>
Security Box	2 <sup>5</sup> / <sub>8</sub> x16x11	67x406x279	7	3.18	<b>MBA193</b>
Punch Card Security Box	9x16x7	229x406x167	5	2.27	<b>MBA199</b>



MBA113



MBA116



MBA123



MBA126



MBA129



MBA183



\*Long flexible dividers are available in natural color only.



MBA151



MBA152



MBA153



(2) MBA162 with Dividers



MBA171-MBA172



MBA159



Cart: MBPC3110TL  
Color: MBC-YE  
(shown with accessories)



Cart: MBPC3210TL  
Color: MBC-LT  
(shown with accessories)

### BASIX PLUS COMPACT CARTS

#### Basic Carts — 22<sup>1</sup>/<sub>2</sub>" (572mm)W x 24" (610mm)L Low Profile — 38" (965mm) High

Drawer Space	Drawer Configuration	Color	Lock	Approx. Pkd. Wt. (lbs.) (kg)	Cat. No.
24" (610mm)	3 - 3" (76mm) 1 - 6" (152mm) 1 - 9" (230mm)	Two Tone	Key Lock	133 61	<b>MBPC3110TL</b>
24" (610mm)	1 - 3" (76mm) 2 - 6" (152mm) 1 - 9" (230mm)	Two Tone	Key Lock	133 61	<b>MBPC1210TL</b>

#### High Profile — 44" (1118mm) High

Drawer Space	Drawer Configuration	Color	Lock	Approx. Pkd. Wt. (lbs.) (kg)	Cat. No.
30" (762mm)	3 - 3" (76mm) 2 - 6" (152mm) 1 - 9" (230mm)	Two Tone	Key Lock	145 66	<b>MBPC3210TL</b>

\*Note: Drawer color and solid cart body color is specified by ordering the desired color/code on page 190.

### Build-A-Cart Cart Body

#### Low Profile — 38" (965mm) High

Drawer Space	Drawer Configuration	Color	Lock	Width (in.) (mm)	Length (in.) (mm)	Cat. No.
24" (610mm)	Empty	Two Tone	Key Lock	22 <sup>1</sup> / <sub>2</sub> 572	24 610	<b>MBPC24TL</b>

#### High Profile — 44" (1118mm) High

Drawer Space	Drawer Configuration	Color	Lock	Width (in.) (mm)	Length (in.) (mm)	Cat. No.
30" (762mm)	Empty	Two Tone	Key Lock	22 <sup>1</sup> / <sub>2</sub> 572	24 610	<b>MBPC30TL</b>

### Drawers

Description	Height (lbs.) (kg)	Depth (in.) (mm)	Length (in.) (mm)	Wt. Capacity (lbs.) (kg)	Cat. No.
3" (76mm) Deep Aluminum Drawer	2 <sup>7</sup> / <sub>8</sub> 73	17 432	15 381	50 24	<b>MBPC103</b>
6" (152mm) Deep Aluminum Drawer	6 <sup>1</sup> / <sub>4</sub> 159	17 432	15 381	50 24	<b>MBPC106</b>
9" (230mm) Deep Aluminum Drawer	9 <sup>3</sup> / <sub>8</sub> 238	17 432	15 381	50 24	<b>MBPC109</b>

\*Note: Drawer color and solid cart body color is specified by ordering the desired color/code on page 190.



#### Pushbutton Lock

May be ordered with key locking carts only.  
Cat. No. **MBA435**



#### Touchpad with Proximity Reader

May be ordered with key locking carts only.  
Cat. No. **MBP445**

### Add Keyless Entry to any Basix Plus Cart

Description	Cat. No.
Mechanical Pushbutton Lock	<b>MBA435</b>
Electronic Touchpad with Auto Lock and 100 User Codes	<b>MBP440</b>
Proximity Reader/Electronic Touchpad (Compatible with Mifare 13.56MHz ISO14443A Cards)	<b>MBP445*</b>
Retro-Fit Proximity Reader (Compatible with Mifare 13.56MHz ISO14443A Cards)	<b>MBP450*</b>
Proximity Card	<b>MBA441</b>
Proximity Sticker	<b>MBA442</b>
Proximity Key Fob	<b>MBA443</b>

\*Readers may not be compatible with all cards. A sample card must be submitted to verify compatibility. Contact your Metro representative.

## Drawer Accessories — Basix Plus Compact and Basix Compact

Description	Dimensions Height/Width/Length (in.) (mm)	Approx. Pkd. Wt. (lbs.) (kg)	Cat. No.
3" (76mm) Flexible Drawer Divider Kit		1 .455	<b>MBC113</b>
4 Perimeter Rails, 2 Long, 5 Short Dividers			<b>MBA114</b>
Additional Short Divider (1 pc.) for MBC113 (Qty. 3)			<b>MBC115</b>
Additional Long Divider (1 pc.) for MBC113 (Qty. 2)			<b>MBC116</b>
6" (152mm) Flexible Drawer Divider Kit		1 .455	<b>MBC116</b>
4 Perimeter Rails, 2 Long, 5 Short Dividers			<b>MBA117</b>
Additional Short Divider (1 pc.) for MBC116 (Qty. 3)			<b>MBA118</b>
Additional Long Divider (1 pc.) for MBC116 (Qty. 2)			<b>MBC123</b>
3" (76mm) Fixed Drawer Divider Kit		1 .455	<b>MBC123</b>
2 Rails, 4 Front-to-Back Dividers			<b>MBC126</b>
6" (152mm) Fixed Drawer Divider Kit			<b>MBC126</b>
2 Rails 4 Front-to-Back Dividers			<b>MBC129</b>
9" (203mm) Fixed Drawer Divider Kit		4 1.82	<b>MBC129</b>
2 Rails, 4 Front-to-Back Dividers			<b>MBC150</b>
3" (76mm) Drawer Tray	3x14x16	76x356x406	4 1.82 <b>MBC150</b>
2 Long, 4 Short, 10 Ampule Dividers			<b>MBC151</b>
3" (76mm) Drawer Tray	3x14x16	76x356x406	4 1.82 <b>MBC151</b>
2 Long, 5 Short Dividers			



MBC113



MBC150



MBA664

## Cart Accessories — Basix Plus Compact

### Cart Mounted

Description	Dimensions Height/Width/Length (in.) (mm)	Approx. Pkd. Wt. (lbs.) (kg)	Cat. No.
Cart Top Rail	5x21x 17 <sup>3</sup> / <sub>4</sub>	127x533x451	4 1.82 <b>MBPC210</b>
Coat Rack	1x3	25x76	3 1.36 <b>MBA664</b>
I.V. Pole	47 <sup>1</sup> / <sub>2</sub> H.x9 <sup>1</sup> / <sub>2</sub> W.	1207x241	4 1.82 <b>MBA667</b>
Hospital Grade Outlet Strip 6 Outlets, 15' (4572mm) Cord			4 1.82 <b>MBA696</b>



MBA664

## Overbridge & Accessories

Description	Dimensions Height/Width/Length (in.) (mm)	Approx. Pkd. Wt. (lbs.) (kg)	Cat. No.
Overbridge, 3 Hanger Rails		7 3.18	<b>MBPC511</b>
Wire Basket	13x3 <sup>1</sup> / <sub>2</sub> x10	330x89x254	1 .455 <b>MBA218*</b>
Tape Dispenser/Counter Top Model	4x4x11	102x102x279	5 2.27 <b>MBP580</b>
Tape Dispenser with 2 Brackets for Overbridge	4x4x11	102x102x279	6 2.73 <b>MBP583</b>



MBA667

## Side Accessories — Basix Plus and Basix Plus Compact

Description	Dimensions Height/Width/Length (in.) (mm)	Approx. Pkd. Wt. (lbs.) (kg)	Cat. No.
Side Storage Unit 30"H. (762mm) with 3 Shelves	34 <sup>3</sup> / <sub>8</sub> x18x13 <sup>1</sup> / <sub>2</sub>	886x457x342	52 23.7 <b>MBA200</b>
Side Accessory Bracket (2 Pack)	4x18x <sup>1</sup> / <sub>4</sub>	102x457x6	1 .455 <b>MBP205</b>
Back Accessory Bracket (2 Pack)	4x26 <sup>1</sup> / <sub>4</sub>	102x643	2 .91 <b>MBP207†</b>
Push Handles (Pair)	—	—	1 .455 <b>MBP209</b>
3 Wide Glove Box Holder	16 <sup>3</sup> / <sub>4</sub> x3 <sup>3</sup> / <sub>4</sub> x10	426x95x254	- - <b>MBA214</b>
Glove Box Holder	10x3 <sup>3</sup> / <sub>4</sub> x5 <sup>3</sup> / <sub>4</sub>	254x95x146	2 .91 <b>MBA215*</b>
3 Side Bins	Each Bin: 4x4 <sup>1</sup> / <sub>2</sub> x18 <sup>3</sup> / <sub>8</sub>	102x114x254	13 5.9 <b>MBP216</b>
Wire Basket	13x3 <sup>1</sup> / <sub>2</sub> x10	330x89x254	1 .455 <b>MBA218*</b>
Waste Container — No Top (28 Quart)	15 <sup>1</sup> / <sub>4</sub> x14 <sup>3</sup> / <sub>8</sub> x10 <sup>1</sup> / <sub>4</sub>	387x365x260	3 1.37 <b>MBA221*</b>
Side Shelf — 25 lb. (11kg) Capacity	14 <sup>7</sup> / <sub>8</sub> L.x17 <sup>3</sup> / <sub>4</sub> W.	378L.x451W.	8 3.6 <b>MBP230</b>
Oxygen Tank Brackets	7L.x7W.	178L.x178W.	2 .91 <b>MBA235*</b>
Catheter Holder, Short 19" (482mm)	19x4x8	482x102x203	8 3.64 <b>MBA241*</b>
Catheter Holder, Short 19" (482mm) — Clear Front	19x4x4	482x102x102	8 3.64 <b>MBA242*</b>
Catheter Holder, Long 28" (711mm)	28x4x8	711x102x203	8 3.64 <b>MBA243*</b>
Catheter Holder, Long 28" (711mm) — Clear Front	28x4x4	711x102x102	8 3.64 <b>MBA244*</b>
Scope Holder, 2	48x6x9	1219x152x229	22 10.01 <b>MBA245*</b>
Scope Holder, 4	48x6x16	1219x152x406	34 15.47 <b>MBA246*</b>
Sharps Bracket (Adjustable)	5-8 <sup>1</sup> / <sub>4</sub> to 8 <sup>1</sup> / <sub>2</sub> -17	127-210 to 216-432	1 .455 <b>MBP250*</b>
Lockable Sharps Container	24 <sup>1</sup> / <sub>4</sub> x13x5 <sup>1</sup> / <sub>2</sub>	105x133x203	4 1.82 <b>MBA251*</b>
Hospital Grade Outlet Strip Outlets, 15' (4572mm) Cord	4 <sup>1</sup> / <sub>8</sub> x5 <sup>1</sup> / <sub>4</sub> x8	105x133x203	4 1.82 <b>MBA696</b>



MBA667

\*Mount to MBP205 or MBP207.

\*\*25lbs. (12kg) weight capacity.

†Not for compact cart.

# MetroBasix.

## Performance for any Application.

Convenience features include: extendible I.V. pole, overbridge storage, wire basket, side shelf, push handles and more...

Polymer drawer pulls conveniently located at the top of the drawer.

Double-wall steel body with powder-coated finish provides structural integrity.

Polymer top work surface with 1/8" (3mm) lip is standard on all Basix carts.

Choice of locking: security seals, key-lock or push-button keyless lock.

Full extension drawers (with interchangeable/removeable color drawer fronts) provide complete access to contents. Available in 3", 6", 9", 12" (76, 152, 229, 305mm).

Polymer base reduces weight of cart and provides impact protection to cart and surroundings.

5" (127mm) total lock casters on the front of the cart and directional lock casters on the rear of the cart.



A color code must be included with each cart/drawer ordered. The color code determines the color of the drawer and on solid carts the color of the cart. The quantity should equal the total number of carts.



**NEW CONTEMPORARY COLORS**



Cart packages include cart & accessories shown.



Code Response Cart  
Cat. No. **MBX4101CRT1**  
(Color Shown: MB-CB)

Accessory Package  
Cat. No. **MBXCR-1**



Code Response Cart  
Cat. No. **MBX3210CRT2**  
(Color Shown: MB-RE)

Accessory Package  
Cat. No. **MBXCR-2**



Code Response Cart  
Cat. No. **MBX3210CRT3**  
(Color Shown: MB-RE)

Accessory Package  
Cat. No. **MBXCR-3**



Anesthesia Cart  
Cat. No. **MBX3210ANES3**  
(Color Shown: MB-SB)

Accessory Package  
Cat. No. **MBXANES-1**



Anesthesia Cart  
Cat. No. **MBX1310ANES4**  
(Color Shown: MB-SB)

Accessory Package  
Cat. No. **MBXANES-2**



Isolation Cart  
Cat. No. **MBX3110ISO**  
(Color Shown: MB-YE)

Accessory Package  
Cat. No. **MBXISO-1**



Endoscopic Cart  
Cat. No. **MBX3110ENDO**  
(Color Shown: MB-MA)

Accessory Package  
Cat. No. **MBXENDO-1**



Trauma Cart  
Cat. No. **MBX3210TRAUMA**  
(Color Shown: MB-HG)

Accessory Package  
Cat. No. **MBXED-1H**



General Cart  
Cat. No. **MBX1310GEN**  
(Color Shown: MB-SB)

Accessory Package  
Cat. No. **MBXBAS-1**

## Accessory Packages

Cat. No. / Description	Corner Defib. Shelf	Backboard	I. V. Pole	Plastic Seals	O. Tank Brackets	Side Accy. Bracket	Waste Container	Suction Unit Shelf	3" (76mm) Tray with Dividers	Side Shelf	Chart Top Rail	Overbridge Shelf	Overbridge Hanger Rail	Divided Organizer	Outlet Strip	Label Holders	4 Tilt Bins	5 Tilt Bins	6 Tilt Bins	Glove Box Holder	Shaper Bracket	Coat Rack	Scope Holder (4)	Side Bins (3)	Push Handles (2)	Pushbutton Lock
<b>MBXCR-1</b> Code Response Pkg. #1	1	1	1	1	1			1	1	1					1										1	
<b>MBXCR-2</b> Code Response Pkg. #2	1		1	1							1										1					1
<b>MBXCR-3</b> Code Response Pkg. #3	1		1	1				1				1*	2			1										1
<b>MBXANES-1</b> Anesthesia Package #1			1			1	1			1	1			3**				1	1							1
<b>MBXANES-2</b> Anesthesia Package #2			1			1	1			1		1	1					1		1	1					1
<b>MBXISO-1</b> Isolation Package #1											1										1	1				
<b>MBXENDO-1</b> Endoscopic Package #1			1							1		2	2	1									1			
<b>MBXED-1H</b> Trauma Package #1			1									1	1		1		1				1	1		1	1	
<b>MBXBAS-1</b> General Package #1			1			1	1			1											1	1				

\*Swivel shelf. \*\*One with hooks

Cart: MBX3210TB  
Color: MB-RE  
(Shown with optional accessories)



**Basic Carts**  
24<sup>1</sup>/<sub>8</sub>" W. x 30" L. (613 x 762mm)

### Low Profile — 38<sup>1</sup>/<sub>2</sub>" (978mm) High

Drawer Space	Drawer Configuration	Color	Lock	Approx. Pkd. Wt. (lbs.) (kg)	Cat. No.	List Price Each
24" (610mm)	3 - 3" (76mm) 1 - 6" (152mm) 1 - 9" (230mm)	Two Tone	Breakaway Lock Bar	151 72	<b>MBX3110TB</b>	1,923.50
24" (610mm)	3 - 3" (76mm) 1 - 6" (152mm) 1 - 9" (230mm)	Two Tone	Key Lock	151 72	<b>MBX3110TL</b>	2,155.50
24" (610mm)	1 - 3" (76mm) 2 - 6" (152mm) 1 - 9" (230mm)	Two Tone	Key Lock	151 72	<b>MBX1210TL</b>	2,140.50

\*Also available in solid body color. (Cart body color matches drawer color.)

### High Profile — 45" (11440mm) High

Drawer Space	Drawer Configuration	Color	Lock	Approx. Pkd. Wt. (lbs.) (kg)	Cat. No.	List Price Each
30" (762mm)	4 - 3" (76mm) 1 - 6" (152mm) 1 - 12" (304mm)	Two Tone	Breakaway Lock Bar	159 75	<b>MBX4101TB</b>	2,250.50
30" (762mm)	3 - 3" (76mm) 2 - 6" (152mm) 1 - 9" (230mm)	Two Tone	Breakaway Lock Bar	159 75	<b>MBX3210TB</b>	2,251.50
30" (762mm)	4 - 3" (76mm) 1 - 6" (152mm) 1 - 12" (304mm)	Two Tone	Key Lock	159 75	<b>MBX4101TL</b>	2,292.50
30" (762mm)	3 - 3" (76mm) 2 - 6" (152mm) 1 - 9" (230mm)	Two Tone	Key Lock	159 75	<b>MBX3210TL</b>	2,293.50
30" (762mm)	2 - 3" (76mm) 2 - 6" (152mm) 1 - 12" (304mm)	Two Tone	Key Lock	159 75	<b>MBX2201TL</b>	2,278.00

Cart: MBX8100TB  
Color: MB-PEDS  
(Includes handles, other accessories shown are not included)



### Pediatric Code Response Cart

24<sup>1</sup>/<sub>8</sub>" W. x 30" L. (613 x 762mm)

Drawer Space	Drawer Configuration	Color	Lock	Approx. Pkd. Wt. (lbs.) (kg)	Cat. No.	List Price Each
30" (762mm)	8 - 3" (76mm) 1 - 6" (152mm)	Two Tone	Breakaway Lock Bar	133 63	<b>MBX8100TB</b>	2,226.50

Note: Drawer color MB-PEDS quantity should equal the total number of carts.

## Drawer Accessories — Basix Plus and Basix

Description	Dimensions Height/Width/Length (in.)	(mm)	Approx. Pkd. Wt. (lbs.)	(kg)	Cat. No.
3" (76mm) Flexible Drawer Divider Kit			1	.455	<b>MBA113</b>
4 Perimeter Rails, 2 Long Dividers, 6 Short Dividers					<b>MBA114</b>
Additional Short Divider (1 pc.) for MBA113 (Qty. 3)					<b>MBA115</b>
Additional Long Divider (1 pc.) for MBA113 (Qty. 2)					<b>MBA116</b>
6/9" (152/230mm) Flexible Drawer Divider Kit			1	.455	<b>MBA117</b>
4 Perimeter Rails, 2 Long Dividers, 6 Short Dividers					<b>MBA118</b>
Additional Short Divider (1 pc.) for MBA116 (Qty. 3)					<b>MBA119</b>
Additional Long Divider (1 pc.) for MBA116 (Qty. 2)					<b>MBA120</b>
Additional Divider Clips (left) for MBA117					<b>MBA121</b>
Additional Divider Clips (right) for MBA117					<b>MBA122</b>
3" (76mm) Drawer Fixed Divider Kit 2 - 22" (559mm) Rails, 6 Front-to-Back Dividers			2	.91	<b>MBA123</b>
6" (152mm) Drawer Fixed Divider Kit 2 - 22" (559mm) Rails, 6 Front-to-Back Dividers			2	.91	<b>MBA126</b>
9" (230mm) Drawer Fixed Divider Kit 2 - 22" (559mm) Rails, 6 Front-to-Back Dividers			3	1.36	<b>MBA129</b>
3" (76mm) Narrow Expandable Tray	2x3 <sup>1</sup> / <sub>4</sub> x 9-15	53x83x229-381			<b>MBA148</b>
3" (76mm) Wide Expandable Tray	2x6x 9-15	53x152x229-381			<b>MBA149</b>
3" (76mm) Tray — No Dividers	2 <sup>1</sup> / <sub>4</sub> x15 <sup>1</sup> / <sub>4</sub> x 21 <sup>1</sup> / <sub>2</sub>	57x387x546	4	1.82	<b>MBA150</b>
3" (76mm) Tray with 2 Long and 6 Short Dividers	2 <sup>1</sup> / <sub>4</sub> x15 <sup>1</sup> / <sub>4</sub> x 21 <sup>1</sup> / <sub>2</sub>	57x387x546	5	2.27	<b>MBA151</b>
3" (76mm) Tray with 2 Long 8 Short and 14 Ampule Dividers	2 <sup>1</sup> / <sub>4</sub> x15 <sup>1</sup> / <sub>4</sub> x 21 <sup>1</sup> / <sub>2</sub>	57x387x546	5	2.27	<b>MBA152</b>
3" (76mm) Tray, 2 Long, 7 Short, & 18 Ampule Dividers	2 <sup>1</sup> / <sub>4</sub> x15 <sup>1</sup> / <sub>4</sub> x 21 <sup>1</sup> / <sub>2</sub>	57x387x546	5	2.27	<b>MBA153</b>
3" (76mm) Tray, 33 Ampule Dividers with Lid	2 <sup>1</sup> / <sub>4</sub> x15 <sup>1</sup> / <sub>4</sub> x 21 <sup>1</sup> / <sub>2</sub>	57x387x546	8	3.64	<b>MBA154</b>
3" (76mm) Tray, 33 Ampule Dividers — No Lid	2 <sup>1</sup> / <sub>4</sub> x15 <sup>1</sup> / <sub>4</sub> x 21 <sup>1</sup> / <sub>2</sub>	57x387x546	6	2.73	<b>MBA155</b>
Clear Lid for MBA150 thru MBA155 and MBA159			2	.91	<b>MBA158</b>
6" (152mm) Tray with 2 Long, 6 Short Dividers	5x15 <sup>1</sup> / <sub>4</sub> x21 <sup>1</sup> / <sub>2</sub>	127x387x546	7	3.18	<b>MBA159</b>
Full Drawer Tray with Lid	2 <sup>9</sup> / <sub>4</sub> 16x22	70x406x559	4	1.82	<b>MBA160</b>
Divider Set for MBA160	2 - 20 <sup>5</sup> / <sub>8</sub> " (524mm), 4 - 14" (356mm), 6 - 5 <sup>1</sup> / <sub>2</sub> " (140mm)		2	.91	<b>MBA161</b>
3" (76mm) Drawer Tote, Maximum 2 per Drawer	2 <sup>9</sup> / <sub>4</sub> x16 <sup>1</sup> / <sub>2</sub> x10 <sup>7</sup> / <sub>8</sub>	70x419x276	1	.455	<b>MBA162</b>
Long Divider for MBA162, 11 Maximum per Tote			.38	.173	<b>MBA163</b>
Short Divider for MBA162, 7 Maximum per Tote			.3	.136	<b>MBA164</b>
5" (127mm) Drawer Tote, Maximum 2 per Drawer	6x16 <sup>1</sup> / <sub>2</sub> x10 <sup>7</sup> / <sub>8</sub>	152x419x276	2	.92	<b>MBA165</b>
Long Divider for MBA165, 11 Maximum per Tote			.75	.341	<b>MBA166</b>
Short Divider for MBA165, 7 Maximum per Tote			.5	.227	<b>MBA167</b>
Label Holders with Blanks (100 per Package)	3L.x1H.	76x25	1	.455	<b>MBA170</b>
Label Holders with Blanks (100 per Package)	7L.x2H.	178x51	2	.92	<b>MBA171</b>
Label Holders (12 per Package)	7L.x2H.	178x51	.2	.091	<b>MBA172</b>
Security Bags for 3" (76mm) Tray (20 per Package) — Fits MBA150-MBA155			1	.455	<b>MBA183</b>
Security Bags for 5" (127mm) Tray (20 per Package) — Fits MBA159			1	.455	<b>MBA185</b>
Lockable Drawer Cover			5	2.27	<b>MBA190</b>
Security Box	2 <sup>5</sup> / <sub>8</sub> x16x11	67x406x279	7	3.18	<b>MBA193</b>
Punch Card Security Box	9x16x7	229x406x167	5	2.27	<b>MBA199</b>



MBA113



MBA116



MBA123



MBA126



MBA129



MBA151



MBA152



MBA153



MBA183



(2) MBA162 with Dividers



MBA171-MBA172



MBA159



\*Long flexible dividers are available in natural color only.

**Build-A-Cart  
Cart Body**

**Low Profile — 38 1/2" (978mm) High**

Drawer Space	Drawer Configuration	Color	Lock	Width (in./mm)		Length (in./mm)		Cat. No.
24" (610mm)	Empty	Two Tone	Breakaway Lock Bar	24 1/8	613	30	762	<b>MBX24TB</b>
24" (610mm)	Empty	Two Tone	Key Lock	24 1/8	613	30	762	<b>MBX24TL</b>

**High Profile — 45" (1143mm) High**

Drawer Space	Drawer Configuration	Color	Lock	Width (in./mm)		Length (in./mm)		Cat. No.
30" (762mm)	Empty	Two Tone	Breakaway Lock Bar	24 1/8	613	30	762	<b>MBX30TB</b>
30" (762mm)	Empty	Two Tone	Key Lock	24 1/8	613	30	762	<b>MBX30TL</b>

Note: Drawer color and solid cart body color is specified by ordering the desired color/code from page 186.

**Drawers**

Description	Wt. Capacity (lbs./kg)		Depth (in./mm)		Length (in./mm)		Height (in./mm)		Cat. No.
3" (76mm) Deep Steel Drawer	50	24	17	432	22 1/4	565	2 7/8	73	<b>MBX103</b>
6" (152mm) Deep Steel Drawer	50	24	17	432	22 1/4	565	6 1/4	159	<b>MBX106</b>
9" (230mm) Deep Steel Drawer	50	24	17	432	22 1/4	565	9 3/8	238	<b>MBX109</b>
12" (305mm) Deep Steel Drawer	50	24	17	432	22 1/4	565	12 1/4	311	<b>MBX112</b>

**Side Accessories**

Description	Dimensions Height/Width/Length (in./mm)		Approx. Pkd. Wt. (lbs./kg)		Cat. No.
Side Storage Unit 30" (762mm) H. with 3 Shelves	34 3/8x18x13 1/2		52 23.7		<b>MBA200</b>
Side Accessory Bracket	18W.x1		1 .455		<b>MBX205*</b>
Side Handle, Tubular	18W.		2 .91		<b>MBX207</b>
Utility Hooks (2 per Package)	2 1/4x1x1 1/2		1 .455		<b>MBX208</b>
Pair Push Handles			1 .455		<b>MBX209</b>
Glove Box Holder	10x3 3/4x5 3/4		2 .91		<b>MBA215</b>
3 Side Bins 24" (610mm) H each Bin	4x4 1/2x18 3/8		12 5.46		<b>MBX216*</b>
3 Side Bins 30" (762mm) H each Bin	4x4 1/2x18 3/8		12 5.46		<b>MBX217*</b>
Wire Basket	13x3 1/2x10		1 .455		<b>MBA218*</b>
Waste Container — No Top (28 Quart)	15 1/4x14 3/8x10 1/4		3 1.37		<b>MBA221*</b>
Side Shelf	14 7/8L.x17 3/4W.		8 3.64		<b>MBX230**</b>
Oxygen Tank Brackets	7L.x7W.		2 .91		<b>MBA235</b>
Catheter Holder, Short 19" (482mm) W.	19x4x8		8 3.64		<b>MBA241</b>
Catheter Holder, Short 19" (482mm) W. — Clear Front	19x4x4		8 3.64		<b>MBA242</b>
Catheter Holder, Long 28" (711mm)	28x4x4		8 3.64		<b>MBA243</b>
Catheter Holder, Long 28" (711mm) — Clear Front	28x4x4		8 3.64		<b>MBA244</b>
Scope Holder, 2	48x6x16		22 10.01		<b>MBA245</b>
Scope Holder, 4	48x6x16		34 15.47		<b>MBA246</b>
Sharps Bracket			2 .91		<b>MBX250</b>
Hospital Grade Outlet Strip — 6 Outlets, 15' (4572mm) Cord			4 1.82		<b>MBA696</b>

\*MBX205 required for side attachment of wire basket and waste baskets.

\*\*25lbs. (12kg) weight capacity.



MBA200



MBA235



MBX207



MBX208



MBX209



MBA215, MBX250



MBA221

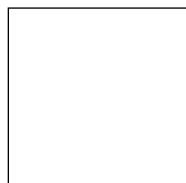

MBX230



MBA241



MBA244



MBA245



MBA246



Pushbutton Lock



MBX600



MBA605



MBX602



MBX610

**Drawer Accessories — Basix Plus Compact and Basix Compact**

Description	Dimensions Height/Width/Length (in.)	Approx. Pkd. Wt. (lbs.) (kg)	Cat. No.
3" (76mm) Flexible Drawer Divider Kit (4 Perimeter Rails, 2 Long, 5 Short Dividers )		1 .455	<b>MBC113</b>
Additional Short Divider (1 pc.) for MBC113 (Qty. 3)			<b>MBA114</b>
Additional Long Divider (1 pc.) for MBC113 (Qty. 2)			<b>MBC115</b>
6" (152mm) Flexible Drawer Divider Kit (4 Perimeter Rails, 2 Long, 5 Short Dividers)		1 .455	<b>MBC116</b>
Additional Short Divider (1 pc.) for MBC116 (Qty. 3)			<b>MBA117</b>
Additional Long Divider (1 pc.) for MBC116 (Qty. 2)			<b>MBA118</b>
3" (76mm) Fixed Drawer Divider Kit (2 Rails, 4 Front-to-Back Dividers)		1 .455	<b>MBC123</b>
6" (152mm) Fixed Drawer Divider Kit (2 Rails 4 Front-to-Back Dividers)			<b>MBC126</b>
9" (203mm) Fixed Drawer Divider Kit (2 Rails, 4 Front-to-Back Dividers)		4 1.82	<b>MBC129</b>
3" (76mm) Drawer Tray 2 Long, 4 Short, 10 Ampule Dividers	3x14x16 76x356x406	4 1.82	<b>MBC150</b>
3" (76mm) Drawer Tray (2 Long, 5 Short Dividers)	3x14x16 76x356x406	4 1.82	<b>MBC151</b>

**Accessories (Cart Mounted)**

Description	Dimensions Height/Width/Length (in.)	Dimensions Height/Width/Length (mm)	Approx. Pkd. Wt. (lbs.) (kg)	Cat. No.
Plastic Seals (100 per Package)			1 .455	<b>MBA400</b>
Mechanical Push Button Lock			1 .455	<b>MBA435</b>
Cardiac Board with Brackets	15 1/2 H.x21 1/2 L.x3/4 W.	394H.x546L.x20W	4 1.82	<b>MBX600</b>
Cardiac Board Only			4 1.82	<b>MBX600N</b>
Corner Defibrillator Shelf			11 5.00	<b>MBX602</b>
Suction Unit Shelf	10H.x19L.x73/4W.	254x482x197	2 .91	<b>MBA605</b>
Cart Top Rail	5x17 3/4x28 1/2	127x451x724	4 1.82	<b>MBX610</b>
Coat Rack			3 1.36	<b>MBA664</b>
I.V. Pole			4 1.82	<b>MBA667</b>
Hospital Grade Outlet Strip — 6 Outlets, 15' (4572mm) Cord			4 1.82	<b>MBA696</b>

\*Swivels 360 degrees, 75 lbs. (35kg) weight capacity.



MBA235, MBA667, MBA696

**Overbridge & Accessories**

Description	Dimensions Height/Width/Length (in.)	Dimensions Height/Width/Length (mm)	Approx. Pkd. Wt. (lbs.) (kg)	Cat. No.
Overbridge, 3 Hanger Rails	22H.x27L.	559x686	6 2.73	<b>MBX511</b>
Overbridge, 3 Hanger Rails, 1 with Hook	22H.x27L.	559x686	6 2.73	<b>MBX512</b>
Overbridge with 1 Shelf, 1 Hanger Rail	14W.x27L.	356x686	10 4.55	<b>MBX515*</b>
Overbridge with 2 Shelves, 2 Hanger Rails	14W.x27L.	356x686	20 9.1	<b>MBX520*</b>
Tilt Bin 3 Units with Brackets	9 1/2x7 3/4x22 1/2	241x197x571	7 3.18	<b>MBX543††</b>
Tilt Bin 4 Units with Brackets	8 1/8x6 1/2x22 1/2	206x165x571	6 2.73	<b>MBX544††</b>
Tilt Bin 5 Units with Brackets	6 1/2x5 1/4x22 1/2	165x133x571	4 1.82	<b>MBX545††</b>
Tilt Bin 6 Units with Brackets	4 1/2x5 1/4x22 1/2	114x133x571	3 1.37	<b>MBX546††</b>
Tape Dispenser/Counter Top Model			5 2.28	<b>MBA580</b>
Tape Dispenser with 2 Brackets for Overbridge	4x4x11	102x102x279	6 2.73	<b>MBA583</b>
Divided Organizer with Lid and Brackets	2 1/4x7 1/8x7 1/8	57x181x181	2 .91	<b>MBA586</b>
Overbridge with 1 Swivel Shelf, 2 Hanger Rails	14W.x27L.	356x686	26 11.83	<b>MBX615*†</b>
Overbridge with 2 Shelves (Top Swivel), 1 Hanger Rail	14W.x27L.	356x686	30 13.65	<b>MBX620*†</b>

\*75 lbs. (35kg) weight capacity

†Shelf swivels 360 degrees.

††Mounts to overbridge rail (ordered separately).



MBX511, MBX545, MBX546



MBX515, MBX545



MBA583



MBA586



MBX615



MBX520

**Compact Carts**  
 18<sup>1</sup>/<sub>2</sub>" D. x 19<sup>1</sup>/<sub>4</sub>" L. x 34<sup>1</sup>/<sub>2</sub>" H. (470x489x876mm)



Cart: MBC3110TL  
 Color: MBC-LA (Lavender)  
 Two Tone

Drawer Space	Drawer Configuration	Color	Lock	Approx. Pkd. Wt. (lbs.) (kg)	Cat. No.*
24" (610mm)	3 - 3" (76mm) 1 - 6" (152mm) 1 - 9" (230mm)	Two Tone	Key Lock	133 63	<b>MBC3110TL*</b>
24" (610mm)	1 - 3" (76mm) 2 - 6" (152mm) 1 - 9" (230mm)	Two Tone	Key Lock	133 63	<b>MBC1210TL*</b>

\*Note: Drawer color and solid cart body color is specified by ordering the desired color/code.

\*Available in solid body color.

**Build-A-Cart**  
**Cart Body** — 34<sup>1</sup>/<sub>2</sub>" H. (876mm)

Drawer Space	Drawer Configuration	Color	Lock	Width (in.) (mm)	Length (in.) (mm)	Cat. No.*
24" (610mm)	Empty	Two Tone	Key Lock	18 <sup>1</sup> / <sub>2</sub> 470	19 <sup>1</sup> / <sub>4</sub> 489	<b>MBC24TL*</b>

\*Note: Drawer color and solid cart body color is specified by ordering the desired color/code.

**Drawers**

Description	Wt. Capacity† (lbs.) (kg)	Depth (in.) (mm)	Length (in.) (mm)	Height (in.) (mm)	Cat. No.*
3" (76mm) Deep Steel Drawer	15 7	17 432	15 381	2 <sup>7</sup> / <sub>8</sub> 73	<b>MBC103</b>
6" (152mm) Deep Steel Drawer	15 7	17 432	15 381	6 <sup>1</sup> / <sub>4</sub> 159	<b>MBC106</b>
9" (230mm) Deep Steel Drawer	15 7	17 432	15 381	9 <sup>7</sup> / <sub>8</sub> 238	<b>MBC109</b>

†Drawer capacity is determined by cart stability when drawers are fully extended.

\*Note: Drawer color and solid cart body color is specified by ordering the desired color/code.



Cart: MBC1210TL  
 Color: MBC-DT (Dark Taupe)  
 Two Tone



MBX208



MBA586



MBA215, MBX250



MBA221



**Pushbutton Lock**  
 May be ordered with key locking carts only.  
 Cat. No. **MBA435**

A color code must be included with each cart/drawer ordered. The color code determines the color of the drawer and on solid carts the color of the cart. The quantity should equal the total number of carts.



Cat. No. <b>MBC-BG</b> Blue Gray	Cat. No. <b>MBC-CB</b> Crash Cart Blue	Cat. No. <b>MBC-CR</b> Cranberry	Cat. No. <b>MBC-DB</b> Dark Blue	Cat. No. <b>MBC-DT</b> Dark Taupe	Cat. No. <b>MBC-HG</b> Hunter Green	Cat. No. <b>MBC-LA</b> Lavender	Cat. No. <b>MBC-LT</b> Light Taupe	Cat. No. <b>MBC-MA</b> Mauve	Cat. No. <b>MBC-RE</b> Red	Cat. No. <b>MBC-SB</b> Slate Blue	Cat. No. <b>MBC-SG</b> Sea Foam Green	Cat. No. <b>MBC-TE</b> Teal	Cat. No. <b>MBC-YE</b> Yellow
-------------------------------------	---	-------------------------------------	-------------------------------------	--------------------------------------	--	------------------------------------	---------------------------------------	---------------------------------	-------------------------------	--------------------------------------	--	--------------------------------	----------------------------------

**NEW CONTEMPORARY COLORS**





MBC207



MBX208



MBX230



MBA215, MBX250



MBA221

## Cart Accessories

Description	Dimensions		Approx. Pkd. Wt.		Cat. No.
	(in.)	Height/Width/Length (mm)	(lbs.)	(kg)	
Accessory Bar Bracket	18H.	457H.	1	.455	<b>MBX205*</b>
Side Handle, Tubular	18H.	457H.	2	.91	<b>MBC207</b>
Utility Hooks (2 per Package)	2 <sup>1</sup> / <sub>4</sub> x1x <sup>1</sup> / <sub>2</sub>	57x25x13	1	.455	<b>MBX208</b>
Compact Cart Rail			4	1.82	<b>MBC210</b>
Glove Box Holder	10x3 <sup>3</sup> / <sub>4</sub> x5 <sup>3</sup> / <sub>4</sub>	254x95x146	2	.91	<b>MBA215</b>
Wire Basket	13x10x3 <sup>1</sup> / <sub>2</sub>		1	.455	<b>MBA218*</b>
Waste Container — No Top (28 Quart)	15 <sup>1</sup> / <sub>4</sub> x14 <sup>3</sup> / <sub>8</sub> x10 <sup>1</sup> / <sub>4</sub>	387x365x260	3	1.37	<b>MBA221*</b>
Side Shelf	14 <sup>7</sup> / <sub>8</sub> L.x17 <sup>3</sup> / <sub>4</sub> W.	378L.x451W.	8	3.64	<b>MBX230**</b>
Catheter Holder, Short 19" (482mm)	19x4x8	482x102x203	8	3.64	<b>MBA241</b>
Catheter Holder, Short 19" (482mm) — Clear Front	19x4x4	482x102x102	8	3.64	<b>MBA242</b>
Catheter Holder, Long 28" (711mm)	28x4x8	711x102x203	8	3.64	<b>MBA243</b>
Catheter Holder, Long 28" (711mm) — Clear Front	28x4x4	711x102x102	8	3.64	<b>MBA244</b>
Sharps Bracket			2	.91	<b>MBX250</b>
I.V. Pole			4	1.82	<b>MBA667</b>

\*MBX205 required for side attachment of wire basket and waste baskets.  
 \*\*25lbs. (12kg) weight capacity.



MBA218



MBA245

## Overbridge & Accessories

Description	Dimensions		Approx. Pkd. Wt.		Cat. No.
	(in.)	Height/Width/Length (mm)	(lbs.)	(kg)	
Trellis, 3 Tier (For Mini Cart)	18x22	457x559	6	2.73	<b>MBC511</b>
Trellis, 3 Tier with Hook for Mini Cart	18x22	457x559	6	2.73	<b>MBC512</b>
Tilt Bin 3 Units	9 <sup>1</sup> / <sub>2</sub> x7 <sup>3</sup> / <sub>4</sub> x22 <sup>1</sup> / <sub>2</sub>	241x197x571	7	3.18	<b>MBP543††</b>
Tilt Bin 4 Units	8 <sup>1</sup> / <sub>8</sub> x6 <sup>1</sup> / <sub>2</sub> x22 <sup>1</sup> / <sub>2</sub>	206x165x571	6	2.73	<b>MBP544††</b>
Tilt Bin 5 Units	6 <sup>1</sup> / <sub>2</sub> x5 <sup>1</sup> / <sub>4</sub> x22 <sup>1</sup> / <sub>2</sub>	165x133x571	4	.455	<b>MBP545††</b>
Tilt Bin 6 Units	4 <sup>1</sup> / <sub>2</sub> x5 <sup>1</sup> / <sub>4</sub> x22 <sup>1</sup> / <sub>2</sub>	114x133x571	3	.76	<b>MBP546††</b>
Tape Dispenser with 2 Brackets for Trellis	4x4x11	102x102x279	6	2.73	<b>MBA583</b>
Divided Organizer with Lid and Brackets	2 <sup>1</sup> / <sub>4</sub> x7 <sup>1</sup> / <sub>8</sub> x7 <sup>1</sup> / <sub>8</sub>	57x181x181	2	.91	<b>MBA586</b>

††Mounts to overbridge rail (ordered separately).



MBA244



MBX545, MBX546



MBA583



MBC511, MBX544



MBA586



MBA667



Case Carts — 33.10

The functional design of Metro Case Carts maximize usable inside space for handling storage and transport tasks efficiently. Carts can be used wherever contents must be protected from an “unclean” environment, including free-standing ambulatory care centers, surgicenters, and hospital based or out-patient surgeries.

- **Quiet:** Embossed sides and back, reinforced top and floor, softer wheels and other noise dampeners, provide a noticeably quieter ride.
- **Efficient:** Stainless steel cabinet and optional shelves have smooth or protected edges to eliminate ripping of packs that can cause costly waste or reprocessing.
- **Proficient:** Carts are designed to maximize interior cubic storage space and minimize the exterior footprint delivering the most cubic storage capacity per square foot to provide ample capacity for transport and efficiency for staging.

CASE24-H6S-P  
High-profile cart saves floor space and minimizes bending. Medium capacity, small footprint.

CASE36-H6S-P  
Cart for large or multiple cases, commonly used for orthopedics. High capacity, moderate footprint.



CASE24-L6S-P  
Cart is space efficient and can be used for minor surgery, labor and delivery and outpatient procedures. Low capacity with functional work surface.

CASE36-L6S-P  
Cart for the majority of applications. Medium capacity with functional work surface.

CASE48-L6S-P  
Cart for large cases commonly used for orthopedics. High capacity with functional work surface.



Retrofit Passive Lock Security Latch  
Cat. No. **CASE-SECLATCH**

	Width			Height			Approx. Pkd. Wt.		Cat. No. with Passive Lock	
	Overall (in.)	Cabinet (in.)	Cabinet (mm)	Overall (in.)	Cabinet (in.)	Cabinet (mm)	(lbs.)	(kg)		
33	838	27 <sup>5</sup> / <sub>8</sub>	702	39 <sup>9</sup> / <sub>16</sub>	1005	31 <sup>1</sup> / <sub>4</sub>	794	115	52	<b>CASE24-L6S-P</b>
45	1143	39 <sup>5</sup> / <sub>8</sub>	1007	39 <sup>9</sup> / <sub>16</sub>	1005	31 <sup>1</sup> / <sub>4</sub>	794	186	84	<b>CASE36-L6S-P</b>
57	1448	51 <sup>5</sup> / <sub>8</sub>	1311	39 <sup>9</sup> / <sub>16</sub>	1005	31 <sup>1</sup> / <sub>4</sub>	794	212	96	<b>CASE48-L6S-P</b>
33	838	27 <sup>5</sup> / <sub>8</sub>	702	56 <sup>15</sup> / <sub>16</sub>	1446	41 <sup>7</sup> / <sub>8</sub>	1064	162	73	<b>CASE24-H6S-P</b>
45	1143	39 <sup>5</sup> / <sub>8</sub>	1007	56 <sup>15</sup> / <sub>16</sub>	1446	41 <sup>7</sup> / <sub>8</sub>	1064	262	119	<b>CASE36-H6S-P</b>

All units are 28<sup>1</sup>/<sub>16</sub>" (729mm) deep overall. Cabinet depth is 25<sup>7</sup>/<sub>8</sub>" (657mm). Add -P suffix to end of catalog number to include security latch (i.e. CASE24-L6S-P).

Shelves

For Use with Cart Model No. Prefix	Shelf (Depth x Width) (in.) (mm)	Approx. Pkd. Wt. (lbs.) (kg)	Cat. No. Wire Shelf	Approx. Pkd. Wt. (lbs.) (kg)	Cat. No. Roller Shelf	Approx. Pkd. Wt. (lbs.) (kg)	Cat. No. Solid Shelf
CASE24-	24x24 610x610	9 4.1	<b>CASE-24WS</b>	12 5.5	<b>CASE-24RS</b>	15 6.8	<b>CASE-24SS</b>
CASE36-	24x36 610x914	13 5.9	<b>CASE-36WS</b>	16 7.3	<b>CASE-36RS</b>	19 8.6	<b>CASE-36SS</b>
CASE48-	24x48 610x1219	19 8.6	<b>CASE-48WS</b>	21 9.5	<b>CASE-48RS</b>	25 11.3	<b>CASE-48SS</b>

Each shelf includes two attachment brackets. Shelf weight capacity is 150 lbs. (68kg) evenly distributed.



Optional wire roller shelf, pulls out halfway, easily and quietly, even at the bottom level where accessibility is vital. Also available in solid or wire pullout without roller.



Ergonomically designed, full length handles (on both sides of the low profile carts) allow for convenience in pushing or pulling from either end and provide better cart control.



Detachable brackets, which hold shelves, remove for faster and easier cleaning and drying. Brackets attach and detach quickly from “keyhole” slots for easy shelf adjustability at 2" (51mm) increments.



Double panel door for optimum strength. Recessed latch eliminates a catch point. Two door models have a center flange to stop splashes from entering cart.



All stainless steel construction. Grease sealed stainless steel ball-bearings with zerk fittings. Available in 6" (152 mm) diameter, swivel, brake-lock and swivel-lock tracking options. Rounded wheel tread provides less surface contact, improving rollability. Softer tread absorbs more energy while rolling — reducing overall cart noise.

## Open Case Carts

Stainless steel provides excellent corrosion resistance and its tendency to conduct heat accelerates the drying process. Super Adjustable shelves allow you to configure a cart to your specific needs and easily reposition them as needs change.

## Preconfigured Carts

As shown on this page include (handle) posts,\* casters, and shelves. Other accessories shown are optional and ordered separately.

Shelf Width x Length (in. mm)		Overall Height (in. mm)	Post Style Handle	Cat. No.
24x36	610x910	39 991	Handle	<b>CASE-OL36H</b>
24x24	610x610	60 1524	Swaged	<b>CASE-OH24</b>
24x36	610x910	39 991	Swaged	<b>CASE-OL36</b>

\*Posts have cap swaged in to keep in place during cart wash.

## Build-A-Cart

### 1 Choose Shelf

Dimensions (in. mm)		Top/Intermediate Wire Shelves Cat. No.	All Stainless* Bottom Solid Shelf Cat. No.
24x24	610x610	<b>A2424NS</b>	<b>2424NFS</b>
24x30	610x760	<b>A2430NS</b>	<b>2430NFS</b>
24x36	610x914	<b>A2436NS</b>	<b>2436NFS</b>
24x42	610x1066	<b>A2442NS</b>	<b>2442NFS</b>
24x48	610x1219	<b>A2448NS</b>	<b>2448NFS</b>

\*All-stainless design, including stainless cast corners, can be used in cart wash applications.

### 2 Choose Four Stainless Steel Posts with Swaged\* Aluminum Post Caps or Two One-Piece Stainless Steel Handle Posts

Description	Dimensions (in. mm)		Cat. No.
Handle Post	24x34 <sup>1/2</sup>	610x880	<b>H5S</b>
Stem Caster Post	33	875	<b>33UPS-SW</b>
Stem Caster Post	54	1370	<b>54UPS-SW</b>
Stem Caster Post	63	1600	<b>63UPS-SW</b>

\*Posts have cap swaged in to keep in place during cart wash.

### 3 Choose Four Stem Casters

Stainless steel cart washable casters with polyurethane tread.

Description	Wheel Diameter (in. mm)		Cat. No.
Swivel	5	127	<b>5MPGSA</b>
Swivel/Brake	5	127	<b>5MPBGSA</b>

### 4 Choose 4" High (102mm) Stainless Steel Stackable Ledges

Description	Dimensions (in. mm)		For Wire Shelf Cat. No.	For Solid Shelf Cat. No.
Ledge for 24" (610mm) Shelf	24	610	<b>L24N-4S</b>	<b>L24WS</b>
Ledge for 30" (760mm) Shelf	30	760	<b>L30N-4S</b>	<b>L30WS</b>
Ledge for 36" (914mm) Shelf	36	914	<b>L36N-4S</b>	<b>L36WS</b>
Ledge for 42" (1066mm) Shelf	42	1066	<b>L42N-4S</b>	<b>L42WS</b>
Ledge for 48" (1219mm) Shelf	48	1219	<b>L48N-4S</b>	<b>L48WS</b>

\*Stainless Steel enclosure panels are also available. See page 56.

### 5 Optional Stainless Steel Accessories

Description	Dimensions (in. mm)		Cat. No.
8" (203mm) high Wire Shelf Divider	24x8	610x203	<b>DD24S</b>
8" (203mm) high Solid Shelf Divider	24x9	610x204	<b>DD24FS</b>
24" (610mm) deep Cart Handle	24	610	<b>EH24NS</b>



CASE-OH24  
(Shown with optional ledges)



CASE-OL36  
(Shown with optional ledges)



CASE-OL36H  
(Shown with optional ledges)



General Supply and O.R. Support Carts (See pages 215-218)



Suture Storage (See page 170)



Stent and Graft Storage (See page 170)



Instrument Storage (See page 170)



Catheter Storage (See page 171)



Scope Storage (See page 172)

Starsys™ Secure I.V. Cart — 45.10

The Starsys Secure I.V. Cart is a system of polymer components that offers security in a flexible storage/transport solution.

- Easily Accessible: Full extension shelves allow for I.V. solution bags to be stored standing upright or lying down while providing complete access to the entire product.
- JCAHO Compliant: The locking feature is in compliance with JCAHO's medication storage standards.
- Corrosion Resistant: Corrosion-proof polymer components ensure a contamination-free environment.
- Durable: Easy-to-clean polymer enclosures won't chip, rust, or dent.
- Easily Maneuverable: The lighter polymer design and 5" (127mm) casters, two with brakes, allow for easier movement and transfer of product.



SXSIVSTOR

Description	Height/Width/Length		Total Totes Per Cart	Cat. No.
	(in.)	(mm)		
Single-Wide	58x27 <sup>7</sup> / <sub>8</sub> x22 <sup>1</sup> / <sub>16</sub>	1473x708x576	3	SXSIVSTOR
Double-Wide	58x27 <sup>7</sup> / <sub>8</sub> x42 <sup>1</sup> / <sub>2</sub>	1473x708x1080	6	SXRDIVSTOR

Units feature four 5" (127mm) casters — the front two casters have color-matched toe-brakes. The dimensions of the tote boxes (MTB93080W) that are included are 8x17<sup>1</sup>/<sub>2</sub>x22<sup>1</sup>/<sub>2</sub> inches (203x445x572mm).

Accessories

Description	For Tote Box	Cat. No.
Short Dividers	MTB93080W	MDS93080NAT
Long Dividers	MTB93080W	MDL93080NAT

Description	(in.)	(mm)	Cat. No.
Snap-On Card Holder	4 <sup>1</sup> / <sub>2</sub> x8	114x199	OP2501CLR

MetroMax® I.V. Transport/Storage System — 30.20

The perfect solution for: Exchange System, Par Level Storage, Bulk Storage in Central Supply, Pharmacy Admixture, I.C.U. and E.R. Storage. Baskets have semi-open front for easy access. Dividers adjust horizontally within the basket to accept various sizes of I.V. bags. Continuous label holders identify basket contents.



MXIV1 (includes accessories as shown)

Description	Height/Width/Length		Total Baskets Per Cart	Casters	Cat. No.
	(in.)	(mm)			
Open Cart	60x24x24	1524x610x610	4	*	MXIV1
Open Cart with Top Shelf	69x24x24	1753x610x610	4	*	MXIV2
Open Cart	60x24x42	1524x610x1066	8	†	MXIV4
Open Cart with Top Shelf	69x24x42	1753x610x1066	8	†	MXIV5
Open Cart	60x24x60	1524x610x1524	12	†	MXIV6
Open Cart with Top Shelf	69x24x60	1753x610x1524	12	†	MXIV7

\*Four 5" (127mm) poly casters; two swivel, two with brakes.  
†5" (127mm) poly casters on dolly frame; two swivel, one swivel with brake, and one rigid.

Accessories

Description	(in.)	(mm)	Cat. No.
Basket with Label Holder	18 <sup>1</sup> / <sub>2</sub> x24 <sup>1</sup> / <sub>2</sub> x10	470x622x254	IVB1
Divider	9	229	IVBD



IVB1 (shown with optional Divider)



ITC12C

Inhalation Therapy Cart — 30.40

Holds size "D" and "E" cylinders.

Height/Width/Length		Approx. Pkd. Wt.		Cat. No.
(in.)	(mm)	(lbs.)	(kg)	
39x20 <sup>1</sup> / <sub>2</sub> x26	990x520x660	40 <sup>1</sup> / <sub>2</sub>	18	ITC12C



DC56EC

Suture Carts — 30.50

Slanted shelves present contents for instant identification and access. Allows logical organization, eliminates confusion, makes ordering easy.

Width/Length (in.) (mm)		Height (in.) (mm)		Description	Approx. Pkd. Wt. (lbs.) (kg)		Cat. No.
18x24	457x610	60	1524		One Flat and Four Slanted Shelves	105	
18x24	457x610	60	1524	Five Slanted Shelves	113	51	<b>DC16EC</b>
18x36	457x914	60	1524	One Flat and Four Slanted Shelves	98	44	<b>DC35EC</b>
18x36	457x914	70	1778	Five Slanted Shelves	100	45	<b>DC36EC</b>
18x48	457x1219	60	1524	One Flat and Four Slanted Shelves	115	52	<b>DC55EC</b>
18x48	457x1219	70	1778	Five Slanted Shelves	118	53.5	<b>DC56EC</b>

**Note:** All Suture Carts include package of 12 retainers.  
**Note:** Shelves slant at a 45° angle or 9" (229mm) from front to back.

Additional Wire Shelves

Width/Length (in.) (mm)	Approx. Pkd. Wt. (lbs.) (kg)	Cat. No.
18x24 457x610	10.5 4.7	<b>1824DNC</b>
18x36 457x914	14.5 6.5	<b>1836DNC</b>
18x48 457x1219	18.5 8.3	<b>1848DNC</b>



DC16EC

Additional Retainers

Length (in.) (mm)	Height (in.) (mm)	Approx. Pkd. Wt. Per 12 Pieces (lbs.) (kg)	Cat. No.
17 432	4 102	1 .25	<b>DCR17C</b>

High-Profile Sterile Wrap Rack — 33.22

Designed to provide a safe, convenient area to hold wrap. One sheet or several sheets can be removed quickly and neatly. Bottom shelf may be used to hold extra wrap or less frequently used sizes.

Shelf Width (in.) (mm)	Shelf Length (in.) (mm)	Overall Height (in.) (mm)	Bottom Shelf Material	Frame Material	Post Material	Approx. Pkd. Wt. (lbs.) (kg)	Cat. No.
24 610	48 1219	68 1727	Chrome	Chrome	Chrome	83.1 37.7	<b>SWR556DC</b>
24 610	60 1524	68 1727	Chrome	Chrome	Chrome	94.3 42.8	<b>SWR56DC</b>

**Note:** Special length posts are available. Contact your Metro representative.



SWR56DC

Additional Support Bars  
(For High-Profile Rack)

Length (in.) (mm)	Cat. No.
48 1219	<b>SWRB5S</b>
60 1524	<b>SWRB6S</b>

Accessories  
(For High-Profile Rack)

Covers are available in white and mariner blue (add "MB" suffix to Catalog No.) in both coated and uncoated styles.

Width (in.) (mm)	Length (in.) (mm)	Height (in.) (mm)	Cat. No. Uncoated	Cat. No. Coated
24 610	48 1219	62 1575	<b>24X48X62UC</b>	<b>24X48X62C</b>
24 610	60 1524	62 1575	<b>24X60X62UC</b>	<b>24X60X62C</b>

Catheter Procedure Carts — 30.47

Holds all styles and sizes of catheter packages — on hooks, shelves, in tote boxes or bins. Different size catheter hooks are easily secured onto bars, and can be adjusted to accommodate peel pouches.

Width/Length (in.) (mm)	Style	Hooks		Tote Boxes	Super Slides	Bins	Ledges	Cat. No.
		Total No. Included	Max. No. per Bar					
24x60 610x1524	Combination 3 Side Shelves — 24" (610mm); 4 Bars — 36" (914mm)	24	9	—	—	—	—	<b>CPC3/2LC</b>
24x60 610x1524	Combination 3 Side Shelves — 24" (610mm); 4 Bars — 36" (914mm)	24	9	Two 6" (152mm)	One-SS2NC	Six-MB30164Y	Four-L24N-4C Two- L60N-4C	<b>CPCD3/2LC</b>
24x48 610x1219	Bulk 4 Bars — 48" (1219mm)	32	13	—	—	Six-MB30164Y	Four-L24N-4C Two-L48N-4C	<b>CPC55EC</b>
24x60 610x1524	Bulk 4 Bars — 60" (1524mm)	40	17	—	—	Six-MB30164Y	Four-L24N-4C Two-L60N-4C	<b>CPC56EC</b>

Note: Bin markers included as pictured.

Accessories

Description	Model
Catheter Hooks and Label Holder	<b>CH4*</b>
Label Holders (Bag of 20)	<b>CH4LH</b>
36" (914mm) Catheter Bar	<b>SWRB3S</b>
48" (1219mm) Catheter Bar	<b>SWRB5S</b>
60" (1524mm) Catheter Bar	<b>SWRB6S</b>
Catheter Side Bar	<b>SB24C</b>
Tote Box (6"D.x17½"W.x22⅜"L.) (152x445x568mm)	<b>MTB93060W**</b>
Super Slide (Holds two MTB93060W)	<b>SS2NC</b>
Metro Bin (23⅝"W.x4⅛"W.x4"H.) (610x105x102mm)	<b>MB30124Y†</b>
Metro Bin (23⅝"W.x6⅝"W.x4"H.) (610x168x102mm)	<b>MB30164Y††</b>
Ledge (24"L.x4"H.) (610x102mm)	<b>L24N-4C</b>
Ledge (36"L.x4"H.) (914x102mm)	<b>L36N-4C</b>
Ledge (48"L.x4"H.) (1219x102mm)	<b>L48N-4C</b>
Ledge (60"L.x4"H.) (1524x102mm)	<b>L60N-4C</b>
Bin Marker (Attaches to Shelf)	<b>9990P</b>
Snap-On Card Holder for Tote Boxes	<b>OP2501CLR</b>

\*Order in multiples of four. Hooks are 8" (203mm) in length.

\*\*Other tote box styles available in 3", 6" and 8" (76, 152 and 203mm) depths.

†Sold in carton quantity of 12.

††Sold in carton quantity of 6.

For additional Metro Bins and Tote Boxes see pages 62 and 227.



CPC55EC



CPCD3/2LC



Close-up of Catheter Hook on Bar Assembly



Close-up of Catheter Side Bar



**PT1C-5MP**  
(Shown with totes and 4 additional pairs of slides, not included)

**Tote Box Carriers — 16.60**

Provide efficient handling of totes, trays, or other miscellaneous material handling containers

Width/Length		Height		Caster	Approx. Pkd. Wt.		Cat. No.
(in.)	(mm)	(in.)	(mm)		(lbs.)	(kg)	
<b>Single Bay</b>							
26x22 <sup>5</sup> / <sub>8</sub>	660x574	68	1727	Resilient	56	25.2	<b>PT1C-5M*</b>
26x22 <sup>5</sup> / <sub>8</sub>	660x574	68	1727	Polyurethane	56	25.2	<b>PT1C-5MP*</b>
<b>Adjustable Single-Bay</b>							
26x20 <sup>5</sup> / <sub>8</sub> to 29 <sup>3</sup> / <sub>8</sub>	523 to 746x660	68	1727	Resilient	54	24.3	<b>APT1C-5M</b>
26x20 <sup>5</sup> / <sub>8</sub> to 29 <sup>3</sup> / <sub>8</sub>	523 to 746x660	68	1727	Polyurethane	54	24.3	<b>APT1C-5MP</b>
<b>Double-Bay</b>							
26x41 <sup>3</sup> / <sub>4</sub>	660x1060	68	1727	Resilient	73	32.8	<b>PT2C-5M**</b>
26x41 <sup>3</sup> / <sub>4</sub>	660x1060	68	1727	Polyurethane	73	32.8	<b>PT2C-5MP**</b>
<b>Triple-Bay</b>							
26x60 <sup>7</sup> / <sub>8</sub>	660x1545	68	1727	Resilient	117	52.6	<b>PT3C-5M***</b>
26x60 <sup>7</sup> / <sub>8</sub>	660x1545	68	1727	Polyurethane	117	52.6	<b>PT3C-5MP***</b>

Each carrier has two brake casters and two swivel casters.

\*Single-bay carriers are equipped with six S3C single slides (3 sets)

\*\*Double-bay carriers are equipped with six S3C single slides (3 sets) and three S4C double slides.

\*\*\*Triple-bay carriers are equipped with six S3C single slides (3 sets) and six S4C double slides (3 sets). Also available without slides.  
Order with catalog numbers PTN1, PTN2, PTN3.



**PT2C**  
(Shown with totes, not included)

**STANDARD UNIT: INSIDE CLEARANCES**

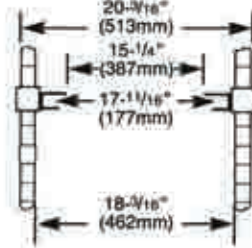

**ADJUSTABLE UNIT: SLIDE SECTION ONLY**

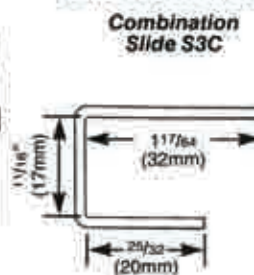

**INSIDE CLEARANCES 8-3/4" (222mm) ADJUSTABILITY**

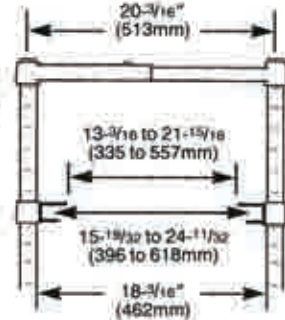

**Extra Slides**

Width/Length		Description	Approx. Pkd. Wt.		Cat. No.
(in.)	(mm)		(lbs.)	(kg)	
7/8x24	17x610	Combination Single Slide	1.5	.67	<b>S3C</b>
7/8x24	17x610	Combination Double Slide	1.6	.72	<b>S4C</b>
		End Stops for the S3C Slide			<b>9950Z</b>



**PT3C**  
(Shown with totes, not included)

# METRO STORAGE AND TRANSPORT CARTS



Starsys  
(See pages 140-173)



Super Adjustable™/Super Erecta Wire  
(See pages 220-222)



MetroMax i Polymer  
(See pages 223-225)



Totes, Slides and Bins  
(See pages 62, 226-227)



Linen Clean/Soiled  
(See pages 228-229)

## Super Adjustable™ Super Erecta® and Original Super Erecta Storage and Transport Carts

- Open wire construction allows light penetration and minimizes dust accumulation.
- Shelves can be easily repositioned on 1" (25mm) increments with the patented release lever.
- Available with stem casters or heavy-duty dolly base.
- A wide variety of accessories to customize to your exact needs.
- Multiple shelf and post sizes to fit any application.
- Solid bottom shelves or inlays available to meet infection control standards.
- Cart covers available to protect cart contents.
- Choose from a pre-configured cart or build one by component to your specifications.



Super Adjustable™ Supply Cart configured with ledges, dividers, Metro Bins, Super Erecta Slide System and Metro Totes.



Super Adjustable™ close-up. Just lift the release at each corner. Reposition in seconds.

### Metro Fact:

Any cart can be configured with Super Adjustable™ or "original" Super Erecta shelves. Super Adjustable™ offers the convenient release handle for easier positioning.



Super Erecta Transport Cart configured with the Super Erecta Slide System and Metro Totes. Cart covers are available in Mariner Blue or White to help keep cart contents secure and clean.



Super Erecta Exchange Cart configured with Metro Bins, ledges, dividers and the Super Erecta Slide System with Metro Totes.

## Build-A-Cart Super Adjustable™ Chrome

Super Adjustable™ shelves allow you to configure a cart to your specific needs and easily reposition them as needs change. A solid bottom shelf protects bottom shelf contents.



### 1 Choose Shelf

Dimensions (in.) (mm)		Top/Intermediate Wire Shelves Cat. No.	Bottom Solid Shelf Cat. No.
24x36	610x914	<b>A2436NC</b>	<b>2436FG</b>
24x42	610x1066	<b>A2442NC</b>	<b>2442FG</b>
24x48	610x1219	<b>A2448NC</b>	<b>2448FG</b>
24x60	610x1524	<b>A2460NC</b>	<b>2460FG</b>

Additional shelves may be found on pages 37 and 67.

### 2 Choose Four Posts

(in.)	(mm)	Description	Cat. No.
62	1575	Stem Caster Post	<b>63UP</b>
74	1880	Stem Caster Post	<b>74UP</b>

Additional posts may be found on page 37.

### 3 Choose Four Stem Casters

Wheel Diameter (in.) (mm)	Description	Cat. No.
5 127	Polyurethane Tread, Swivel	<b>5MP</b>
5 127	Polyurethane Tread, Swivel/Brake	<b>5MPB</b>

Additional casters may be found on page 50.

### 4 Choose 8" High (203mm) Shelf Divider

(in.)	(mm)	Description	Cat. No.
24x8	610x203	8" H. (203mm) Wire Shelf Divider	<b>DD24C</b>
24x9	610x204	8" H. (203mm) Solid Shelf Divider	<b>DD24FC</b>

### 5 Choose 4" High (102mm) Stackable Ledges

(in.)	(mm)	Description	Cat. No. Wire Shelf	Cat. No. Solid Shelf
24	610	Ledge for 24" (610mm) Shelf	<b>L24N-4C</b>	<b>L24WC</b>
36	914	Ledge for 36" (914mm) Shelf	<b>L36N-4C</b>	<b>L36WC</b>
42	1066	Ledge for 42" (1066mm) Shelf	<b>L42N-4C</b>	<b>L42WC</b>
48	1219	Ledge for 48" (1219mm) Shelf	<b>L48N-4C</b>	<b>L48WC</b>

Enclosure panels available. See page 56.

### 6 Choose Additional Accessories

(in.)	(mm)	Description	Cat. No.
10 <sup>1</sup> / <sub>4</sub> x20 <sup>3</sup> / <sub>8</sub> x21 <sup>5</sup> / <sub>8</sub>	256x510x537	Tote Slide for 24" D. (610mm) Shelf	<b>SS2NC</b>
22 <sup>1</sup> / <sub>2</sub> x17 <sup>1</sup> / <sub>2</sub>	572x445	6" H. (152mm) White Tote	<b>MTB93060W</b>
		Tote Short Divider	<b>MDS93060NAT</b>
		Tote Long Divider	<b>MDL93060NAT</b>
3x1 <sup>1</sup> / <sub>4</sub>	75x32	Label Holder	<b>9990P</b>
24	610	24" D. (610mm) Cart Handle	<b>PH24NC</b>

Additional accessories may be found on pages 55-62.

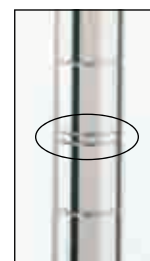

SiteSelect™ Posts are grooved at 1" (25mm) increments and numbered at 2" (50mm) increments. Posts are double-grooved every 8" (203mm) for easy identification.



5MP

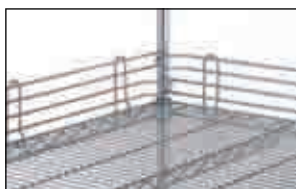

4" (100mm) Ledge



Shelf Divider for Wire Shelves



1<sup>1</sup>/<sub>4</sub>" (32mm) Label Holder



6"H (152mm) White Tote

See pages 55-62 for a complete selection of accessories.



ECN56CA — Standard (Par Level)

Super Adjustable™ Super Erecta® Exchange Carts — 30.05

Super Adjustable™ Super Erecta Shelves have a patented release lever to allow for easy reconfiguration of shelves as supply dimensions change. Carts within each series (as noted) feature dividers, ledges, enclosure panels, Super Erecta® Slides and tote boxes in various combinations, all of which can be removed and reconfigured to adapt to changes in supply, volume, and packaging.

Also available in stainless steel. Cart covers are available.

Par Level/Stock

For moveable storage of supplies in nursing units and other functional departments. Par Level carts utilize stem casters to provide a smaller footprint for more efficient space utilization in storage areas.

Standard

With four chrome-plated Super Adjustable™ wire shelves, one solid bottom shelf, chrome-plated posts, 5" (127mm) high-modulus donut stem casters (two with brakes), and six label holders.

Shelf Width/Length (in.)	Shelf Width/Length (mm)	Overall Height (in.)	Overall Height (mm)	Cat. No. with Galvanized Bottom Shelf	Cat. No. with Stainless Bottom Shelf
21x48	530x1219	67 <sup>7</sup> / <sub>8</sub>	1724	ECN45CA	ECM45XA
21x60	530x1524	67 <sup>7</sup> / <sub>8</sub>	1724	ECN46CA	ECM46XA
24x48	610x1219	67 <sup>7</sup> / <sub>8</sub>	1724	ECN55CA	ECM55XA
24x60	610x1524	67 <sup>7</sup> / <sub>8</sub>	1724	ECN56CA	ECM56XA



ECM56CD — Deluxe Par Level

Deluxe

With four chrome-plated Super Adjustable™ wire shelves, one solid bottom shelf, chrome-plated posts, 5" (127mm) high-modulus donut stem casters (two with brakes), side and back enclosure panels, one or two Super Slides, two or four 6" (152mm) deep tote boxes with box dividers, four or six shelf dividers and twelve label holders.

Shelf Width/Length (in.)	Shelf Width/Length (mm)	Overall Height (in.)	Overall Height (mm)	Tote Boxes 6" (152mm) Deep	Shelf Dividers	Super Slides	Cat. No. with Galvanized Bottom Shelf	Cat. No. with Stainless Bottom Shelf
24x48	610x1219	67 <sup>7</sup> / <sub>8</sub>	1724	2	4	1	ECN55CD	ECM55XD
24x60	610x1524	67 <sup>7</sup> / <sub>8</sub>	1724	4	6	2	ECN56CD	ECM56XD

Transport/Exchange

For transport and exchange of supplies or linens from Central Supply or the Laundry to nursing units and other functional departments. Transport carts utilize a dolly base to endure the rigors encountered in the daily distribution of products throughout healthcare facilities.

Standard

With four chrome-plated Super Adjustable™ wire shelves, one solid bottom shelf, chrome-plated posts, aluminum dolly frame with wraparound bumper, 8" (203mm) resilient casters (two with swivel locks), and six label holders.

Shelf Width/Length (in.)	Shelf Width/Length (mm)	Overall Height (in.)	Overall Height (mm)	Cat. No. with Galvanized Bottom Shelf	Cat. No. with Stainless Bottom Shelf
21x48	530x1219	71 <sup>11</sup> / <sub>16</sub>	1821	ECN45CS	ECM45XS
21x60	530x1524	71 <sup>11</sup> / <sub>16</sub>	1821	ECN46CS	ECM46XS
24x48	610x1219	71 <sup>11</sup> / <sub>16</sub>	1821	ECN55CS	ECM55XS
24x60	610x1524	71 <sup>11</sup> / <sub>16</sub>	1821	ECN56CS	ECM56XS



ECN56CC — (Deluxe Transport)

Deluxe

With four chrome-plated Super Adjustable™ wire shelves, one solid bottom shelf, chrome-plated posts, aluminum dolly frame with wraparound bumper, 8" (203mm) resilient casters (two with swivel locks), side and back enclosure panels, one or two Super Slides, two or four 6" (152mm) deep tote boxes with box dividers, four or six shelf dividers and twelve label holders. Overall height: 71<sup>11</sup>/<sub>16</sub>" (1821mm).

Shelf Width/Length (in.)	Shelf Width/Length (mm)	Tote Boxes 6" (152mm) Deep	Shelf Dividers	Super Slides	Cat. No. with Galvanized Bottom Shelf	Cat. No. with Stainless Bottom Shelf
24x48	610x1219	2	4	1	ECN55CC	ECM55XC
24x60	610x1524	4	6	2	ECN56CC	ECM56XC

MetroMax i® Storage and Transport Carts



- Lightweight polymer construction.
- Lifetime guarantee against rust.
- Choice of open grid or solid shelves that hold up to 800 lbs. (363kg).
- Shelves are adjustable in 1/2" (13mm) increments.
- Available with stem casters or heavy-duty dolly base.
- Bumpers protect walls and doorways.
- A wide variety of accessories including ledges, dividers, totes, drop-in baskets, bins and more.
- Removable shelf mats promote easy cleaning.
- All MetroMax i Shelving comes standard with \*Microban® antimicrobial product protection.

\*MICROBAN® and the MICROBAN® symbol are registered trademarks of the Microban Products Company, Huntersville, NC.



Metro incorporates several elements in its product design to support a facility's infection control processes:

- Microban® antimicrobial protection helps keep products "cleaner between cleanings"
  - Advanced polymer and other proprietary finishes provide corrosion resistance
  - Smooth rounded corners to allow for easier cleaning
- Look for the "red check" symbol for this added protection.



MetroMax i stem caster cart provides organization and easy access to sterile packs.



MetroMax i stem caster cart with Super Slides, tote boxes and lift-out baskets allow storage of a wide range of supplies.



MetroMax i heavy-duty linen cart, mounted on a smooth-rolling aluminum dolly with 6" (152mm) casters, stores and transports sheets and blankets, with ease.



ECP55CX3 — Standard (Par Level)

### MetroMax i Exchange Carts

MetroMax polymer carts provide a smooth surface that won't snag sterile packs or sealed supplies. The shelves also contain Microban antimicrobial protection that keeps the shelves cleaner between cleanings (see Index Microban protection). Carts within each series (as noted) feature dividers, ledges, enclosure panels, MetroMax slides and tote boxes in various combinations all of which can be removed and reconfigured to adapt to changes in supply, volume and packaging.

#### Par Level/Stock

For moveable storage of supplies in nursing units and other functional departments. Par Level carts utilize stem casters to provide a smaller footprint for more efficient space utilization in storage areas.

#### Standard

Includes four open grid shelves, one solid bottom shelf, polymer posts, four polyurethane stem casters (2 with brakes) and six label holders.

Shelf Width/Length (in./mm)		Overall Height (in./mm)		Cat. No.
18x48	457x1219	67 <sup>5</sup> / <sub>16</sub>	1710	ECP35CX3
18x60	457x1524	67 <sup>5</sup> / <sub>16</sub>	1710	ECP36CX3
24x48	610x1219	67 <sup>5</sup> / <sub>16</sub>	1710	ECP55CX3
24x60	610x1524	67 <sup>5</sup> / <sub>16</sub>	1710	ECP56CX3



ECT55CX3 — Standard Transport/Exchange

#### Deluxe

Includes four open grid shelves, one solid bottom shelf, polymer posts, four polyurethane stem casters (2 with brakes), side and back enclosure panels, MetroMax tote slides, 6" (152mm) deep tote boxes with dividers, shelf dividers and twelve label holders.

Shelf Width/Length (in./mm)		Overall Height (in./mm)		Cat. No.
24x48	610x1219	67 <sup>5</sup> / <sub>16</sub>	1710	ECP55DX3
24x60	610x1524	67 <sup>5</sup> / <sub>16</sub>	1710	ECP56DX3

#### Transport/Exchange

For transport and exchange of supplies or linens from Central Supply or the Laundry to nursing units and other functional departments. Transport carts utilize a dolly base to endure the rigors encountered in the daily distribution of products throughout healthcare facilities.

#### Standard

Includes four open grid shelves, one solid bottom shelf, polymer posts, aluminum dolly frame with wraparound bumper, 8" (203mm) high modulus donut casters (two with swivel-locks), and six label holders.

Shelf Width/Length (in./mm)		Overall Height (in./mm)		Cat. No.
24x48	610x1219	71 <sup>15</sup> / <sub>16</sub>	1827	ECT55CX3
24x60	610x1524	71 <sup>15</sup> / <sub>16</sub>	1827	ECT56CX3



ECT55DX3 — Deluxe Transport/Exchange

#### Deluxe

Includes four open grid shelves, one solid bottom shelf, polymer posts, aluminum dolly frame with wraparound bumper, 8" (203mm) high modulus donut casters (two with swivel-locks), side and back enclosure panels, MetroMax tote slides, 6" (152mm) deep tote boxes with dividers, shelf dividers and twelve label holders.

Shelf Width/Length (in./mm)		Overall Height (in./mm)		Cat. No.
24x48	610x1219	71 <sup>15</sup> / <sub>16</sub>	1827	ECT55DX3
24x60	610x1524	71 <sup>15</sup> / <sub>16</sub>	1827	ECT56DX3

Indicates antimicrobial product.

Extended Handles for MetroMax i Mobile Systems — 10.05

These contoured stainless steel handles attach easily to 18" or 24" (457 or 610mm) MetroMax® carts, dolly trucks and other mobile applications.

Fits Unit Width (in.) (mm)		Approx. Pkd. Wt. (lbs.) (kg)		Cat. No.
18	457	2¼	1.0	<b>MEH18S</b>
24	610	2½	1.1	<b>MEH24S</b>

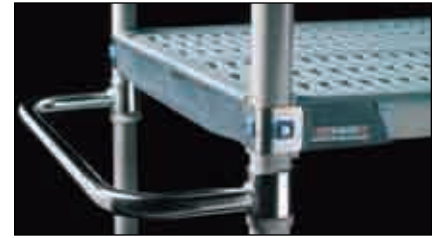

Extended Handle

MetroMax i I.V. Transport/Storage System

The Perfect Solution For: Exchange System, Par Level Storage, Bulk Storage in Central Supply, Pharmacy Admixture, I.C.U. and E.R. Storage. Baskets have semi-open front for easy access. Dividers adjust horizontally within the basket to accept various sizes of I.V. bags. Continuous label holders identify basket contents.

Description	Height/Width/Length (in.) (mm)		Total Baskets Per Cart	Casters	Cat. No.
Open Cart	24x24x60	610x610x1524	4	*	<b>MXIV1</b>
Open Cart with Top Shelf	24x24x69	610x610x1753	4	*	<b>MXIV2</b>
Open Cart	24x42x60	610x1066x1524	8	†	<b>MXIV4</b>
Open Cart with Top Shelf	24x42x69	610x1066x1753	8	†	<b>MXIV5</b>
Open Cart	24x60x60	610x1524x1524	12	†	<b>MXIV6</b>
Open Cart with Top Shelf	24x60x69	610x1524x1753	12	†	<b>MXIV7</b>

\*Four 5" (127mm) poly casters; two swivel, two with brakes.  
 †5"(127mm) poly casters on dolly frame; two swivel, one swivel with brake, and one rigid.



MXIV1 (includes accessories as shown)

Accessories

Description	Size (in.) (mm)		Cat. No.
Basket* with Label Holder	18½x24½x10	470x622x254	<b>IVB1</b>
Divider	9	229	<b>IVBD</b>

\*Basket weight capacity is 35 lbs. (16kg).



IVB1 (shown with optional Divider)

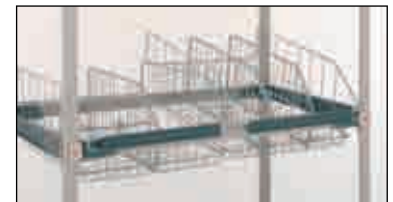

Baskets fit on frames level or at a 10° angle.

Note: See pages 22-28 for the complete line of MetroMax i accessories.

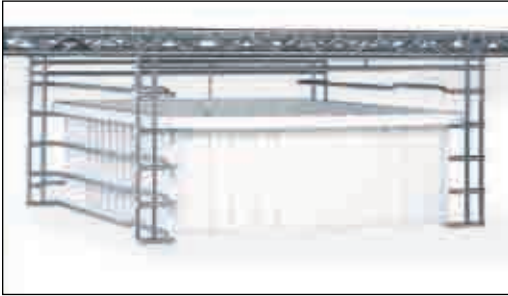

Super Erecta Slide System in place on shelf (Tote boxes sold separately)

**Super Erecta® Slide System — 10.07**

A super space-saving solution. Using Super Erecta® wire units 21" or 24" (530 and 610mm) wide, tote boxes and this innovative slide system, you have the flexibility to create a custom configuration that can be positioned quickly on new or existing units without the use of tools. Finish is nickel-chrome wire with clear protective coating.

Outside Slide Dimensions Height/Width/Length (in.) (mm)		Fits Shelf (in.) (mm)		Adaptable Boxes	Approx. Pkd. Wt. (lbs.) (kg)		Cat. No.
10 <sup>1</sup> / <sub>4</sub> x20 <sup>3</sup> / <sub>8</sub> x21 <sup>5</sup> / <sub>8</sub>	256x510x537	24	610	MTB93030W, MTB93060W MTB93080W	4 <sup>3</sup> / <sub>4</sub>	2.1	<b>SS2NC</b>
10 <sup>1</sup> / <sub>4</sub> x14x17 <sup>1</sup> / <sub>8</sub>	256x355x430	21	530	MTB92035W, MTB92060W, MTB92080W	3 <sup>1</sup> / <sub>2</sub>	1.5	<b>SS3NC</b>
10 <sup>1</sup> / <sub>4</sub> x25 <sup>1</sup> / <sub>8</sub> x17 <sup>1</sup> / <sub>8</sub>	256x630x430	21	530	MTB93030W,* MTB93060W,* MTB93080W*	4	1.8	<b>SS4NC</b>

\*Fits SS4NC with box turned sideways.

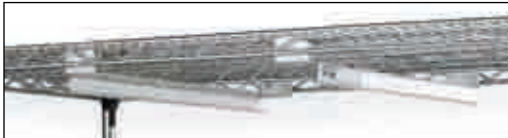

Adjustable Underslide Shelf

**Adjustable Underslide Slides — 10.05**

These slides can be spaced under wire shelves to fit ANY width container or tote box.

Item	Approx. Pkd. Wt. (lbs.) (kg)		Cat. No. (pair)
For 18" (457mm) wide shelf	1	0.4	<b>US18NA</b>
*For 21" (530mm) wide shelf	1	0.4	<b>US21NA</b>
For 24" (610mm) wide shelf	1	0.4	<b>US24NA</b>

\*Not adaptable to 24" (610mm) long shelf.



One-Piece Slides

**One-Piece Slides — 10.05**

Puts space to work with tote boxes. One-piece solid slide attaches easily to wire shelf with support brackets. Tote boxes can be compartmentalized with dividers.

FOR MTB93030W, MTB93060W, MTB93080W				
For Shelf Width (in.) (mm)		Approx. Pkd. Wt. (lbs.) (kg)		Cat. No.
18	457	4 <sup>3</sup> / <sub>4</sub>	2.13	<b>BSD2218NA</b>



Adjustable Underslide Slides for Super Erecta Solid Shelf

**Adjustable Underslide Slides for Solid Shelves — 10.25**

Create a convenient drawer system by combining a tote box and these slides. Two slides are required, and can be spaced to fit any width container.

Item	Approx. Pkd. Wt. (lbs.) (kg)		Cat. No. Solid
For 18" (457mm) wide shelf	1	0.4	<b>US18FA</b>
*For 21" (530mm) wide shelf	1	0.4	<b>US21FA</b>
For 24" (610mm) wide shelf	1	0.4	<b>US24FA</b>

\*Not adaptable to 24" (610mm) long shelf.

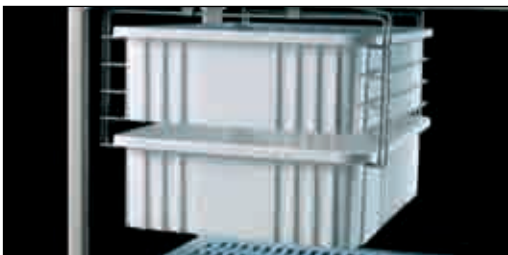

MetroMax i Super Slide shown with Tote Boxes (sold separately)

**MetroMax i® Super Slides — 9.05**

Quickly attach to 24" (610mm) wide MetroMax i shelves. Accepts 3", 6" and 9" (76, 152 and 230mm) deep tote boxes in combination up to 15" (381mm) high. Corrosion-resistant taupe epoxy finish with Microban antimicrobial product protection.

Width/Length (in.) (mm)		Height (in.) (mm)	Approx. Pkd. Wt. (lbs.) (kg)		Cat. No. Chrome
20 <sup>3</sup> / <sub>8</sub> x21 <sup>5</sup> / <sub>8</sub>	520x550	10 <sup>1</sup> / <sub>4</sub>	260	5 <sup>1</sup> / <sub>4</sub> 2	<b>MXSS2E</b>



One-Piece Underslide Shelf with Tote Box (Tote Box sold separately)

**MetroMax i® One-Piece Underslide Slides — 9.05**

Innovative design lets you suspend tote boxes (see chart below) below 18" and 24" (457 and 610mm) wide MetroMax i shelves to create a more versatile storage system.

Fits Shelf (in.) (mm)		Approx. Pkd. Wt. (lbs.) (kg)		Cat. No.
18	457	3 <sup>1</sup> / <sub>4</sub>	1.5	<b>BSD2218XA</b>
24	610	3 <sup>3</sup> / <sub>4</sub>	1.52	<b>BSD2224XB</b>

See page 227 for Tote Boxes.

MetroTotes Divider Box Line — 16.64

Metro's Divider Tote Box Line offers safe and efficient storage of items in bulk, or in compartmentalized fashion with the use of optional dividers. Manufactured of polypropylene material, these injection-molded totes are available in white and can be stored and transported in a variety of standard Metro products (e.g. PT Slide Trucks, Super Slide System, etc.).



Outside Dimensions (includes lip) Length x Width (in.)		Inside Dimensions Length x Width (in.)		Height O.D. (in.)		I.D.* (in.)		Capacity (cu. ft.) (cu. m.)		Approx. Tote Box Wt. (lbs.)	Cat. No.
10 <sup>7</sup> / <sub>8</sub> x8 <sup>1</sup> / <sub>4</sub>	276x210	9 <sup>1</sup> / <sub>8</sub> x6 <sup>1</sup> / <sub>2</sub>	232x165	3 <sup>1</sup> / <sub>2</sub>	89	3	76	.10	0.003	.77	<b>MTB91035W</b>
16 <sup>1</sup> / <sub>2</sub> x10 <sup>7</sup> / <sub>8</sub>	419x276	14 <sup>7</sup> / <sub>8</sub> x9 <sup>1</sup> / <sub>4</sub>	378x235	3 <sup>1</sup> / <sub>2</sub>	89	3	76	.24	0.007	1.5	<b>MTB92035W</b>
16 <sup>1</sup> / <sub>2</sub> x10 <sup>7</sup> / <sub>8</sub>	419x276	14 <sup>7</sup> / <sub>8</sub> x9 <sup>1</sup> / <sub>4</sub>	378x235	6	152	5.5	140	.44	0.012	2.33	<b>MTB92060W</b>
22 <sup>1</sup> / <sub>2</sub> x17 <sup>1</sup> / <sub>2</sub>	572x445	20 <sup>1</sup> / <sub>4</sub> x15 <sup>1</sup> / <sub>8</sub>	514x384	3	76	2.5	64	.44	0.017	2.57	<b>MTB93030W</b>
22 <sup>1</sup> / <sub>2</sub> x17 <sup>1</sup> / <sub>2</sub>	572x445	20 <sup>1</sup> / <sub>4</sub> x15 <sup>1</sup> / <sub>8</sub>	514x384	5	127	4.5	114	.79	0.02	4.0	<b>MTB93050W</b>
22 <sup>1</sup> / <sub>2</sub> x17 <sup>1</sup> / <sub>2</sub>	572x445	20 <sup>1</sup> / <sub>4</sub> x15 <sup>1</sup> / <sub>8</sub>	514x384	6	152	5.5	140	.97	0.027	4.0	<b>MTB93060W</b>
22 <sup>1</sup> / <sub>2</sub> x17 <sup>1</sup> / <sub>2</sub>	572x445	20 <sup>1</sup> / <sub>4</sub> x15 <sup>1</sup> / <sub>8</sub>	514x384	8	203	7.5	191	1.32	0.037	5.25	<b>MTB93080W</b>
22 <sup>1</sup> / <sub>2</sub> x17 <sup>1</sup> / <sub>2</sub>	572x445	20 <sup>1</sup> / <sub>4</sub> x15 <sup>1</sup> / <sub>8</sub>	514x384	12	305	11.5	292	2.03	0.057	6.67	<b>MTB93120W</b>

\*Loading height restrictions when using covers or stacking totes.

MetroTote Accessories — 16.64

Covers and Dividers

For Tote Box	Insert Cover	Dividers	Maximum Tote
MTB91035W	<b>CI91000CLR</b>	Short <b>MDS91035NAT</b>	7
		Long <b>MDL91035NAT</b>	5
MTB92035W	<b>CI92000CLR</b>	Short <b>MDS92035NAT</b>	11
		Long <b>MDL92035NAT</b>	7
MTB92060W	<b>CI92000CLR</b>	Short <b>MDS92060NAT</b>	11
		Long <b>MDL92060NAT</b>	7
MTB93030W	<b>CI93000CLR</b>	Short <b>MDS93030NAT</b>	15
		Long <b>MDL93030NAT</b>	11
MTB93060W	<b>CI93000CLR</b>	Short <b>MDS93060NAT</b>	15
		Long <b>MDL93060NAT</b>	11
MTB93080W	<b>CI93000CLR</b>	Short <b>MDS93080NAT</b>	15
		Long <b>MDL93080NAT</b>	11
MTB93120W	<b>CI93000CLR</b>	Short <b>MDS93080NAT</b>	15
		Long <b>MDL93080NAT</b>	11

Snap-On Card Holder

Clear vinyl with clear window.

Size (in.)	Size (mm)	Cat. No.
4 <sup>1</sup> / <sub>2</sub> x8	114x199	<b>OP2501CLR</b>
4 <sup>1</sup> / <sub>2</sub> x8	114x199	<b>OP2501CLR</b>
4 <sup>1</sup> / <sub>2</sub> x8	114x199	<b>OP2501CLR</b>
4 <sup>1</sup> / <sub>2</sub> x8	114x199	<b>OP2501CLR</b>

Shelf Spacing

To determine the spacing required between shelves, total the depths of the tote boxes chosen for a given slide, and add 4" (102mm) to that total. The table below illustrates tote box combinations and their corresponding shelf spacing.

Tote Box Combinations (Per Slide)

Tote Box Depths	(in.)	3 + 6	6 + 6	3 + 8	6 + 8	3 + 3 + 3	3 + 3 + 6	3 + 3 + 8
	(mm)	75 + 152	152 + 152	75 + 203	152 + 203	75 + 75 + 75	75 + 75 + 152	75 + 75 + 203
Shelf Spacing Required	(in.)	13	16	15	18	13	16	18
	(mm)	330	406	381	457	330	406	457

See page 226 for slides.



Vertical Placement utilizing Super Erecta Slide System

Slide System Guide

Tote Series	Compatible Slides		
	Super Erecta System	Super Adjustable or MetroMax	MetroMax Q
MTB91	US (18, 21 or 24) NA US (18, 21 or 24) FA		
MTB92	SS3NC, US (18, 21 or 24) NA		
MTB93	SS2NC, SS4NC	SS2XE BSD2218XA, BSD2224XB	QSS2E
	US (18, 21 or 24) NA		
	US (18, 21 or 24) FA		
	BSD2218NA, BSD2224NB		
MTB95	US (18, 21 or 24) NA		
	US (18, 21 or 24) FA		



LXH56C Heavy-Duty

### Linex Exchange/Transport Carts

Linex Exchange/Transport Cart is available in a heavy-duty model. Features enclosure panels and 6" (152mm) plate casters with a brake/lock mechanism mounted on a dolly frame.

Shelf Width/Length (mm)		Height (mm)		Approx. Pkd. Wt. (kg)		Cat. No.
(in.)	(mm)	(in.)	(mm)	(lbs.)	(kg)	
24x60	610x1524	70 <sup>11</sup> / <sub>16</sub>	1780	185	84	<b>LXH56C</b>

For additional Linex Exchange Carts, Accessories or Configurations, please consult your Metro representative.

See pages 220-222 for additional wire transport carts.



LXH56CX3 shown with optional ledges

### MetroMax i® Polymer Linex Exchange/Transport Carts

Corrosion-Proof Linex Exchange/Transport Cart is available in a heavy-duty model. Offers 6" (152mm) plate casters with a brake/lock mechanism mounted on a dolly frame. Shelf mats now include Microban® antimicrobial technology that inhibits the growth of bacteria, mold or fungus that cause odors and stains.

Shelf Width/Length (mm)		Height (mm)		Description	Approx. Pkd. Wt. (kg)		Cat. No.
(in.)	(mm)	(in.)	(mm)		(lbs.)	(kg)	
24x60	610x1524	70 <sup>9</sup> / <sub>16</sub>	1786	Heavy-Duty	185	84	<b>LXH56CX3</b>

See pages 223-225 for additional polymer transport carts.



SXR76CM3 Starsys Enclosed Linex Exchange Cart

### Starsys™ Enclosed Linex Exchange Cart

Polymer doors, sides and backs won't rust, dent, chip or peel. Enclosed environment provides efficient contamination-free handling and distribution of linens. Cart consist of four stationary shelves, non-locking 270 degree swing doors, 5" (127mm) polyurethane swivel casters (two with brakes).

Shelf Width/Length (mm)		Height (mm)		Approx. Pkd. Wt. (kg)		Cat. No.
(in.)	(mm)	(in.)	(mm)	(lbs.)	(kg)	
22x40	559x1016	76	1930	312	142	<b>SXR76CM3</b>

#### Additional Shelves

Fits	Cat. No.
Stationary QuikSLOT	<b>SXR76WQ</b>
Full Extension	<b>SXR76WAR</b>

See page 152 for additional Starsys carts.

Convertible Linen Truck — 31.12

Versatile construction allows folding shelves to be positioned horizontally or vertically. Brake Lock/Swivel Lock combination casters increase flexibility. Open wire design maximizes air circulation and visibility.

Shelf Size Width/Length (in.) (mm)		Height (in.) (mm)		Description	Approx. Pkd. Wt. (lbs.) (kg)		Cat. No.
Standard-Duty — Chrome							
24x60	610x1524	70 <sup>1</sup> / <sub>16</sub>	1780	CLT with 3-sided top frame	200	90	<b>CLTS2460C</b>
24x48	610x1219	70 <sup>1</sup> / <sub>16</sub>	1780	CLT with 3-sided top frame	180	81	<b>CLTS2448C</b>
Standard-Duty — Stainless Steel							
24x60	610x1524	70 <sup>1</sup> / <sub>16</sub>	1780	CLT with 3-sided top frame	169	76	<b>CLT2460S</b>
Heavy-Duty — Chrome							
24x60	610x1524	70 <sup>1</sup> / <sub>16</sub>	1780	CLT with 3-sided top frame	241	108	<b>CLTH2460C</b>

**Material:** Chrome Models: Chrome-plated steel dolly and aluminum tubes.  
Stainless Steel: Stainless steel dolly and aluminum tubes.  
**Note 1:** Casters on above units consist of two 6P and one pair BL6P, 8P and BL8P available on special order.  
**Note 2:** Before employing any of various cart-washing systems, please contact InterMetro Corporation or your InterMetro representative for special recommendations on casters and for cleaning instructions.

Accessories

Description	Model
Card Holder	<b>CLCHC</b>
Push Handle	<b>PH24NC</b>



Standard-Duty Convertible Linen Truck



MetroTrux™ Convertible Linen Trux — 31.42

Exclusive integral, convertible shelving system in a polymer truck. Two folding shelves can be positioned horizontally or vertically to produce three different configurations: horizontal shelves for bulk items or linens; vertical for collecting and transporting bulk materials; and with lower shelf flipped up and out for easy loading and unloading. Advanced polymer design will not dent, rust or corrode.

Width/Length (in.) (mm)		Height (in.) (mm)		Description	6" (152mm) Casters	Cat. No.
28 <sup>1</sup> / <sub>4</sub> x48	724x1219	68 <sup>1</sup> / <sub>4</sub>	1736			
28 <sup>1</sup> / <sub>4</sub> x48	724x1219	68 <sup>1</sup> / <sub>4</sub>	1736	48 cu. ft. (1.36 cu. m.) capacity	2 rigid; 2 swivel	<b>CLT48A</b>



Convertible Linen Trux

MetroTrux™ Bulk Trux — 31.42

The perfect solution for storing and transporting bulky, hard-to-handle items, such as bagged dirty laundry. Available in 48 cubic foot (1.36 cubic meter) capacity. Advanced polymer design will not dent, rust or corrode.

Width/Length (in.) (mm)		Height (in.) (mm)		Description	6" (152mm) Casters	Cat. No.
28 <sup>1</sup> / <sub>4</sub> x48	724x1219	68 <sup>1</sup> / <sub>4</sub>	1736			
28 <sup>1</sup> / <sub>4</sub> x48	724x1219	68 <sup>1</sup> / <sub>4</sub>	1736	48 cu. ft. (1.36 cu. m.) capacity	2 swivel; 2 rigid	<b>BT48A</b>

**Note:** Drain holes are standard on Bulk Trux. If drain holes are not desired, indicate at time of order.



Bulk Trux



# WORK STATIONS

Process Tables & Accessories .....	232-235
Worktables & Accessories.....	236-237

## Ergonomic Process Tables — 52.03

Built for cleanliness and stability.

- Seamless 14-gauge Type 304 stainless steel work surface and support structure.
- Shipped knocked down and can be assembled in minutes without tools.
- Ergonomic design features bull nose front and back edge.



LTSM30IS shown with casters (casters sold separately)

### Ergonomic Process Tables 30" (760mm) Wide

Work Surface Length (in.)		Work Surface Height Stationary (mm)		Mobile (mm)		Approx. Pkd. Wt. (lbs.) (kg)		Bottom Structure Solid HD Shelf 3-Sided Frame		Cat. No. Stationary	Cat. No. Mobile
29.750	755	35.375	898	35.188	893	65	30	SS		LTS30IS	LTSM30IS
35.750	908	35.375	898	35.188	893	80	36	SS		LTS36IS	LTSM36IS
47.750	1212	35.375	898	35.188	893	103	47	SS		LTS48IS	LTSM48IS
59.750	1517	35.375	898	35.188	893	140	63	SS		LTS60IS	LTSM60IS
29.750	755	35.375	898	35.188	893	65	30		SS	LTS30UIS	LTSM30UIS
35.750	908	35.375	898	35.188	893	80	36		SS	LTS36UIS	LTSM36UIS
47.750	1212	35.375	898	35.188	893	103	47		SS	LTS48UIS	LTSM48UIS
59.750	1517	35.375	898	35.188	893	140	63		SS	LTS60UIS	LTSM60UIS

SS = Stainless Steel.

Leveling feet on stationary units have 1.250 (31mm) vertical adjustment.

1" (25mm) diameter stem casters ordered separately.

Stainless Lab Tables are load rated at 50 lbs. per sq. foot (.024kg per sq. cm) up to a maximum of 600 lbs. (273kg) assuming evenly distributed load and caster specification meets requirement.



LTFMA LTSM60UIS shown with accessories and casters (casters sold separately)

Casters ordered separately. Refer to page 51 for Caster Selection Guide.

## Ergonomic Process Tables Accessories

### Wire Shelf

Stainless shelves mount on 3-sided frames with use of clips.



LT30WS

Fits Shelf Length (in.)		Approx. Pkd. Wt. (lbs.) (kg)		Cat. No. Stainless
22 <sup>3</sup> / <sub>8</sub>	568	6	2.7	LT30WS
28 <sup>3</sup> / <sub>8</sub>	720	7.5	3.4	LT36WS
40 <sup>3</sup> / <sub>8</sub>	1025	10	4.5	LT48WS
52 <sup>3</sup> / <sub>8</sub>	1330	12	5.4	LT60WS

Note: Shelves are load rated for a maximum of 150 lbs. (68kg).



LTSD6

### Stainless Drawer

Fits 30", 36", 48" and 60" (760, 914, 1219, and 1524mm) table lengths.

Cat. No. **LTSD6**

Note: Stainless keyboard tray and stainless drawer will both fit 60" (1524mm) long table.



LTSKB

### Stainless Keyboard Tray

Fits 48" and 60" (1219 and 1524mm) table lengths

Cat. No. **LTSKB**

Note: Stainless keyboard tray and stainless drawer will both fit 60" (1524mm) long table.

## Standard Process Tables — 17.20

Built for cleanliness and stability.

- Seamless 14-gauge Type 304 stainless steel work surface and support structure.
- Shipped knocked down and can be assembled in minutes without tools.
- All Process Tables are 34" (864mm) high with stationary posts and leveling feet.
- All Mobile Process Tables are 34" (864mm) high. Mobile units have special posts and four 5" (127mm) poly casters — 2 swivel/2 brake.

## Standard Process Tables — 30" (760mm) Wide

Length (in.) (mm)	Post Material	Bottom Shelf Material	Bottom 3-Sided Frame Material	Bottom H-Frame Material	Approx. Pkd. Wt. (lbs.) (kg)	Stationary Cat. No.	Mobile Cat. No.
48 1219	SS	SS	—	—	105 48	<b>WT305FS</b>	<b>MWT305FS</b>
60 1524	SS	SS	—	—	160 73	<b>WT306FS</b>	<b>MWT306FS</b>
72 1825	SS	SS	—	—	182 83	<b>WT307FS</b>	<b>MWT307FS</b>
96 2439	SS	SS	—	—	226 103	<b>WT309FS</b>	<b>MWT309FS</b>
60 1524	Chrome	Galvanized	—	—	146 66	<b>WT306FC</b>	<b>MWT306FC</b>
72 1825	Chrome	Galvanized	—	—	180 82	<b>WT307FC</b>	<b>MWT307FC</b>
96 2439	Chrome	Galvanized	—	—	226 103	<b>WT309FC</b>	<b>MWT309FC</b>
48 1219	SS	—	SS	—	130 59	<b>WT305US</b>	<b>MWT305US</b>
60 1524	SS	—	SS	—	139 63	<b>WT306US</b>	<b>MWT306US</b>
72 1825	SS	—	SS	—	155 71	<b>WT307US</b>	<b>MWT307US</b>
96 2439	SS	—	SS	—	201 91	<b>WT309US</b>	<b>MWT309US</b>
60 1524	SS	—	—	SS	124 56	<b>WT306HS</b>	<b>MWT306HS</b>
72 1825	SS	—	—	SS	156 71	<b>WT307HS</b>	<b>MWT307HS</b>
96 2439	SS	—	—	SS	202 92	<b>WT309HS</b>	<b>MWT309HS</b>

SS = Stainless Steel



WT306US  
Process Table with 3-Sided Frame



MWT306US  
Mobile Process Table

## Standard Process Tables — 36" (914mm) Wide

Length (in.) (mm)	Post Material	Bottom Shelf Material	Bottom 3-Sided Frame Material	Bottom H-Frame Material	Approx. Pkd. Wt. (lbs.) (kg)	Cat. No.
60 1524	SS	SS	—	—	125 57	<b>WT366FS</b>
72 1825	SS	SS	—	—	130 59	<b>WT367FS</b>
96 2439	SS	SS	—	—	185 84	<b>WT369FS</b>
60 1524	Chrome	Galvanized	—	—	125 57	<b>WT366FC</b>
72 1825	Chrome	Galvanized	—	—	130 59	<b>WT367FC</b>
96 2439	Chrome	Galvanized	—	—	185 84	<b>WT369FC</b>
60 1524	SS	—	SS	—	104 47	<b>WT366US</b>
72 1825	SS	—	SS	—	106 48	<b>WT367US</b>
96 2439	SS	—	SS	—	161 73	<b>WT369US</b>
60 1524	SS	—	—	SS	103 47	<b>WT366HS</b>
72 1825	SS	—	—	SS	107 49	<b>WT367HS</b>
96 2439	SS	—	—	SS	162 74	<b>WT369HS</b>

SS = Stainless Steel



WT366HS  
Process Table with H-Frame

See pages 234-235 for optional accessories



WT446FS  
Process Table with Bottom Shelf

## Process Tables — 17.20

### Standard Process Tables — 44" (1118mm) Wide

Length (in.) (mm)	Post Material	Bottom Shelf Material	Bottom 3-Sided Frame Material	Bottom H-Frame Material	Approx. Pkd. Wt. (lbs.) (kg)	Cat. No.
60 1524	SS	SS	—	—	136 62	WT446FS
72 1825	SS	SS	—	—	160 73	WT447FS
96 2439	SS	SS	—	—	202 92	WT449FS
60 1524	Chrome	Galvanized	—	—	136 62	WT446FC
72 1825	Chrome	Galvanized	—	—	160 73	WT447FC
96 2439	Chrome	Galvanized	—	—	202 92	WT449FC
60 1524	SS	—	SS	—	114 52	WT446US
72 1825	SS	—	SS	—	135 61	WT447US
96 2439	SS	—	SS	—	177 81	WT449US
60 1524	SS	—	—	SS	113 51	WT446HS
72 1825	SS	—	—	SS	136 62	WT447HS
96 2439	SS	—	—	SS	178 81	WT449HS

SS = Stainless Steel



WTC306FC  
(shown with optional cantilever shelf and utility rack ordered separately)

## Process Tables with Overhead — 17.26

All Process Tables with Overhead are 30" (760mm) wide and have rear posts that are approximately 88" (2235mm) high. Cantilever shelves for overhead models (shown below) are sold separately.

Length (in.) (mm)	Post Material	Bottom Shelf Material	Bottom 3-Sided Frame Material	Approx. Pkd. Wt. (lbs.) (kg)	Cat. No.
60 1524	SS	SS	—	158 71	WTC306FS
72 1825	SS	SS	—	251 114	WTC307FS
96 2440	SS	SS	—	288 131	WTC309FS
60 1524	Chrome	Galvanized	—	214 97	WTC306FC
72 1825	Chrome	Galvanized	—	251 114	WTC307FC
96 2440	Chrome	Galvanized	—	288 131	WTC309FC
60 1524	SS	—	SS	196 89	WTC306US
72 1825	SS	—	SS	230 105	WTC307US
96 2440	SS	—	SS	267 121	WTC309US

All overhead models are fitted with stationary posts and leveling feet. For overhead models in other sizes, contact your InterMetro representative. SS = Stainless Steel

## Accessories for Work Tables with Overhead — 17.26

- Additional accessories shown on page 235.



Cantilever Shelves

## Cantilever Shelves for Overhead Models

All Cantilever Shelves are 12" (317mm) wide.

Length (in.) (mm)	Fits Table (in.)	Approx. Pkd. Wt. (lbs.) (kg)	Cat. No. Chrome	Cat. No. Stainless
54 1372	60" (1524mm) long	11.8 5.3	1254CHC	1254CHS
60 1524	72" (1830mm) long & 96" (2440mm) long	12.7 5.7	1260CHC	1260CHS



Utility Rack

## Utility Racks for Overhead Models

Inside Length (in.) (mm)	Fits Tables (in.)	Finish	Approx. Pkd. Wt. (lbs.) (kg)	Cat. No.
51 <sup>9</sup> / <sub>16</sub> 1406	60 long	Chrome-Plated	7.7 3.5	654SRC
57 <sup>9</sup> / <sub>16</sub> 1406	72 long & 96 long	Chrome-Plated	8.3 3.8	660SRC



HK23C



HK23S

## Utility Hook for Cantilever Shelves

Width/Height/Depth (in.) (mm)	Finish	Approx. Pkd. Wt. (lbs.) (kg)	Cat. No.
<sup>3</sup> / <sub>8</sub> x3 <sup>7</sup> / <sub>16</sub> x1 <sup>11</sup> / <sub>16</sub> 9x87x43	Chrome	0.1 .045	HK23C
<sup>3</sup> / <sub>8</sub> x3 <sup>7</sup> / <sub>16</sub> x1 <sup>11</sup> / <sub>16</sub> 9x87x43	Stainless	0.1 .045	HK23S

## Standard Process Tables Accessories — 17.20

### Wire Shelf

Stainless shelves mount on 3-sided frames with use of clips.

Fits Shelf Length		Approx. Pkd. Wt.		Cat. No. Stainless
(in.)	(mm)	(lbs.)	(kg)	
22 <sup>3</sup> / <sub>8</sub>	568	6	2.7	<b>LT30WS</b>
28 <sup>3</sup> / <sub>8</sub>	720	7.5	3.4	<b>LT36WS</b>
40 <sup>3</sup> / <sub>8</sub>	1025	10	4.5	<b>LT48WS</b>
52 <sup>3</sup> / <sub>8</sub>	1330	12	5.4	<b>LT60WS</b>

**Note:** Shelves are load rated for a maximum of 150 lbs. (68kg).

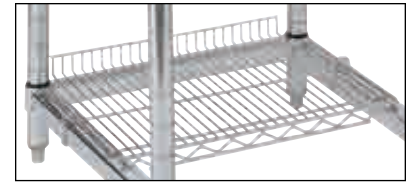

LT30WS

### Economy Drawer

Overall Dimensions Width/Length/Height		Dimensions Inside Bottom		Approx. Pkd. Wt.		Cat. No.
(in.)	(mm)	(in.)	(mm)	(lbs.)	(kg)	
14 <sup>1</sup> / <sub>4</sub> x28x5 <sup>3</sup> / <sub>4</sub>	362x711x146	10x16	254x406	6.8	3.1	<b>WTD21C</b>



Deluxe Drawer

### Deluxe Drawer

Overall Dimensions Width/Length/Height		Dimensions Inside Bottom		Approx. Pkd. Wt.		Cat. No.
(in.)	(mm)	(in.)	(mm)	(lbs.)	(kg)	
24x25 <sup>3</sup> / <sub>4</sub> x7 <sup>1</sup> / <sub>2</sub>	610x654x191	20x20	508x508	31	13.9	<b>WTD51S</b>

### 3<sup>1</sup>/<sub>2</sub>" (89mm) Foot Plates

Cat. No. **9993HS**



3<sup>1</sup>/<sub>2</sub>" (89mm) Foot Plate

### Surface Mount Swing Arm for Flat Monitor

Cat. No. **LTFMA**



LTFMA

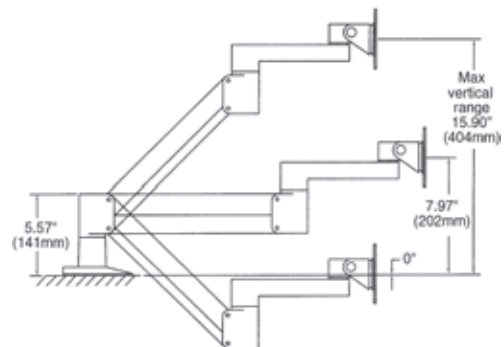
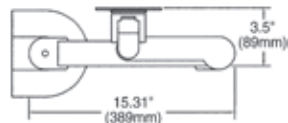
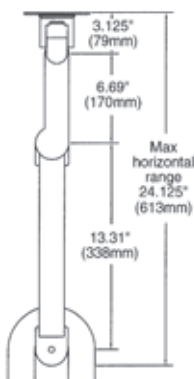



LTM60XUPG3  
(Shown with accessories, casters and Starsys Cart)



LTM30XS3  
(Featuring solid MetroMax shelf shown with optional casters)



LTM30XUS3  
(Shown with optional wire shelf and casters)



LTM60XPG3  
(Shown with backplash, accessories and casters)



LTM60XUPG3  
(Shown with accessories and casters)

MetroMaxi® Worktables — 52.01

- Corrosion-resistance advanced polymer construction.
- Smooth surfaces are easy-to-clean.
- Mobile units can be easily moved into a new configuration for cleaning.
- Available top materials include Type 304 stainless and TRESPA gray phenolic resin.
- Accessories and caster options (page 237) available for specific applications.

Stainless Steel: Worksurfaces are fabricated from Type 304 stainless steel which provides excellent protection in corrosive environments.

Worktables — Stainless Tops and Polymer Shelf

Width (in.) (mm)	Length (in.) (mm)	Work Surface Height (in.) (mm)	Overall Height (in.) (mm)	Approx. Pkd. Wt. (lbs.) (kg)	Cat. No. Stationary	Cat. No. Mobile*
30 762	29 <sup>3</sup> / <sub>4</sub> 749	35 <sup>1</sup> / <sub>2</sub> 902	39 <sup>1</sup> / <sub>2</sub> 1003	65 29	LT30XS3	LTM30XS3
30 762	35 <sup>3</sup> / <sub>4</sub> 908	35 <sup>1</sup> / <sub>2</sub> 902	39 <sup>1</sup> / <sub>2</sub> 1003	70 32	LT36XS3	LTM36XS3
30 762	47 <sup>3</sup> / <sub>4</sub> 1213	35 <sup>1</sup> / <sub>2</sub> 902	39 <sup>1</sup> / <sub>2</sub> 1003	90 41	LT48XS3	LTM48XS3
30 762	59 <sup>3</sup> / <sub>4</sub> 1517	35 <sup>1</sup> / <sub>2</sub> 902	39 <sup>1</sup> / <sub>2</sub> 1003	100 45	LT60XS3	LTM60XS3

\*Casters ordered separately. Refer to chart on next page for caster options.

Note: Worktables are load rated at 50 lbs. (23kg) per square foot up to a maximum of 600 lbs. (273kg), assuming load evenly distributed.

Worktables with Stainless Top and 3-Sided Frame

Width (in.) (mm)	Length (in.) (mm)	Work Surface Height (in.) (mm)	Overall Height (in.) (mm)	Approx. Pkd. Wt. (lbs.) (kg)	Cat. No. Stationary	Cat. No. Mobile*
30 762	29 <sup>3</sup> / <sub>4</sub> 749	35 <sup>1</sup> / <sub>2</sub> 902	39 <sup>1</sup> / <sub>2</sub> 1003	70 32	LT30XUS3	LTM30XUS3
30 762	35 <sup>3</sup> / <sub>4</sub> 908	35 <sup>1</sup> / <sub>2</sub> 902	39 <sup>1</sup> / <sub>2</sub> 1003	75 34	LT36XUS3	LTM36XUS3
30 762	47 <sup>3</sup> / <sub>4</sub> 1213	35 <sup>1</sup> / <sub>2</sub> 902	39 <sup>1</sup> / <sub>2</sub> 1003	95 43	LT48XUS3	LTM48XUS3
30 762	59 <sup>3</sup> / <sub>4</sub> 1517	35 <sup>1</sup> / <sub>2</sub> 902	39 <sup>1</sup> / <sub>2</sub> 1003	110 50	LT60XUS3	LTM60XUS3

\*Casters ordered separately. Refer to chart on next page for caster options.

Note: Worktables are load rated at 50 lbs. (23kg) per square foot up to a maximum of 600 lbs. (273kg), assuming load evenly distributed.

Note: LTM models are caster-ready for mobile applications. Casters sold separately. See chart on next page.

Phenolic resin: Compression molded of organic fiber-reinforced phenolic core with an integrally cured thermoset resin surface.

Worktables — Phenolic Top and Polymer Shelf

Width (in.) (mm)	Length (in.) (mm)	Work Surface Height (in.) (mm)	Overall Height (in.) (mm)	Approx. Pkd. Wt. (lbs.) (kg)	Cat. No. Stationary	Cat. No. Mobile*
30 762	29 <sup>3</sup> / <sub>4</sub> 749	36 <sup>1</sup> / <sub>2</sub> 927	40 <sup>1</sup> / <sub>2</sub> 1016	85 38	LT30XPG3	LTM30XPG3
30 762	35 <sup>3</sup> / <sub>4</sub> 908	36 <sup>1</sup> / <sub>2</sub> 927	40 <sup>1</sup> / <sub>2</sub> 1016	91 41	LT36XPG3	LTM36XPG3
30 762	47 <sup>3</sup> / <sub>4</sub> 1213	36 <sup>1</sup> / <sub>2</sub> 927	40 <sup>1</sup> / <sub>2</sub> 1016	118 53	LT48XPG3	LTM48XPG3
30 762	59 <sup>3</sup> / <sub>4</sub> 1517	36 <sup>1</sup> / <sub>2</sub> 927	40 <sup>1</sup> / <sub>2</sub> 1016	138 62	LT60XPG3	LTM60XPG3

\*Casters ordered separately. Refer to chart on next page for caster options.

Note: Worktables are load rated at 50 lbs. (23kg) per square foot up to a maximum of 600 lbs. (273kg), assuming load evenly distributed.

Worktables with Gray Phenolic Top and 3-Sided Frame

Width (in.) (mm)	Length (in.) (mm)	Work Surface Height (in.) (mm)	Overall Height (in.) (mm)	Approx. Pkd. Wt. (lbs.) (kg)	Cat. No. Stationary	Cat. No. Mobile*
30 762	29 <sup>3</sup> / <sub>4</sub> 749	36 <sup>1</sup> / <sub>2</sub> 927	40 <sup>1</sup> / <sub>2</sub> 1016	90 41	LT30XUPG3	LTM30XUPG3
30 762	35 <sup>3</sup> / <sub>4</sub> 908	36 <sup>1</sup> / <sub>2</sub> 927	40 <sup>1</sup> / <sub>2</sub> 1016	97 44	LT36XUPG3	LTM36XUPG3
30 762	47 <sup>3</sup> / <sub>4</sub> 1213	36 <sup>1</sup> / <sub>2</sub> 927	40 <sup>1</sup> / <sub>2</sub> 1016	125 56	LT48XUPG3	LTM48XUPG3
30 762	59 <sup>3</sup> / <sub>4</sub> 1517	36 <sup>1</sup> / <sub>2</sub> 927	40 <sup>1</sup> / <sub>2</sub> 1016	145 66	LT60XUPG3	LTM60XUPG3

\*Casters ordered separately. Refer to chart on next page for caster options.

Note: Worktables are load rated at 50 lbs. (23kg) per square foot up to a maximum of 600 lbs. (273kg), assuming load evenly distributed.



5MDXA



5MPX



5PCBX



5PCBXM



5MPXGSA

See page 16 for pricing.

For Mobile Worktables, Select Appropriate Casters from Chart Below. (Four brake casters are recommended for maximum table stability)  
Caster Selection Guide

*Caster Series	Wheel Material	Rollability	Floor Protection	Noise	Load Rating (lbs./kg)		Corrosion Resistance	Cart Washable	Antimicrobial Additive in Wheel
5MDXA/5MDBXA (brake)	High Modulus Rubber	Good	Good	Low	250	114	Low	No	No
5MPX/5MPBX (brake)	Polyurethane	Good	Good	Moderate	300	137	Low	No	No
5PCX/5PCBX (brake)	Polyurethane	Good	Good	Moderate	300	137	High	No	No
5PCXM/5PCBXM (brake)	Polyurethane	Good	Good	Moderate	300	137	High	No	Yes
5MPXGSA/5MPBXGSA (brake)	Polyurethane	Good	Good	Moderate	300	137	High	Yes	No

\*Casters listed are for use with MetroMax product solutions.  
NOTE: The total weight of the equipment and its load should not exceed three times the load rating per caster.  
Additional stem casters, in various sizes and wheel materials, are available. Contact your Metro rep for more information.

## MetroMax i Worktable Accessories — 52.01

### Backsplash

4" (102mm) high. Attaches to phenolic table top (page 236), using pre-drilled holes. Match length and color with selected countertop.

Length (in.)	Length (mm)	Approx. Pkd. Wt. (lbs.)	Approx. Pkd. Wt. (kg)	Cat. No. Black	Cat. No. Gray
27 <sup>3</sup> / <sub>4</sub>	705	5.5	2.5	LT30BSB	LT30BSG
33 <sup>3</sup> / <sub>4</sub>	875	6.5	2.9	LT36BSB	LT36BSG
45 <sup>3</sup> / <sub>4</sub>	1162	7.5	3.4	LT48BSB	LT48BSG
57 <sup>3</sup> / <sub>4</sub>	1466	9.5	4.3	LT60BSB	LT60BSG

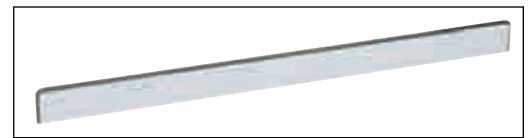

L30BSG



Keyboard Tray

### Keyboard Tray

Fits 48" and 60" (1219 and 1524mm) table lengths.

Cat. No. **LTKB**

Note: Keyboard tray and drawer will both fit a 60" (1524mm) table.

### Drawers

Fits 30", 36", 48" and 60" (760, 914, 1219 and 1525mm) table lengths.

(in.)	(mm)	Cat. No.
3	76	LTD3
6	152	LTD6
3	76	LTD3L
6	152	LTD6L

Note: Keyboard tray and drawer will both fit a 60" (1524mm) table.



Drawer

### Wire Shelf

Stainless or Epoxy-coated shelves available.

Length (in.)	Length (mm)	Approx. Pkd. Wt. (lbs.)	Approx. Pkd. Wt. (kg)	Cat. No. Stainless	Cat. No. Epoxy Coated
22 <sup>3</sup> / <sub>8</sub>	568	6	2.7	LT30WS	LT30WE
28 <sup>3</sup> / <sub>8</sub>	720	7.5	3.4	LT36WS	LT36WE
40 <sup>3</sup> / <sub>8</sub>	1025	10	4.5	LT48WS	LT48WE
52 <sup>3</sup> / <sub>8</sub>	1330	12	5.4	LT60WS	LT60WE

Note: Shelves are load rated for a maximum of 150 lbs. (68kg).



LT30WS

### Surface Mount Swing Arm for Flat Monitor

Cat. No. **LTFMA**

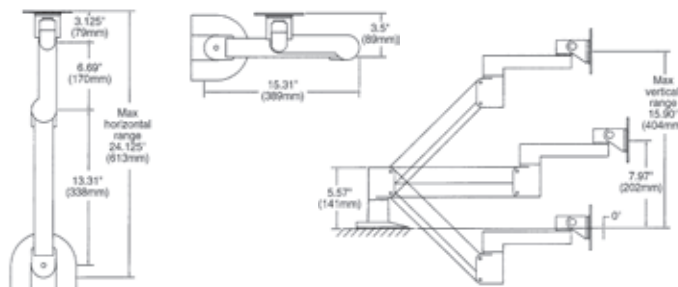

LTFMA

## Standard Terms and Conditions of Sale

### 1. Prices:

Unless otherwise specified in writing by Seller, Seller's price for the goods shall remain in effect for thirty (30) days after the date of Seller's quotation or acknowledgment of Buyer's order for the Goods, whichever occurs first, provided an unconditional, complete authorization for the immediate shipment of the Goods is received and accepted by Seller within such time period. If such authorization is not received by Seller within such thirty (30) day period, Seller shall have the right to change the price for the Goods to Seller's price for the Goods at the time of shipment.

### 2. Taxes:

Any current or future tax or governmental charge (or increase in same) affecting Seller's costs of production, sale, or delivery or shipment, or which Seller is otherwise required to pay or collect in connection with the sale, purchase, delivery, storage, processing, use or consumption of Goods, shall be for Buyer's account and shall be added to the price or billed to Buyer separately, at Seller's election.

### 3. Terms of Payment:

Subject to the approval of Seller's Credit Department, terms are 1% ten (10) days net thirty (30) days from date of Seller's invoice in U.S. currency. Freight and handling charges are not subject to discount. If any payment owed to Seller is not paid when due, it shall bear interest at a rate to be determined by Seller, which shall not exceed the maximum rate permitted by law, from the date on which it is due until it is paid. Should Buyer's financial responsibility become unsatisfactory to Seller, cash payments or security satisfactory to Seller may be required by Seller for future deliveries and for the Goods theretofore delivered. If such cash payment or security is not provided, in addition to Seller's other rights and remedies, Seller may discontinue deliveries. Seller shall have the right among other remedies, either to terminate the Agreement or to suspend further performance under this and/or other agreements with Buyer in the event Buyer fails to make any payment when due, which other agreements Buyer and Seller hereby amend accordingly. Buyer shall be liable for all expenses, including attorneys' fees, relating to the collection of past due amounts.

### Minimum Order:

Orders under Seller's Minimum Order Net will be charged a then-current Freight and Handling Fee or a then-current Handling Fee plus actual freight costs when applicable. See [www.metro.com/Terms](http://www.metro.com/Terms) for Seller's current Minimum Order value and associated Fees.

### Returns of Non-Defective Goods:

Written approval from Seller's customer service is required to return merchandise. All merchandise must be returned within 45 days from the invoice date and be returned in original, unopened, and resalable packaging.

Returns must meet Seller's then-current Minimum Return value and may be subject to a then-current restock charge. See [www.metro.com/Terms](http://www.metro.com/Terms) for Metro's current Minimum Return value and restock charge.

Exceptions — Special orders of cut posts, made to order dollies, cart covers, Designer Color product, Configured Products, and custom or made-to-order Goods are not returnable (See Section 17).

### 4. Shipment and Delivery:

While Seller will use all reasonable commercial efforts to maintain the delivery date(s) acknowledged or quoted by Seller, all shipping dates are approximate and not guaranteed. Seller reserves the right to make partial shipments and to segregate Configured Products and other made-to-order Goods from normal stock Goods. Seller, at its option, shall not be bound to tender delivery of any Goods for which Buyer has not provided shipping instructions and other required information. If the shipment of the Goods is postponed or delayed by Buyer for any reason, Buyer agrees to reimburse Seller for any and all storage costs and other additional expenses resulting therefrom. Risk of loss and legal title to the Goods shall transfer to Buyer for sales in which the end destination of the Goods is outside of the United States immediately after the Goods have passed beyond the territorial limits of the United States. For all other shipments, risk of loss for damage and responsibility shall pass from Seller to Buyer upon delivery to and receipt by carrier at Seller's shipping point. All shipments are F.O.B. Seller's shipping point. Any claims for shortages or damages suffered in transit are the responsibility of Buyer and shall be submitted by Buyer directly to the carrier. Shortages or damages must be identified and signed for at the time of delivery. Order consolidation may be available for an additional charge and Buyer may contact Seller's customer service for more information.

### 5. Limited Warranty:

Subject to the limitations of Section 6, Seller warrants that the Software will execute the programming instructions provided by Seller and that the Goods will be free from defects in material and workmanship under normal use, service and maintenance for a period of one (1) year from the date of shipment of the Goods by Seller, unless otherwise specified by Seller in writing. Seller does not warrant that the operation of the Software shall be uninterrupted or error free. THE WARRANTIES SET FORTH IN THIS SECTION 5 AND THE WARRANTY SET FORTH IN SECTION 7, ARE THE SOLE AND EXCLUSIVE WARRANTIES GIVEN BY SELLER WITH RESPECT TO THE GOODS AND ARE IN LIEU OF AND EXCLUDE ALL OTHER WARRANTIES, EXPRESS OR IMPLIED, ARISING BY OPERATION OF LAW OR OTHERWISE, INCLUDING WITHOUT LIMITATION, MERCHANTABILITY OR FITNESS FOR A PARTICULAR PURPOSE WHETHER OR NOT THE PURPOSE OR USE HAS BEEN DISCLOSED TO SELLER IN SPECIFICATIONS, DRAWINGS OR OTHERWISE, AND WHETHER OR NOT SELLER'S PRODUCTS ARE SPECIFICALLY DESIGNED AND/OR MANUFACTURED BY SELLER FOR BUYER'S USE OR PURPOSE.

These warranties do not extend to any losses or damages due to misuse, accident, abuse, neglect, normal wear and tear, negligence (other than Seller's), unauthorized modification or alteration, use beyond rated capacity, or improper

installation, maintenance or application. To the extent that Buyer or its agents has supplied specifications, information, representation of operating conditions or other data to Seller in the selection or design of the Goods and the preparation of Seller's quotation, and in the event that actual operating conditions or other conditions differ from those represented by Buyer, warranties or other provisions contained herein which are affected by such conditions shall be null and void.

If within thirty (30) days after Buyer's discovery of any warranty defects within the warranty period, Buyer notifies Seller thereof in writing, Seller shall, at its option, and as Buyer's exclusive remedy, repair, correct or replace F.O.B. point of manufacture, or refund the purchase price for, that portion of the goods found by Seller to be defective.

Failure by Buyer to give such written notice within the applicable time period shall be deemed an absolute and unconditional waiver of Buyer's claim for such defects. All costs of dismantling, reinstallation and freight and the time and expense of Seller's personnel and representatives for site travel and diagnosis under these warranties shall be borne by Buyer unless accepted in writing by Seller. Goods repaired or replaced during the warranty period shall be covered by the foregoing warranty warranties for the remainder of the original warranty period or ninety (90) days from the date of shipment, whichever is longer.

Buyer assumes all other responsibility for any loss, damage, or injury to persons or property arising out of, connected with, or resulting from the use of Goods, either alone or in combination with other products/components.

Section 5 applies to any entity or person who may buy, acquire or use the Goods, including any entity or person who obtains the Goods from Buyer, and shall be bound by the limitations therein, including Section 6. Buyer agrees to provide such subsequent transferee conspicuous, written notice of the provisions of Sections 5 and 6.

Buyer assumes all other responsibility for any loss, damage, or injury to persons or property arising out of, connected with, or resulting from the use of Goods, either alone or in combination with other products/components.

In addition to the above standard warranty, Seller offers a MetroESP Parts-Only Extended Warranty Option, a MetroESP Parts & Labor Extended Warranty Option and MetroESP Preventive Maintenance Option. To learn more about the terms of these options, see Seller's website at [www.metro.com/terms](http://www.metro.com/terms). If Buyer elects to purchase a MetroESP Option, Buyer will be bound to the terms and conditions, which are contained on such website address, at the time of Buyer's order submission. Seller reserves the right to change the terms of such MetroESP Options at any time in its discretion; provided, that the terms in effect at the time of Buyer's order shall remain the terms applicable to such order.

**6. Limitation of Remedy and Liability:**

THE SOLE AND EXCLUSIVE REMEDY FOR BREACH OF ANY WARRANTY HEREUNDER (OTHER THAN THE WARRANTY PROVIDED UNDER SECTION 7) SHALL BE LIMITED TO REPAIR, CORRECTION OR REPLACEMENT, OR REFUND OF THE PURCHASE PRICE UNDER SECTION 5.

SELLER SHALL NOT BE LIABLE FOR DAMAGES CAUSED BY DELAY IN PERFORMANCE AND THE REMEDIES OF BUYER SET FORTH IN THIS AGREEMENT ARE EXCLUSIVE. IN NO EVENT, REGARDLESS OF THE FORM OF THE CLAIM OR CAUSE OF ACTION (WHETHER BASED IN CONTRACT, INFRINGEMENT, NEGLIGENCE, STRICT LIABILITY, OTHER TORT OR OTHERWISE), SHALL SELLER'S LIABILITY TO BUYER AND/OR ITS CUSTOMERS EXCEED THE PRICE PAID BY BUYER FOR THE SPECIFIC GOODS PROVIDED BY SELLER GIVING RISE TO THE CLAIM OR CAUSE OF ACTION. BUYER AGREES THAT IN NO EVENT SHALL SELLER'S LIABILITY TO BUYER AND/OR ITS CUSTOMERS EXTEND TO INCLUDE INCIDENTAL, CONSEQUENTIAL OR PUNITIVE DAMAGES. The term "consequential damages" shall include, but not be limited to, loss of anticipated profits, business interruption, loss of use, revenue, reputation and data, costs incurred, including without limitation, for capital, fuel, power and loss or damage to property or equipment.

It is expressly understood that any technical advice furnished by Seller with respect to the use of the Goods is given without charge, and Seller assumes no obligation or liability for the advice given, or results obtained, all such advice being given and accepted at Buyer's risk.

**7. Patents and Copyrights:**

Subject to the limitations of the second paragraph of Section 6, Seller warrants that the Goods sold, except as are made specifically for Buyer according to Buyer's specifications, do not infringe any valid U.S. patent or copyright in existence as of the date of shipment. This warranty is given upon the condition that Buyer promptly notify Seller of any claim or suit involving Buyer in which such infringement is alleged and cooperate fully with Seller and permit Seller to control completely the defense, settlement or compromise of any such allegation of infringement. Seller's warranty as to use patents only applies to infringement arising solely out of the inherent operation according to Seller's specifications and instructions (i) of such Goods, or (ii) of any combination of Goods acquired from Seller in a system designed by Seller. In the event such Goods are held to infringe such a U.S. patent or copyright in such suit, and the use of such Goods is enjoined, or in the case of a compromise or settlement by Seller, Seller shall have the right, at its option and expense, to procure for Buyer the right to continue using such Goods, or replace them with non-infringing Goods, or modify same to become non-infringing, or grant Buyer a credit for the depreciated value of such Goods and accept return of them. In the event of the foregoing, Seller may also, at its option, cancel the agreement as to future deliveries of such Goods, without liability.

**8. Excuse of Performance:**

Seller shall not be liable for delays in performance or for non-performance due to the following (none of which is as a result of Seller's negligent or intentional conduct): acts of God, acts of Buyer, war, riot, fire, flood, power surges, other severe weather, sabotage, or epidemics; strikes or labor disturbances; governmental requests, restrictions, laws, regulations, orders or actions; unavailability of or delays in transportation; default of suppliers; or unforeseen circumstances or any events or causes beyond Seller's reasonable control. If Seller determines that its ability to supply the total demand for the Goods is made impracticable due to causes addressed in this Section 8, Seller may allocate its available supply of the Goods or such material (without obligation to acquire other supplies of any such Goods or such materials) among itself and its purchasers on such basis as Seller determines to be equitable without liability for any failure of performance which may result therefrom. Deliveries suspended or not made by reason of this section may be canceled by Seller upon notice to Buyer without liability, but the balance of the agreement shall otherwise remain unaffected as a result of the foregoing.

If Seller determines that its ability to supply the total demand for the Goods, or to obtain material used directly or indirectly in the manufacture of the Goods, is hindered, limited or made impracticable due to causes set forth in the preceding paragraph, Seller may allocate its available supply of the Goods or such material (without obligation to acquire other supplies of any such Goods or material) among its purchasers on such basis as Seller determines to be equitable without liability for any failure of performance which may result therefrom.

**9. Cancellation:**

The Buyer may cancel orders only upon written notice and upon payment to Seller of cancellation or restocking charges which include, among other things, all costs and expenses incurred and commitments made by the Seller and a reasonable profit thereon. Large requirements of made-to-order products may require a non-cancelable purchase order. Provided, however, Buyer shall incur no costs for canceling orders in which seller has not timely delivered. Once ordered, MetroESP options may not be cancelled, and are not refundable, in whole or part.

**10. Changes:**

Buyer may request changes or additions to the Goods consistent with Seller's specifications and criteria. In the event such changes or additions are accepted by Seller, Seller may revise the price and delivery schedule.

Seller reserves the right to change designs and specifications for the Goods without prior notice to Buyer, except with respect to Goods being made-to-order for Buyer.

**11. Tooling:**

Tool, die, and pattern charges, if any, are in addition to the price of the Goods and are due and payable upon completion of the tooling. All such tools, dies and patterns shall be and remain the property of Seller. Charges for tools, dies, and patterns do not convey to Buyer, title, ownership interests in, or rights to possession

or removal, nor prevent their use by Seller for other purchasers, except as otherwise expressly provided by Seller and Buyer in writing with reference to this provision.

**12. Assignment:**

Buyer shall not assign its rights or delegate its duties hereunder or any interest therein or any rights hereunder without the prior written consent of the Seller, and any such assignment, without such consent, shall be void.

**13. Software:**

Notwithstanding any other provision herein to the contrary, Seller or applicable third party licensor to Seller shall retain all rights of ownership and title in its respective Software, including without limitation all rights of ownership and title in its respective copies of such Software. Except as otherwise provided herein, Buyer is hereby granted a nonexclusive, non-transferable royalty free license to use the Software incorporated into the Goods solely for purposes of Buyer properly utilizing such Goods purchased from Seller. All other Software shall be furnished to, and used by, Buyer only after execution of Seller's (or the licensor's) applicable standard license agreement.

**14. General Provisions:**

These terms and conditions supersede all other communications, negotiations and prior oral or written statements regarding the subject matter of these terms and conditions. No change, modification, rescission, discharge, abandonment or waiver of these terms and conditions shall be binding upon the Seller unless made in writing and signed on its behalf by a duly authorized representative of Seller. No conditions, usage of trade, course of dealing or performance, understanding or agreement purporting to modify, vary, explain, or supplement these terms and conditions shall be binding unless hereafter made in writing and signed by the party to be bound, and no modification or additional terms shall be applicable to this agreement by Seller's receipt, acknowledgment, or acceptance of purchase orders, shipping instruction forms, or other documentation containing terms at variance with or in addition to those set forth herein. Any such modifications or additional terms are specifically rejected by Seller. No waiver by either party with respect to any breach or default or of any right or remedy, and no course of dealing, shall be deemed to constitute a continuing waiver of any other breach or default or of any other right or remedy, unless such waiver be expressed in writing and signed by the party to be bound. All typographical or clerical errors made by Seller in any quotation, acknowledgment or publication are subject to correction.

The validity, performance, and all other matters relating to the interpretation and effect of this agreement shall be governed by the law of the State of Missouri without regard to its conflict of laws principles. Buyer and Seller agree that the proper venue for all actions arising in connection herewith shall be only in Missouri and the parties agree to submit to such jurisdiction. No action, regardless of form, arising out of transactions relating to this contract, may be brought by either party more than two (2) years after the

### Standard Terms and Conditions of Sale

(continued)

cause of action has accrued. The Convention for the International Sales of Goods shall not apply to this agreement.

#### 15. Buyer's Compliance with Laws:

In connection with the transactions contemplated by this agreement, Buyer is familiar with and shall fully comply with all applicable laws, regulations, rules and other requirements of the United States and of any applicable state, foreign and local governmental body in connection with the purchase, receipt, use, shipment, transfer and disposal of the Goods.

#### 16. Export/Import:

Buyer agrees that all applicable import and export control laws, regulations, orders and requirements, including without limitation those of the United States and the European Union, and the jurisdictions in which the Seller and Buyer are established or from which Goods and Services may be supplied, will apply to their receipt and use. In no event shall Buyer use, transfer, release, import, export, Goods in violation of such applicable laws, regulations, orders or requirements.

#### 17. Additional Terms & Conditions Expressly Related to Configured Products\*:

The following Terms and Conditions provided expressly for Configured Products supersede those stated for all other Goods of Seller. Those situations not specifically addressed by the following Configured Products Terms and Conditions are governed by Seller's standard Terms and Conditions of Sale as provided above.

##### A. Configured Products — Order Change/Cancellation Policy:

All order change requests must be requested through Seller's customer service. Changes/cancellations requested within 7 workdays of the scheduled ship date that will impact order production, will incur, a then-current minimum Change/Cancellation Fee, up to the full order value, depending on the percentage of the order completed. See [www.metro.com/terms](http://www.metro.com/terms) for Metro's Configured Products minimum order Change/Cancellation Fee. Customer service will relay percentage of order completed along with the Change/Cancellation Fee amount. Prior to Seller accepting the change, a revised purchase order (including associated Fee) is required. Orders for C5 cabinets with an "A" suffix are non-cancellable and non-returnable.

##### B. Configured Products — Return Policy

— Accessories are returnable at the sole discretion of Seller.

- A Return Merchandise Authorization (RMA) must be obtained through Seller's customer service prior to returning the product.
- All returns will be coordinated by Seller's customer service and return freight costs will be charged back.
- All returns must be in original packaging, unused and in saleable condition.
- All returns must be made within 45 days of invoice date.

Returns must meet Metro's then-current Minimum Return Value and may be subject to a then-current restock charge. See [www.metro.com/Terms](http://www.metro.com/Terms) for Metro's current Minimum Return Value and Configured Product Restock Charge.

---

*\*Configured Products apply to thermal holding and transport cabinets, healthcare carts, point-of-care workstations, automated dispensing products, modular work centers, countertops, fixtures and medication carts.*

---



Most Metro Foodservice Products are listed by National Sanitation Foundation. For specific items, please check the latest NSF foodservice listing.

PRODUCT	PAGE	PRODUCT	PAGE	PRODUCT	PAGE	PRODUCT	PAGE
<b>Cabinets</b>		<b>Cassettes, Storage.....</b>	<b>150</b>	Designer.....	43	Wire Management Clip .....	64
Automated Dispensing ..	120-127	<b>Casters</b>		Dunnage Platforms .....	101-102	<b>Starsys System, Enclosed</b>	
Catheter.....	171	Caster Guide .....	51	Erecta Shelf .....	69	<b>Accessories .....</b>	<b>146-150, 156-158</b>
Lionville Fixtures.....	132-137	Antimicrobial .....	50	HD Super Solid .....	70-71	Cabinets, Mobile,	
MedDispense .....	120-127	Decorative .....	51	Hi-Rise.....	100	Stationary .....	151-159
Pharmacy Fixtures.....	132-137	Plate .....	53	MetroMax iQ.....	22-28	Carts .....	141-152
Scope Storage.....	172	Polymer.....	16, 50	Seismic.....	108-109	Cassettes.....	150
Starsys Supply .....	151-159	Stainless Steel .....	16, 50	Starter and		Catheter.....	171
Suture .....	156, 170, 216	Stem .....	16, 50	Add-On Units .....	44-45	Doors .....	159
Wall.....	131, 167-169	<b>Computer Accessories.....</b>	<b>64</b>	MetroMax i Polymer .....	20	Drawers.....	147, 157, 159
<b>Carts</b>		<b>Counter Units.....</b>	<b>67</b>	MetroMax Q Polymer		I.V. Storage, Secure .....	170
Anesthesia .....	142, 184, 189, 196, 205	<b>HD qwikTRAK .....</b>	<b>92-95</b>	Wire Hybrid .....	21	Preconfigured Units .....	142-143, 145, 152-155, 161-165, 169-172
Basix Procedure/ Treatment .....	194-211	<b>High-Density Storage .....</b>	<b>92-100</b>	Super Adjustable		Scope System.....	172
Basket .....	87	<b>Information Technology</b>		Super Erecta .....	36-39	Suture .....	170
Case, Surgical.....	212-213	Automated Dispensing		Super Erecta Pro Wire		Wall Cabinets.....	167-169
Catheter.....	171, 217	Cabinets.....	120-127	Polymer Hybrid.....	32-35	WorkCenters, Mobile,	
Code Response .....	178-180, 184, 196-197, 205	Computerized Procedure		Super Erecta Shelf — Solid ..	66-68	Stationary .....	160-166
Code Response,		Carts .....	187-189, 144-145	Super Erecta Shelf — Wire ..	40-64		
Pediatric.....	178, 184, 196, 206	Point-of-Care		Wall.....	74-82		
Computer .....	114-119, 142, 144-145, 188-189	Workstations .....	114-119	<b>Shelving Accessories</b>			
Endoscopic.....	185, 196, 205	Wall Mounts.....	115	Baskets.....	27, 47, 59, 60	<b>Tables, MetroMax i,</b>	
Exchange/Supply ...	222, 224, 228	<b>Posts</b>		Bins .....	62	<b>Polymer .....</b>	<b>236-237</b>
Flexline Procedure/ Treatment .....	182-193	Designer.....	43	Bumpers .....	51, 71	<b>Tables, Process,</b>	
I.V.....	142, 170, 185, 215, 225	HD Super.....	70	Clamps, Post,		<b>Stainless Steel .....</b>	<b>232-235</b>
Inhalation Therapy .....	215	MetroMax i.....	14	Shelf Joining .....	14, 47, 68		
Isolation .....	184, 196, 205	MetroMax Q.....	15	Color Identification Tubes .....	60	<b>Specialty Storage .....</b>	<b>215-218</b>
Lifeline Emergency.....	176-181	Super Erecta		Color Shelf Markers .....	25, 35		
Linen Supply.....	228-229	SiteSelect.....	35, 37, 42	Covers, Cart .....	63	<b>Top-Track High-Density</b>	
Lionville Medication .....	120-127	<b>Racks</b>		Covers, Dolly Dust.....	52	<b>Storage System .....</b>	<b>93, 96-100</b>
MetroTrux .....	229	Can.....	26	Dividers, Shelf ..	22, 23, 35, 55, 68		
Point-of-Care.....	114-119	Drying.....	28	Dollies .....	52	<b>Tote Box Carriers .....</b>	<b>218</b>
Security.....	103-107	Dunnage .....	101-102	Enclosure Panels .....	24, 56		
Slanted Shelf .....	49	Sterile Wrap .....	216	Foot Plates .....	14, 47, 71	<b>Trucks, Shelving</b>	
Starsys Procedure,		Tray Drying.....	28	Floor Glides .....	47	Bulk (Trux).....	229
Specialty, Supply .....	141-150	Wrap .....	216	Frames .....	27, 52, 57	Convertible Linen (Trux) .....	229
Stem Caster.....	18, 39, 48	<b>Security Trucks</b>		Handles.....	17, 54	Dolly.....	49
Storage and Transport ...	219-223	<b>and Units.....</b>	<b>103-107</b>	Hangers .....	57-60	Security.....	103-107
Suture .....	156, 170, 216	<b>Shelves</b>		Hooks.....	58	<b>Wall Cabinets</b>	
Tote Box .....	218	Basket .....	27, 47	Inlays, Shelf .....	58	Starsys.....	167-169
Utility		Cantilever.....	46	Keyboard Tray .....	64	Lionville Series.....	131
Accessories .....	50-64, 66-71	Dunnage .....	14, 46, 71	Label Holders .....	25, 35, 61	<b>Wall Shelving</b>	
Deep Ledge (Polymer) .....	86	Keyboard.....	64	Ledges, Shelf.....	22, 23, 55	Brackets .....	74-82
Heavy Duty (Polymer) .....	83	<b>Shelving</b>		Leveling Feet .....	47	Erecta Shelf .....	81
MetroMax iQ (Polymer) ....	19, 83	Convenience Pak.....	46	Power Strip.....	64	MetroMax i.....	80
myCart Series (Polymer)....	84-85			Rods and Tabs .....	57	SmartWall G3.....	74-79
Wire/Solid Standard Duty.....	88			S Hooks.....	20, 21, 35, 38, 44	Super Erecta Shelf .....	81-82
Workstation on				Shelf Markers .....	25, 35	<b>WorkCenters</b>	
Wheels.....	114-119			Slides, Tote Box .....	26, 59, 68	Lionville Fixtures.....	132-137
				Split Sleeves, Super Erecta .....	47	Starsys.....	162-166
				Tote Boxes.....	226-227	<b>Worktables .....</b>	<b>232-237</b>
				Tow Bar Assembly .....	54		
				Wedge Connector, Max iQ... 14, 15			

## Improving patient care. Together.™

U.S. CUSTOMER SERVICE  
Phone: 1.800.992.1776  
Fax (PA): 1.800.638.9263  
Fax: (CA): 1.800.638.3292

CANADA CUSTOMER SERVICE  
Phone: 1.905.676.9890  
Phone: 1.800.992.1776  
Fax: 1.905.676.9262

PRODUCT  
INFORMATION/LITERATURE  
(U.S. and Canada Only):  
U.S./Canadian Toll-Free  
Phone: 1.800.992.1776

DISTRIBUTION CENTERS  
California  
9393 Arrow Highway  
Cucamonga, CA 91730

Pennsylvania  
Thomas & Second Streets  
Wilkes-Barre, PA 18705

Tennessee  
3263 Elam Farms Parkway  
Murfreesboro, TN 37127

Canada  
Metropolitan Wire (Canada) LTD.  
3160 Orlando Drive  
Mississauga, Ontario  
Canada L4V 1R5

InterMetro European  
Distribution Center  
De Riemsdijk 1  
4004 LC Tiel  
The Netherlands

INTERNATIONAL SALES/  
CUSTOMER SERVICE OFFICES  
Asia/Pacific  
InterMetro Industries Corporation  
151 Lorong Chuan Lobby D #05-04  
New Tech Park, Singapore 556741  
Phone: +65 6350 1291  
Fax: +65 6285 1516

Middle East/Africa  
InterMetro Industries Corporation  
P.O. Box: 17034  
Jebel Ali Free Zone  
Dubai-United Arab Emirates  
Phone: +971 4 811 8286  
Fax: +971 4 886 5465

Europe  
InterMetro Industries B.V.  
Heerbaan 242  
4817 NL Breda  
Breda  
The Netherlands  
Phone: +31 76 587 7550  
Fax: +31 76 581 1313

Latin America  
Metro International Corporation  
Bugambillas 316  
Cond. Rancho Contento  
45010 Zapopan Jalisco  
Mexico  
Phone: +52 33 362 778 30  
Fax: +52 33 362 778 30

CORPORATE HEADQUARTERS  
651 North Washington Street  
Wilkes-Barre, PA 18705  
Phone: 1.570.825.2741  
Fax: 1.570.825.2852



LO4-030NP • Rev. 8/14

Information and specifications are subject to  
change without notice. Please confirm at time of order.

© 2014 InterMetro Industries Corporation, Wilkes-Barre, PA 18705  
The Emerson logo is a trademark and a service mark of Emerson Electric Company.

